



US010688274B1

(12) **United States Patent**
Jovanov

(10) **Patent No.:** **US 10,688,274 B1**
(45) **Date of Patent:** **Jun. 23, 2020**

(54) **SYSTEMS AND METHODS FOR MULTI-MODAL AND NON-INVASIVE STIMULATION OF THE NERVOUS SYSTEM**

(58) **Field of Classification Search**
None
See application file for complete search history.

(71) Applicant: **Emil Jovanov**, Huntsville, AL (US)

(56) **References Cited**

(72) Inventor: **Emil Jovanov**, Huntsville, AL (US)

U.S. PATENT DOCUMENTS

(73) Assignee: **Board of Trustees of the University of Alabama, for and on behalf of the University of Alabama in Huntsville**, Huntsville, AL (US)

3,497,637 A * 2/1970 Lawrence A61F 11/04
381/23.1
3,659,614 A * 5/1972 Jankelson A61N 1/321
607/139

(Continued)

(*) Notice: Subject to any disclaimer, the term of this patent is extended or adjusted under 35 U.S.C. 154(b) by 184 days.

OTHER PUBLICATIONS

(21) Appl. No.: **15/605,610**

Emily Waltz, "DARPA to Use Electrical Stimulation to Enhance Military Training," <http://spectrum.ieee.org/the-human-os/biomedical/devices/.WQnuUvGCyNU.gmail>, Apr. 26, 2017.

(22) Filed: **May 25, 2017**

Primary Examiner — Brian T Gedeon

Related U.S. Application Data

(74) *Attorney, Agent, or Firm* — Maynard Cooper & Gale, P.C.; Jon E. Holland

(60) Provisional application No. 62/342,096, filed on May 26, 2016.

(51) **Int. Cl.**
A61M 21/00 (2006.01)
A61N 1/04 (2006.01)

(57) **ABSTRACT**

(Continued)

Systems and methods are provided to combine multiple stimulation modalities to significantly increase the effectiveness of non-invasive stimulation. Multiple sensor and stimulation devices and modalities can be combined into a single, compact unit that minimizes the need for additional sensors or stimulation devices. The system features several subunits, referred to as sensory and stimulation devices (SSD), that are integrated into a headphone setup. The system is controlled by a centralized controller that communicates with all of the SSDs and with an external computer system that delivers learning material synchronized with the delivery of stimulations and the collection of user responses based on physiological signals.

(52) **U.S. Cl.**
CPC *A61M 21/00* (2013.01); *A61H 23/02* (2013.01); *A61N 1/0456* (2013.01); *A61N 1/36025* (2013.01); *A61N 2/002* (2013.01); *A61N 5/0618* (2013.01); *A61M 2021/0016* (2013.01); *A61M 2021/0022* (2013.01); *A61M 2021/0027* (2013.01); *A61M 2021/0044* (2013.01); *A61M 2021/0072* (2013.01); *A61M 2230/005* (2013.01); *A61M 2230/04* (2013.01); *A61M 2230/10* (2013.01); *A61M 2230/63* (2013.01); *A61M 2230/65* (2013.01); *A61N 2005/0626* (2013.01)

20 Claims, 6 Drawing Sheets

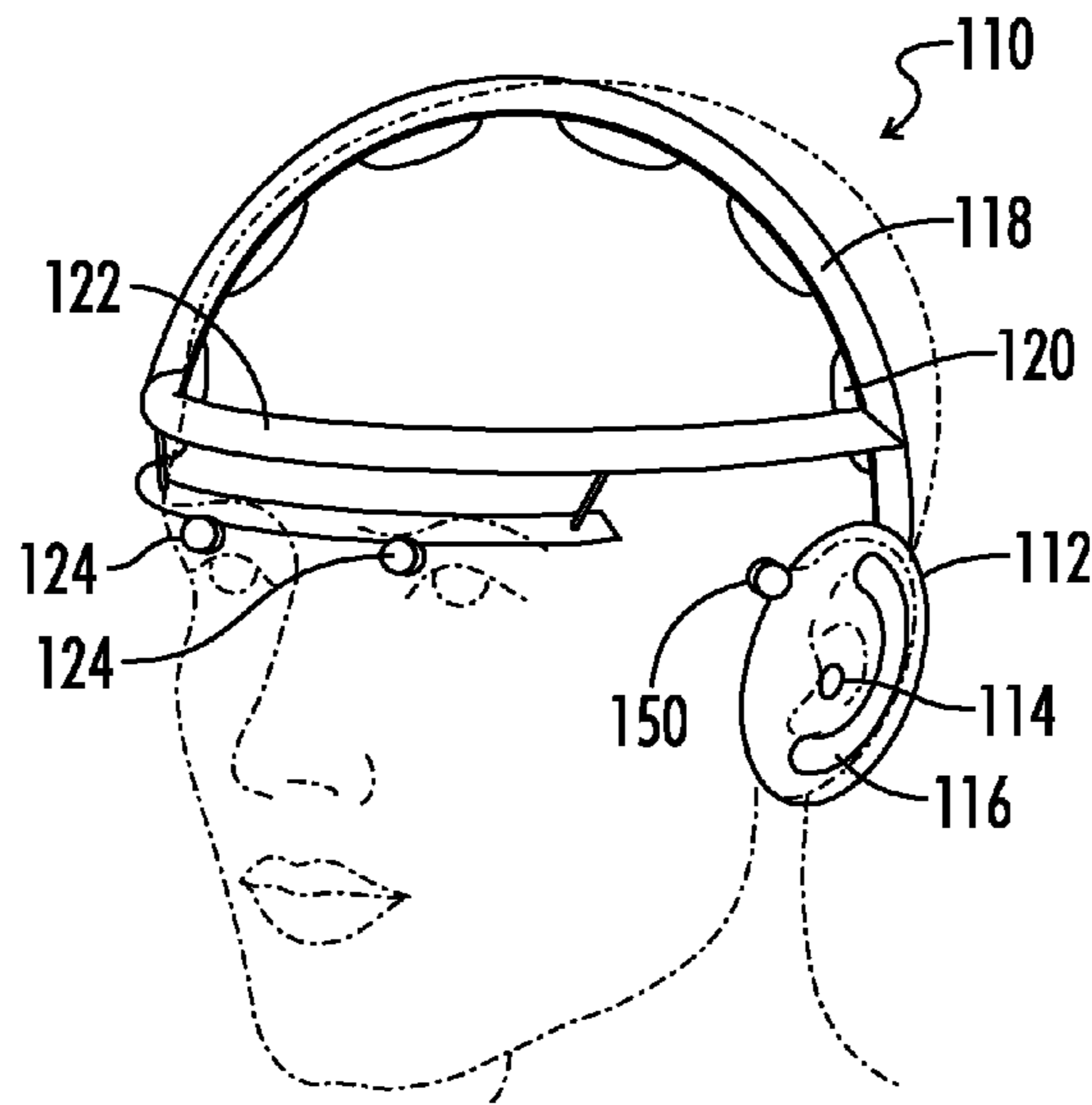

US 10,688,274 B1

(51)	Int. Cl. <i>A61N 5/06</i> (2006.01) <i>A61N 1/36</i> (2006.01) <i>A61N 2/00</i> (2006.01) <i>A61H 23/02</i> (2006.01)				8,972,024 B2 * 3/2015 Walker A61H 39/002 607/46 9,242,092 B2 1/2016 Simon et al. 9,248,286 B2 2/2016 Simon et al. 9,254,383 B2 2/2016 Simon et al. 9,579,060 B1 * 2/2017 Lisy A61B 5/6803 9,782,584 B2 * 10/2017 Cartledge A61N 1/36036 2005/0165460 A1 * 7/2005 Erfan A61N 1/326 607/57 2012/0197355 A1 * 8/2012 Braun A61M 21/00 607/72 2014/0316456 A1 * 10/2014 Ando A61H 7/004 606/204 2016/0015289 A1 * 1/2016 Simon A61B 5/04842 600/301 2016/0235352 A1 * 8/2016 DiLorenzo A61B 5/04001 2017/0165485 A1 * 6/2017 Sullivan A61N 1/36021 2018/0021564 A1 * 1/2018 Goodall A61N 2/002 600/379 2018/0040258 A1 * 2/2018 Kouache G01C 21/3652 2018/0256888 A1 * 9/2018 Wingeier A61N 1/0484
(56)	References Cited U.S. PATENT DOCUMENTS 4,638,807 A * 1/1987 Ryder A61B 5/04085 600/383 5,318,503 A * 6/1994 Lord A61M 21/00 600/27 5,514,175 A * 5/1996 Kim A61H 39/002 607/115 6,537,301 B1 * 3/2003 Kamei A61M 21/00 607/88 6,556,868 B2 4/2003 Naritoku et al. 8,639,343 B2 * 1/2014 De Vos A61N 1/3601 600/529 8,914,116 B2 * 12/2014 De Vos A61H 39/002 607/135				

* cited by examiner

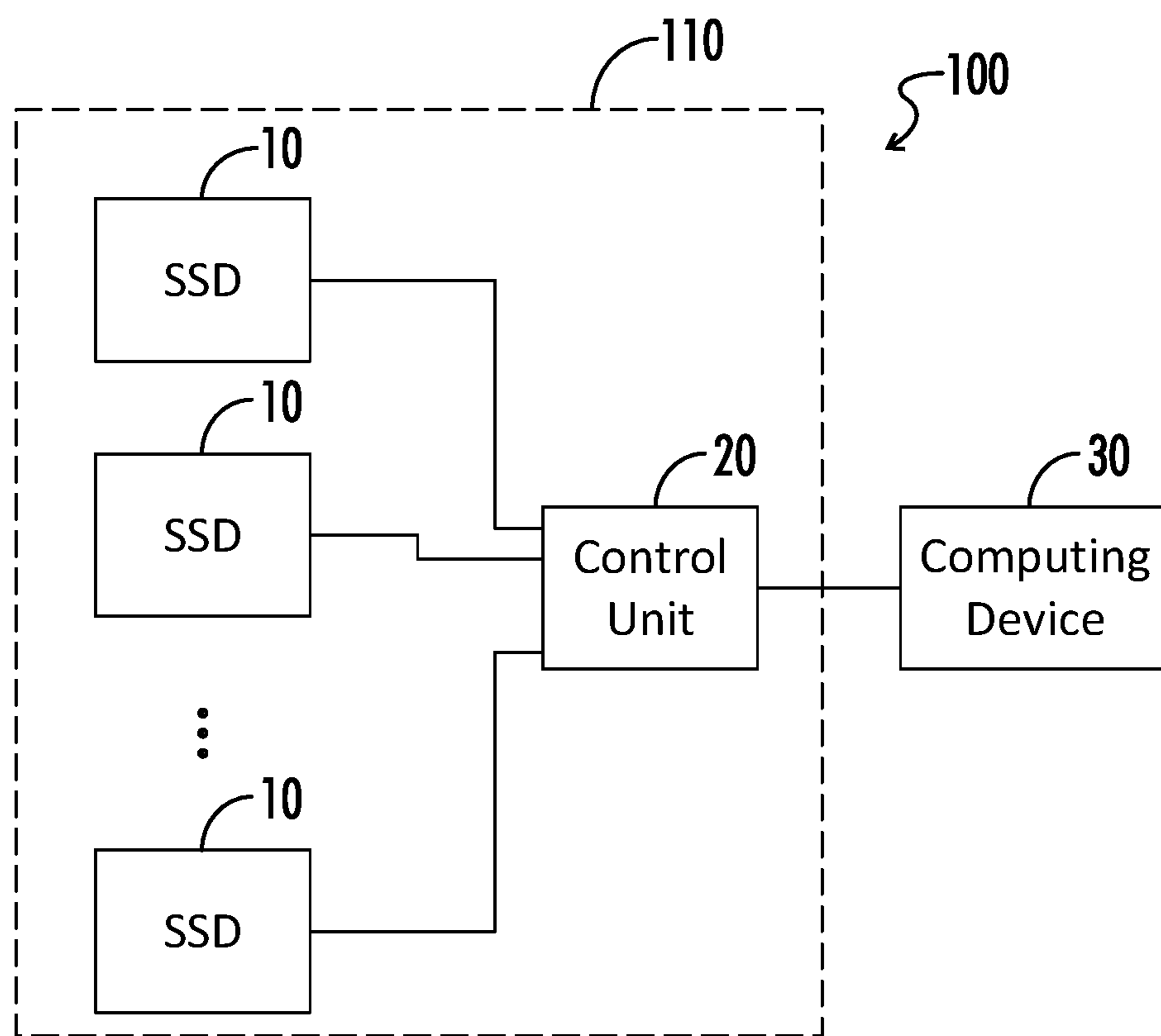

FIG. 1

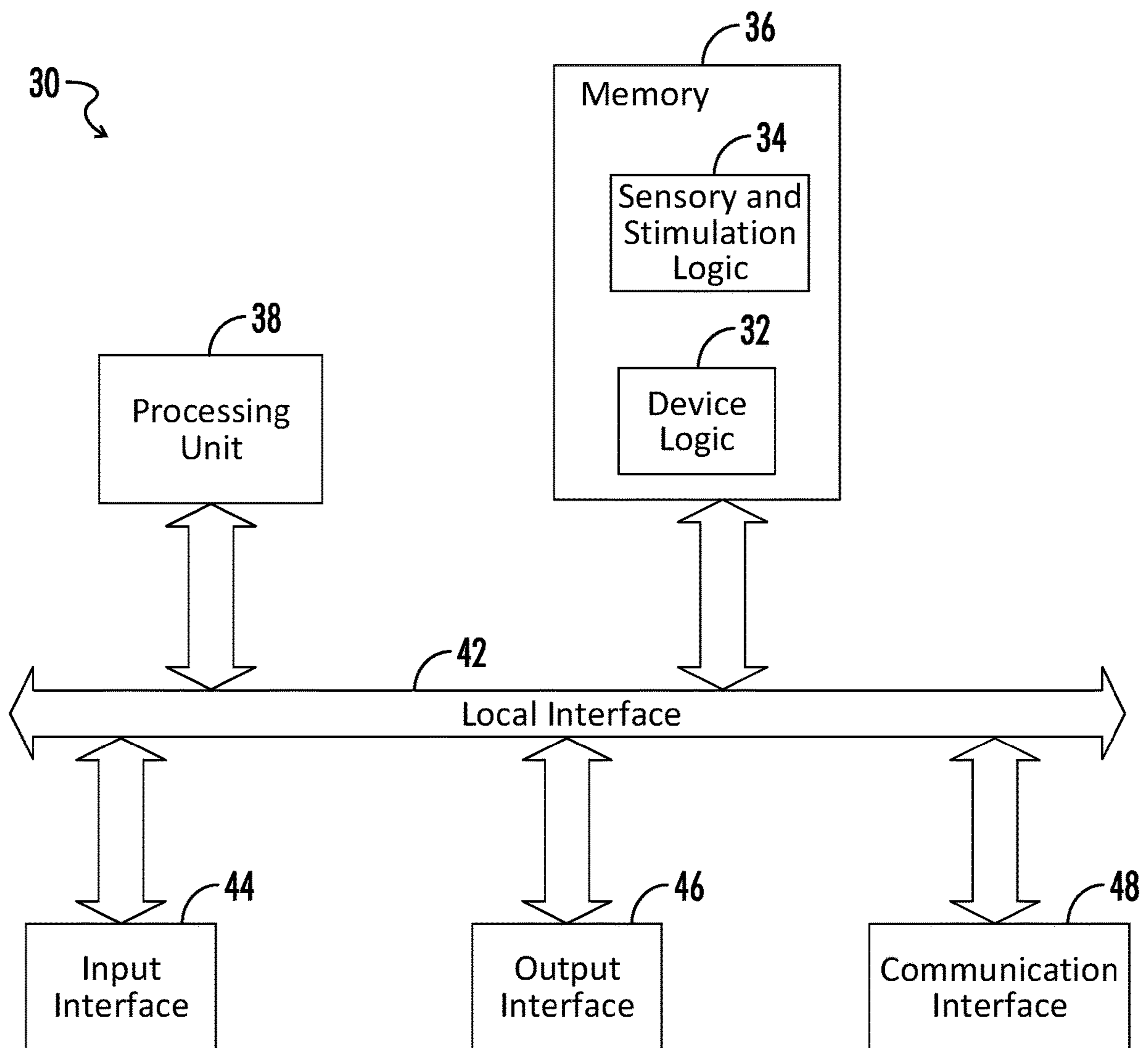

FIG. 2

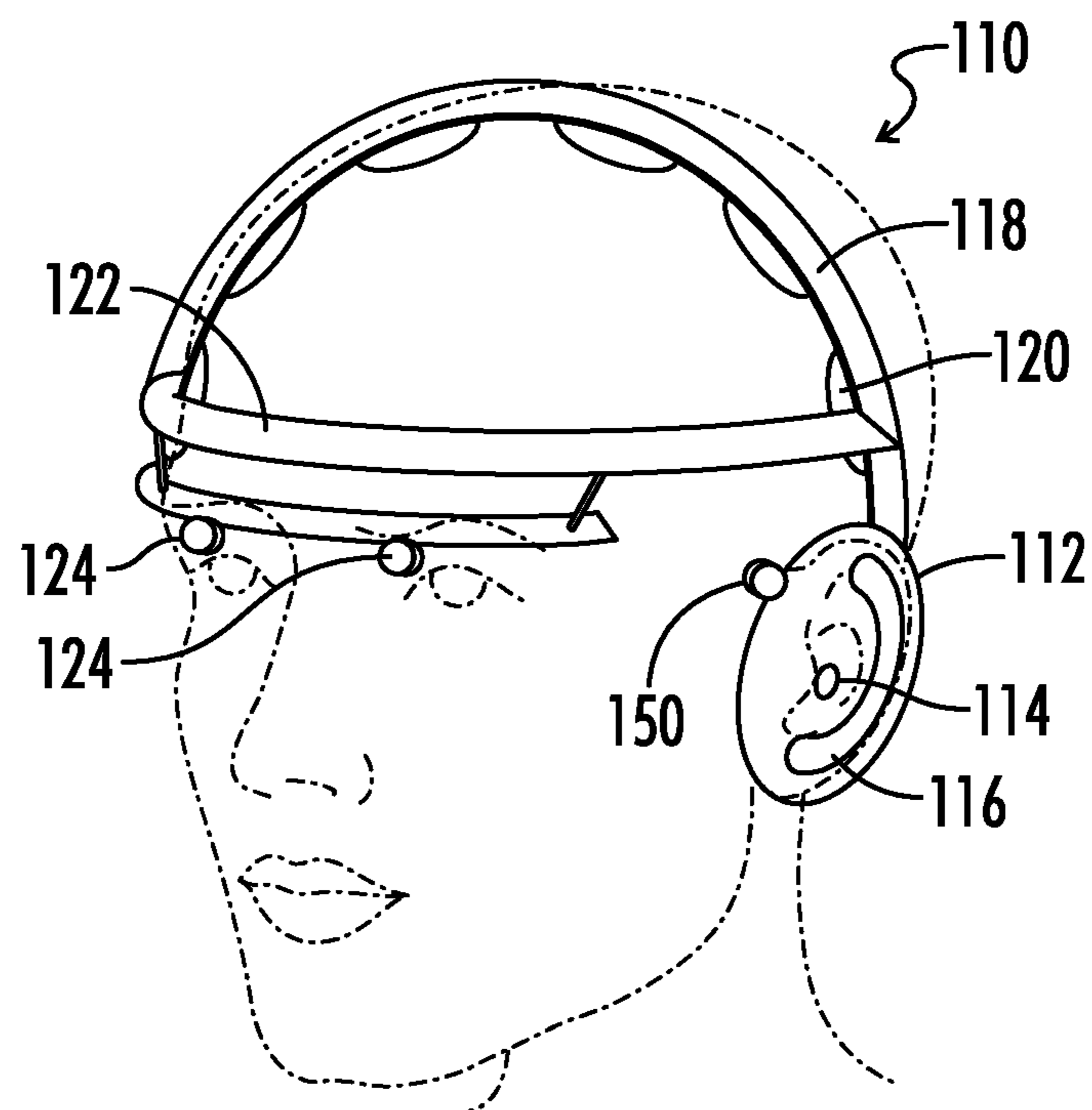

FIG. 3

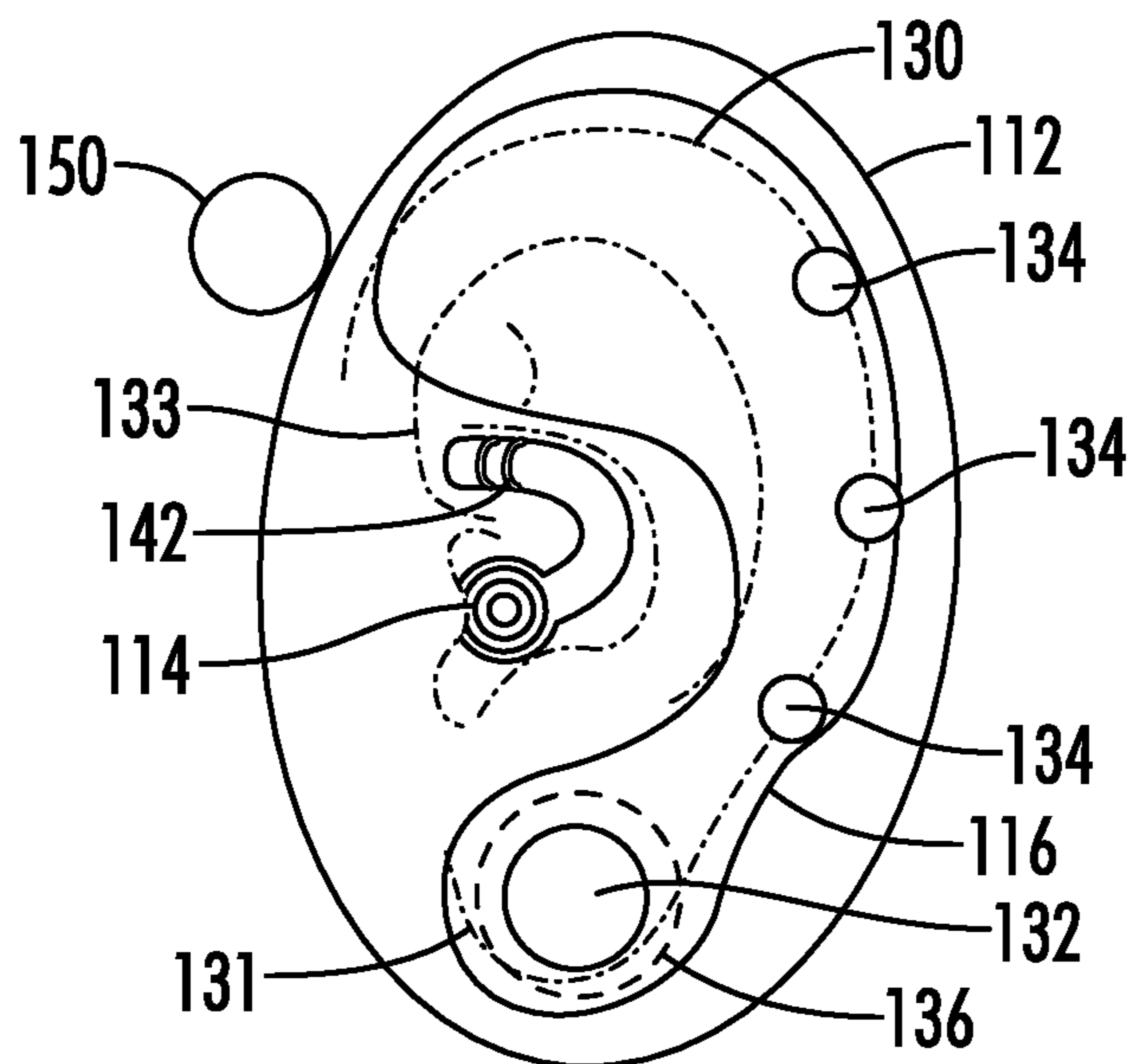

FIG. 4

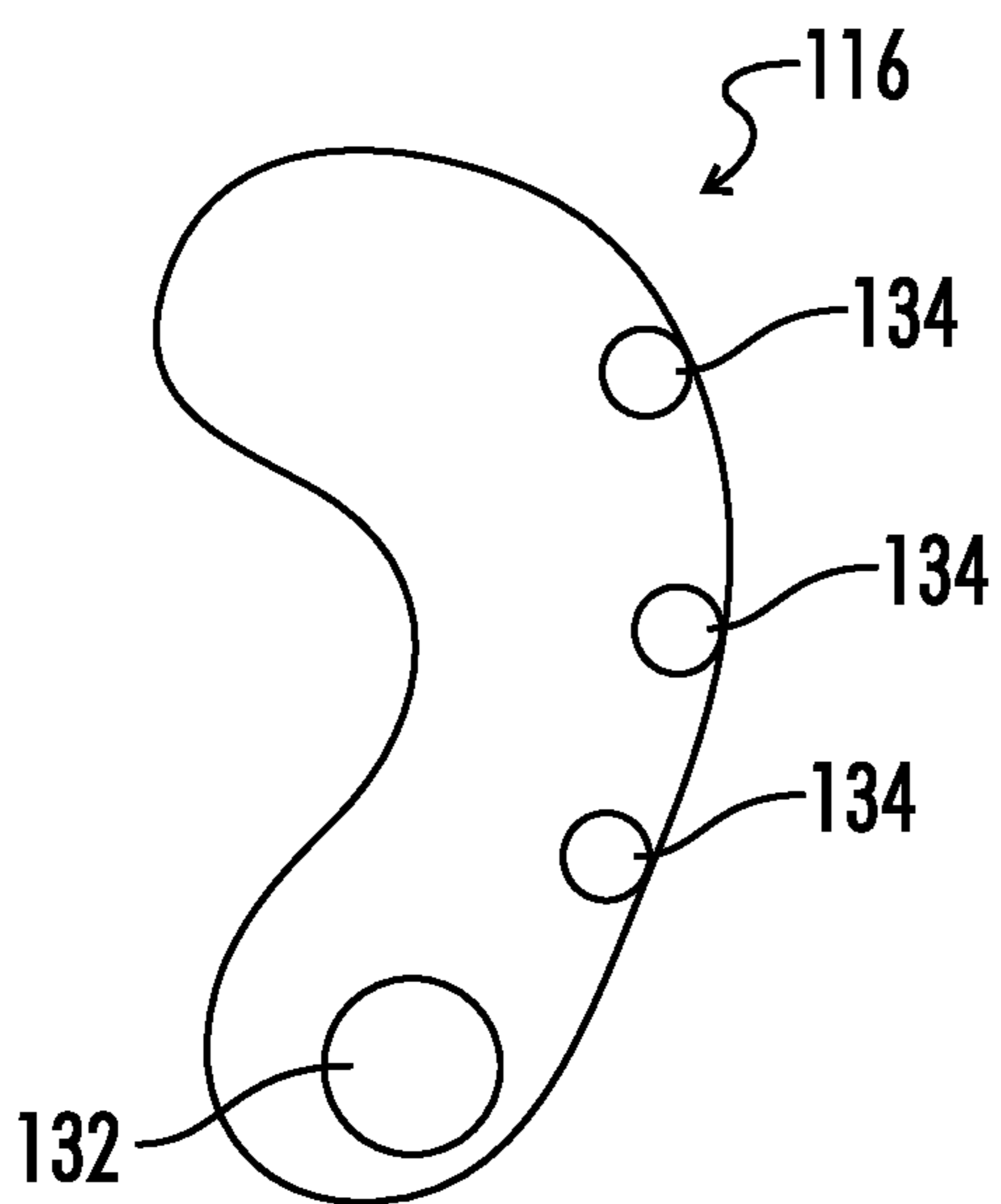

FIG. 5A

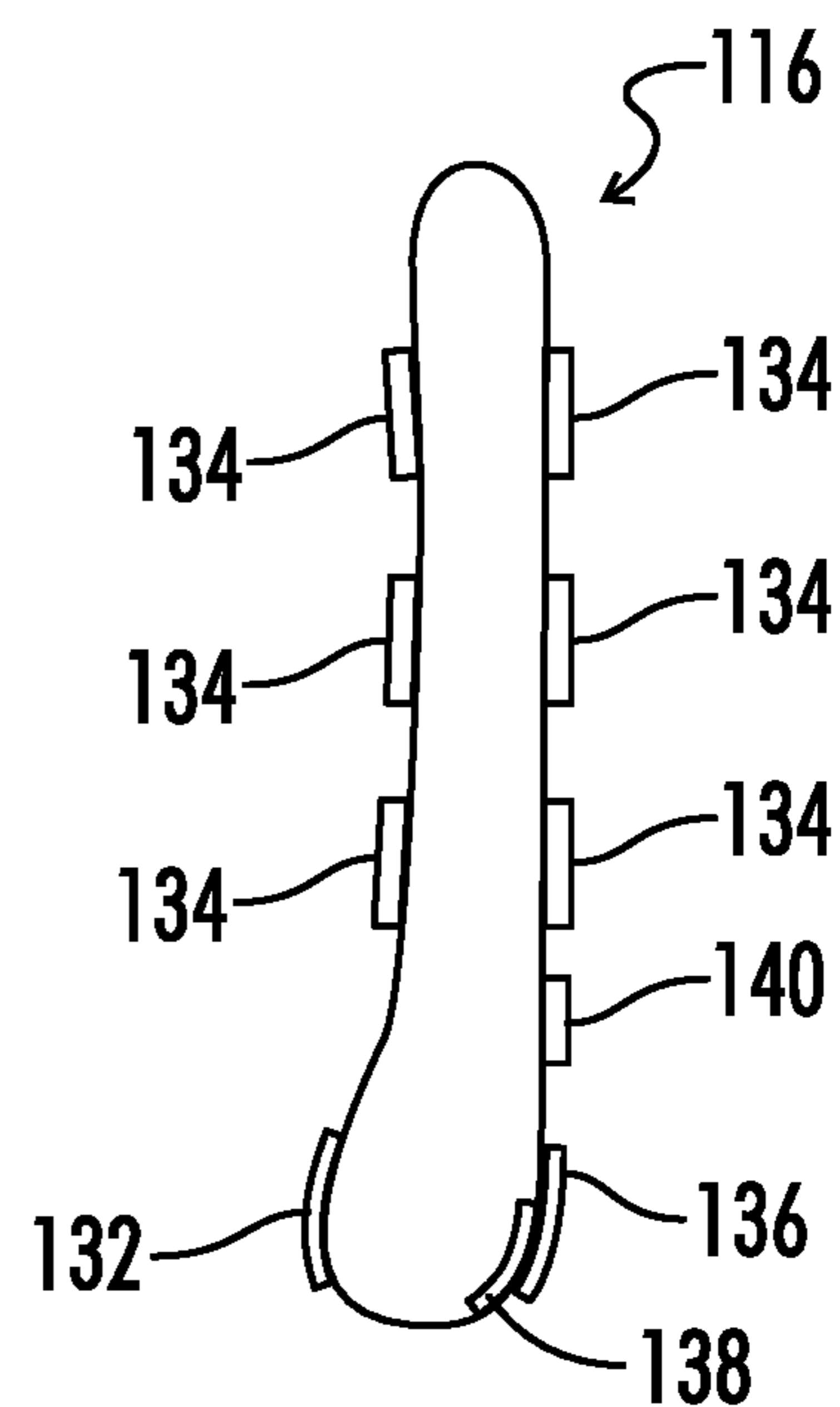

FIG. 5B

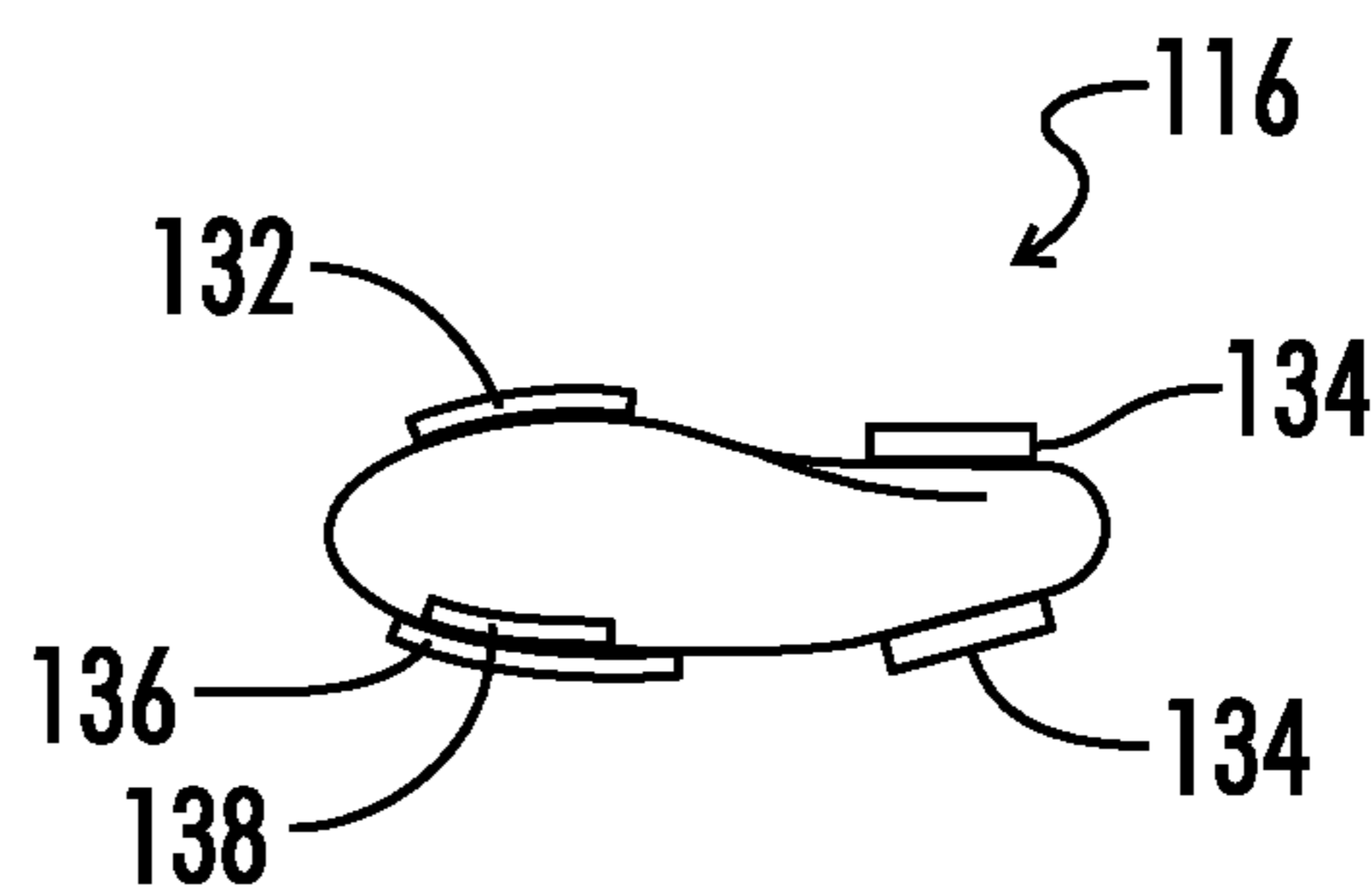

FIG. 5C

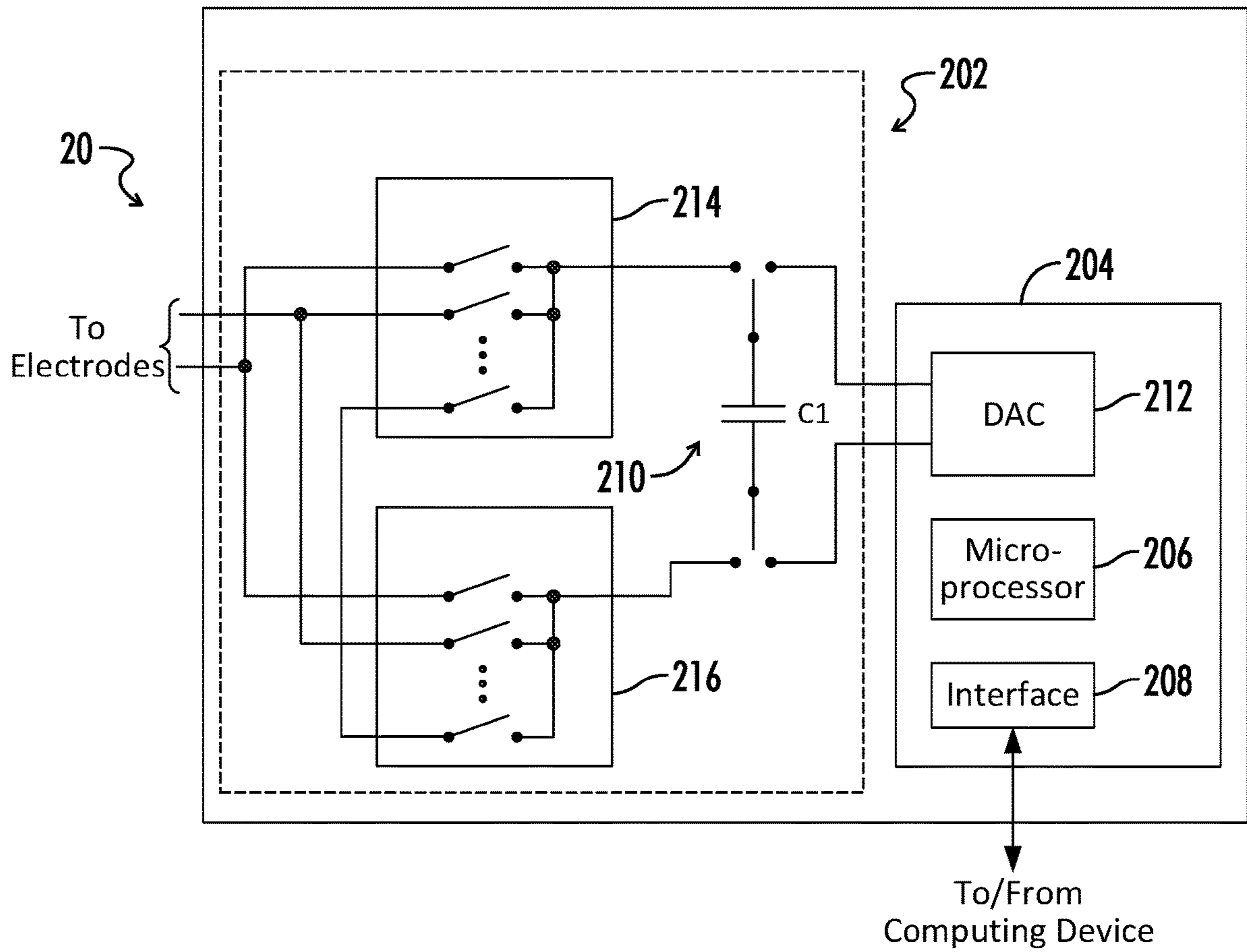

FIG. 6

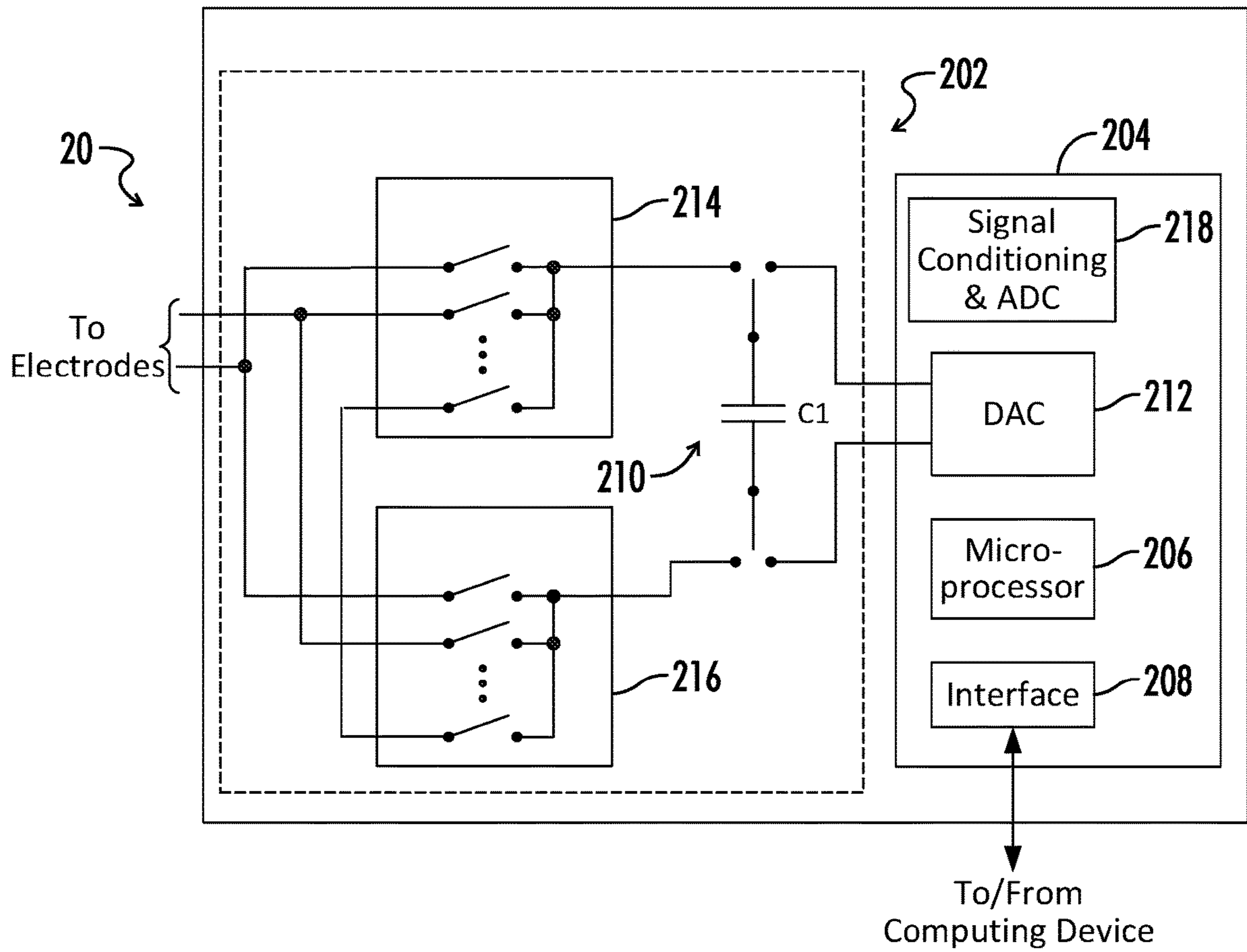

FIG. 7

1

SYSTEMS AND METHODS FOR MULTI-MODAL AND NON-INVASIVE STIMULATION OF THE NERVOUS SYSTEM

CROSS-REFERENCE TO RELATED APPLICATION

This application claims the benefit of U.S. Provisional Application No. 62/342,096, entitled "Devices and Methods for Multi-Modal Non-Invasive Stimulation of the Autonomous and Central Nervous System" and filed on May 26, 2016, which application is hereby incorporated by reference in its entirety.

BACKGROUND

The present application relates to systems and methods for multi-modal and non-invasive stimulation of the autonomous and central nervous system. More specifically, the present application relates to methods and apparatus for multi-modal augmentation of neural plasticity of the nervous system and modification of the psycho-physiological state of the user.

Electrical stimulation can be used to stimulate brain and nervous system activity for many different purposes. For example, electrical stimulation can be used to attempt to restore memory, increase cognitive function, modify psychophysiological state and for therapeutic purposes. The electrical stimulation can be applied through invasive and non-invasive techniques. Typically, non-invasive techniques are used for the convenience of the patient undergoing the electrical stimulation. Non-invasive techniques can typically involve the placement of electrodes near one or more nerves and/or the brain of the patient. The electrodes can then be used to apply a constant current to the nerves and/or brain in order to change the activity of the nerves and/or brain of the patient to get a desired response. The electrodes may also be used to apply a spatio-temporal activation pattern to the nerves and/or brain of the patient in order to target specific nerves or regions of the brain to obtain a specific response.

When electrical stimulation is being used on a patient, other forms of stimulation (e.g., visual stimulation or audible stimulation) are not typically used or require the use of separate systems having separate controls that are not integrated with the electrical stimulation controls. In addition, when attempting to monitor the results of electrical stimulation (or other stimulations), separate monitoring systems are required that can be cumbersome to the patient and require integration with the electrical stimulation system (or other system being used) in order to be able to identify potential responses to stimulation treatments.

SUMMARY

The present application generally pertains to combining multiple stimulation modalities to significantly increase the effectiveness of non-invasive stimulation. Multiple sensor and stimulation devices and modalities can be combined into a single, compact unit that minimizes the need for additional sensors or stimulation devices. The system features several subunits, referred to as sensory and stimulation devices (SSD), that are integrated into a headphone setup. The system is controlled by a centralized controller that communicates with all of the SSDs and with an external computer system that delivers learning material synchronized with the delivery of stimulation and collection of physiological signals.

2

Physiological signals can be used to assess the psychophysiological state of the user and to modulate the user's psychophysiological state in order to optimize performance and/or reach an optimum state of activation of the autonomous and central nervous system for the given application. When performing cognitive tasks a user requires an optimum arousal level. If the user's arousal level is too low or too high, the user can have suboptimal cognitive performance. The arousal level of a user can be modified using breathing, audio stimulation (binaural beats), vibration/bone conduction, photic stimulation, and non-invasive stimulation of branches of the vagus nerve. The arousal level of a user can be assessed using a combination of: a) heart rate; b) heart rate variability; c) respiration; d) respiratory sinus arrhythmia (i.e., a change of heart rate caused by respiration); e) galvanic skin response; f) brain electrical activity (e.g., electroencephalogram or EEG); g) pupil dilation; and/or h) vascular tone.

The system and combination of sensors can collect a maximum number of signals in a compact, unobtrusive unit and provide non-invasive stimulation to modulate the physiological state of the user. Optimum sensing and stimulation can be personalized to the user by combining the monitored signals and their features for the optimum assessment of the user's state and stimulation. In one embodiment, a linear combination of individual parameters with weight factors for each feature can be developed for each user. The training process for the system to assess individual weight factors may include the subjective feeling/feedback of the user, as well as, objective measures of the cognitive performance of the user for the given task.

One advantage of the present application is that it can be used for augmentation of cognition, recovery from traumatic brain injury or stroke, implementation of relaxation techniques, and for changing a state of consciousness.

Another advantage of the present application is that it can be used to improve performance or change psychophysiological state of the user.

Other features and advantages of the present application will be apparent from the following more detailed description of the identified embodiments, taken in conjunction with the accompanying drawings which show, by way of example, the principles of the application.

BRIEF DESCRIPTION OF THE DRAWINGS

FIG. 1 is a block diagram of an embodiment of a multi-modal sensor and stimulation system.

FIG. 2 is a block diagram of an embodiment of a computing device of the multi-modal sensor and stimulation system of FIG. 1.

FIG. 3 is an embodiment of the user wearable device of the multi-modal sensor and stimulation system of FIG. 1.

FIG. 4 is an embodiment of the interior components of the headphone pad of the user-wearable device of FIG. 3 relative to a user's ear.

FIG. 5A is a front view of an embodiment of the auricular SSD from FIG. 4.

FIG. 5B is a side view of an embodiment of the auricular SSD from FIG. 4.

FIG. 5C is a bottom view of an embodiment of the auricular SSD from FIG. 4.

FIG. 6 is a block diagram of an embodiment of the control unit of FIG. 1 with switched capacitor charge stimulation device.

FIG. 7 is a block diagram of an embodiment of the control unit of FIG. 1 with a switched capacitor charge stimulation device with monitoring of the stimulation site.

Wherever possible, the same reference numbers are used throughout the drawings to refer to the same or like parts.

DETAILED DESCRIPTION

The present application generally pertains to systems and methods for providing several non-invasive stimulations to a user. The user can place a device (e.g., headgear) on the user's head to receive the non-invasive stimulations. The headgear can incorporate several different types of sensory and stimulation devices (SSDs) to provide the stimulations to the user. The different types of stimulation can include electrical stimulation, audio stimulation, photic stimulation, vibration stimulation, olfactory stimulation and electromagnetic stimulation. In addition to providing stimulation to the user, the headgear can also include different sensors to measure different physiological parameters of the user. The sensors of the headgear can be used to measure the electroencephalogram, the electrocardiogram, the photoplethysmogram, the electrooculogram and/or the balistocardiograph of the user. Using the measurements from the sensors, different physiological parameters of the user can be determined such as brain activity, heart rate, blood pressure, respiration rate, etc., to assess activity of central and autonomous nervous system.

The headgear worn by the user can include a top headband that is positioned on top of the user's head and a front headband that is positioned on the user's forehead. Each of the headbands can include electrical contacts that can be used to provide both electrical stimulation to the user and to measure physiological parameters of the user. In addition, the headgear can include ear pads that are placed over the ears of the user. The ear pads can include both an ear bud placed in the ear and an SSD that is placed behind the ear. The ear bud can be used to provide audio stimulation to the user and can include a stimulation device that can be used to provide electrical stimulation to a branch of the vagus nerve. The behind the ear SSD can include electrodes that are placed in contact with both the ear of the user and the head of the user to provide both electrical stimulation to the user and to measure physiological parameters of the user. The behind the ear SSD can also include a reference electrode that is in contact with the user to provide a reference when measuring a physiological parameter of a user. The behind the ear SSD can also include a pulse oximeter in contact with the lobule of the user and a vibration device that is in contact with the user to provide vibration stimulation to the user.

All of the sensors and stimulation devices of the head gear can be in communication with a control unit. The control unit can be integrated into the headgear or can be in a separate housing that is coupled to the headgear. The control unit can send signals to and receive signals from each of the SSDs. The control unit can be in communication with a central computer that controls the operation of the SSDs of the head gear. The central computer can provide instructions to the control unit to implement a variety of different stimulation sequences to the user, including instructions to provide targeted electrical stimulation to certain areas of the brain. As the control unit receives the sensor measurements from the SSDs, the control unit can provide the measurements to the central computer. The central computer can then evaluate the user's response to the stimulations and make adjustments to the stimulations in order to achieve the desired results. Some adjustments that can be made to the

stimulations include increasing or decreasing the duration of the stimulation, increasing or decreasing the magnitude of the stimulation and/or adding or removing particular types of stimulations.

In addition, the central computer can determine an arousal level of the user, which can be used to optimize the user's cognitive learning. The arousal level of the user can be determined with a combination of physiological parameters determined from the measurements of the sensors in the headgear. The physiological parameters may or may not be weighted when determining arousal level for the user. If the physiological parameters are weighted, then each individual user may have a different set of weights in order to determine that user's optimal arousal level. Further, the central computer can customize stimulation sequences for each user in order to maximize the user's benefit from the treatment.

FIG. 1 shows a block diagram embodiment of a multi-modal sensor and stimulation system 100. The multi-modal sensor and stimulation system 100 can include a user-wearable device 110 and a computing device 30 coupled to the device 110. The device 110 can include one or more sensory and stimulation devices (SSDs) 10 that can provide different types of stimulation to the user and measure the user's response to the different stimulations. The SSDs 10 can be coupled to a control unit 20 incorporated into the device 110. The control unit 20 can send instructions or signals to the SSDs 10 to control the operation of the SSDs 10. The control unit 20 can also receive data and/or signals from the SSDs 10 indicating the user's response to the stimulations. The control unit 20 can be coupled to the computing device 30 to receive instructions from the computing device 30 for the SSDs 10 and to provide data from the SSDs 10 to the computing device 30. In one embodiment, the control unit 20 can communicate wirelessly (i.e., via electromagnetic or acoustic waves carrying a signal) with the computing device 30, but in other embodiments, it is possible for the control unit 20 to communicate with the computing device 30 over a conductive medium (e.g., a wire), fiber, or otherwise.

FIG. 2 shows an embodiment of the computing device 30. The computing device 30 may be implemented as one or more general or special-purpose computers, such as a laptop, hand-held (e.g., smartphone), desktop, or mainframe computer. The computing device 30 can include logic 32, referred to herein as "device logic," for generally controlling the operation of the computing device 30, including communicating with the control unit 20. The computing device 30 also includes sensory and stimulation logic 34 to control the operation of the SSDs 10 and to process the data and information measured by the SSDs 10. The device logic 32 and the sensory and stimulation logic 34 can be implemented in software, hardware, firmware or any combination thereof. In the computing device 30 shown in FIG. 3, the device logic 32 and the sensory and stimulation logic 34 are implemented in software and stored in memory 36 of the computing device 30. Note that the device logic 32 and the sensory and stimulation logic 34, when implemented in software, can be stored and transported on any non-transitory computer-readable medium for use by or in connection with an instruction execution apparatus (e.g., a microprocessor) that can fetch and execute instructions. In the context of this application, a "computer-readable medium" can be any device, system or technique that can contain or store a computer program for use by or in connection with an instruction execution apparatus.

The computing device 30 includes at least one conventional processing unit 38, which has processing hardware for

executing instructions stored in memory **36**. As an example, the processing unit **38** may include a digital signal processor or a central processing unit (CPU). The processing unit **38** communicates to and drives the other elements within the computing device **30** via a local interface **42**, which can include at least one bus. Furthermore, an input interface **44**, for example, a keyboard, a mouse, touchscreen, sensor or any other interface device or apparatus, can be used to input data from a user of the computing device **30**, and an output interface **46**, for example, a printer, monitor, liquid crystal display (LCD), or other display apparatus, can be used to output data to the user of the computing device **30**. Further, a communication interface **48**, such as at least one modem, may be used to communicate with control unit **20**.

FIG. **3** shows an embodiment of a user-wearable device **110**. In one embodiment, as shown in FIG. **3**, the device **110** can be a type of headgear that is worn on the head of the user. However, in other embodiments, different configurations of the device **110** can be used. The device **110** can include headphone pads **112** that are placed in proximity to one or both of the ears of the user. In one embodiment, the headphone pads **112** can be circumaural pads that surround the ear. However, in other embodiments, different configurations of the headphone pads **112** (e.g., supra-aural) can also be used. The headphone pads **112** can incorporate one or both of speakers or earbuds **114** (that operate as an SSD), one or more trigeminal SSDs **150** located near the temple between the ear and eye, and one or more auricular SSDs **116** located behind the ear. The device **110** can include a top headband **118** with one or more electrodes **120** that can provide electrical stimulation to the top of the head of the user and a front headband **122**. In one embodiment, the front headband **122** can include one or more photic SSDs **124** to provide photic stimulation to one or both of the user's eyes. In another embodiment, the photic SSDs **124** can be integrated into (or connected to) eyewear that is worn by the user. In other embodiments, the front headband **122** can include a virtual/augmented reality display or a screen/projection unit. In still other embodiments, the front headband **122** can include one or more electrodes (not shown) to provide electrical stimulation and/or a SSD (not shown) that can provide olfactory stimulation and monitoring.

FIG. **4** shows an embodiment of the interior components of the headphone pad **112** relative to a user's ear. As shown in FIG. **4**, the auricular SSD **116** can be located behind the ear lobe **130** of the user. In one embodiment, the auricular SSD **116** can be a soft anatomically shaped device that can comfortably reside behind the ear of the user for prolonged periods of time. In another embodiment, the auricular SSD **116** can have an arcuate shape to fit behind the ear of the user. As shown in FIGS. **5A-5C**, the auricular SSD **116** can include a photoplethysmogram (PPG) sensor **132** (e.g., a pulse oximeter) to measure the PPG of the user. The PPG represents blood volume pulse and can be used to measure or assess: a) heart rate (HR); b) heart rate variability (HRV); c) breathing rate (BR); and d) vascular tone using blood volume pulse or pulse travel time (PIT) as a latency of the PPG peak from the R peak in an electrocardiogram (ECG). The PPG sensor **132** can be implemented on the front of the auricular SSD **116** to allow good contact with the lobule **131** (see FIG. **2**) of the ear, which is a location that can be used for PPG sensing.

The auricular SSD **116** can also include one or more electrical contacts (or electrodes) **134** for the monitoring of heart activity (e.g., an ECG), brain electrical activity (e.g., an electroencephalogram (EEG)), or galvanic skin response (GSR). The electrodes **134** can be located on one or both

sides of the auricular SSD **116** to contact either a portion of the user's ear or a portion of the user's head (e.g., the temporal bone or the mastoid bone). An electrical contact (or electrode) **136** for the EEG reference can be located at the bottom of the auricular SSD **116** in contact with the mastoid bone or the lobule **131**. A vibrator or speaker **138** can be used to apply stimulation using bone conduction. An accelerometer **140** can be used for detection of a balistocardiograph (BCG) representing motion caused by the mechanical movement of the heart. In one embodiment, the delay between the BCG and the PPG is a function of vascular tone/blood pressure and can be used to assess the arousal of the user.

The trigeminal SSD **150** can be attached to the exterior of the headphone pad **112** in one embodiment. However, in other embodiments, the trigeminal SSD **150** can be incorporated within the headphone pad **112** such that the headphone pad **112** has an enlarged region enclosing the trigeminal SSD **150**. In still other embodiments, the trigeminal SSD **150** can be integrated into the front headband **122**. The trigeminal SSD **150** can include one or more electrodes that are positioned near the temple to provide electrical stimulation to branches of the trigeminal nerve.

The earbud **114** can be a soft anatomically shaped device that can comfortably reside in the ear with good contact with the cymba concha region **133** of the ear. Acoustic stimulation can be delivered through a speaker in the earbud **114** and the electrical stimulation of branches of the vagus nerve (VNS stimulation) can be delivered through electrical contacts **142** of a stimulator that resides on soft extension of the earbud **114** designed to fit the anatomical shape of the cymba concha region. While not shown in FIGS. **3** and **4**, the control unit **20** can be incorporated in the headphone pad **112**. However, in other embodiments, the control unit **20** may be incorporated into other portions of the device **110** (e.g., top headband **118**).

Referring back to FIG. **3**, the top headband **118** can integrate EEG sensors with stimulation electrodes **120**. In one embodiment, the placement of the sensors/stimulation electrodes **120** can follow standard EEG electrode placements, such as the international 10-20 system. The photic SSDs **124** can be integrated into a separate band near the eyes of the user, integrated into the front headband **122**, into eyeglasses or virtual reality goggles, or implemented as a modulation of the virtual or augmented personal display. The photic SSDs **124** can provide cues for the pacing of the user's breathing or generate a Steady State Visual Evoked Response (SSVER) from the user. The SSVER can be recorded with the behind the ear SSD device **116** or by sensors in the front headband **122** and used to assess the focused attention of the user. Olfactory stimulation can be implemented in a separate band close to the nose of the user or integrated into the other parts of the system, such as the front headband **122** or a virtual reality display. Olfactory stimulation can be controlled by the central computer **30** (see FIG. **1**) to provide an emotional response as a "reward" for successful execution of a task to strengthen learning by subliminal stimulation.

In one embodiment, magnetic field stimulation can be integrated into the device **110** by using coils instead of electrodes in one or more of the top headband **118**, the front headband **122** and the auricular SSD **116**.

The device **110** can be used to detect one or more the following signals from a user: an electroencephalogram (EEG); an electrooculogram (EOG); a photoplethysmogram (PPG); and a balistocardiogram (BCG). In other embodiments, the device **110** can be used to detect other signals from the user. The detected signals can be provided to the

control unit **20**, which can then send the signals to the computing device **30** for processing by the sensory and stimulation logic **34**. The EEG can be detected with electrodes in one or more of the top headband **118**, the front headband **122**, and the auricular SSD **116**. The EOG can be detected with the photic SSDs **124** and/or the front headband **122**. The PPG can be detected with the PPG sensor **132**. The BCG can be detected with accelerometer **140**.

The device **110** and the computing device **30** can also be used to detect the following physiological parameters from a user: brain electrical activity using EEG; steady state evoked potentials (SSVEP) or steady state evoked response (SSVER); eye movement and blinking using EOG; heart rate using ECG, PPG and/or BCG; heart rate variability (HRV) using ECG and/or PPG; vascular tone (i.e., the time delay between ECG/BCG and PPG for each heart beat); galvanic skin response (GSR); respiration rate and effort from PPG; respiratory sinus arrhythmia (i.e., the change of heart rate or inter-beat intervals caused by respiration) using respiratory effort and RR intervals (i.e., the interval between successive Rs in the QRS complex of the ECG wave); blood pressure assessed using latency between ECG and PPG/BCG; and arousal as a personalized weighted combination of the above parameters. In other embodiments, the device **110** and the computing device **30** can be used to detect other physiological parameters from the user.

The sensory and stimulation logic **34** can provide signals or commands to the control unit **20** of the device **110** for one or more of the following stimulation types: electrical stimulation; audio stimulation; vibration stimulation; photic stimulation; olfactory stimulation; and electromagnetic field stimulation. In one embodiment, electromagnetic field stimulation can be integrated into the device **110** by using coils instead of electrodes in one or more of the top headband **118**, the front headband **122** and the auricular SSD **116**. Olfactory stimulation can be implemented into the device **110** using a separate band close to the nose of the user or integrated into the other parts of the system, such as the front headband **122** or a virtual reality display. Olfactory stimulation can be controlled by the central computer **30** (see FIG. **1**) to provide an emotional response as a “reward” for successful execution of a task to strengthen learning by subliminal stimulation.

Photic stimulation may directly drive the visual cortex and create steady state visual evoked potentials across the cortex that can be measured and analyzed using EEG electrodes in the top headband **118**, the front headband **122** and the auricular SSD **116**. Vibration stimulation can provide similar binaural beats stimulation or direct stimulation at the target frequency (e.g., at the frequency of targeted brain electrical activity) using the vibrational device **138**. Audio stimulation using the earbud **114** can use binaural beats to generate brain electrical activity at the precise frequency of the difference in frequencies between the left and right ear.

The system **100** can implement electrical stimulation in the user as one or more of current stimulation with a constant or variable current (e.g., transcranial direct current stimulation or tDCS), voltage stimulation with a constant voltage or charge stimulation. Charge based stimulation can be used to generate a precise charge and then apply it to selected electrodes for stimulation.

FIG. **6** shows of an embodiment of the control unit **20** with a switched capacitor charge stimulation circuit or stimulator **202** controlled by a controller **204**. The controller **204** can control the stimulator **202** in real-time with a

microprocessor **206** that communicates with the computing device **30** through interface **208**. Microprocessor **206** controls switches of a switched capacitor **210** to charge or discharge a capacitor **C1**. During charging of the capacitor **C1**, the switched capacitor **210** is connected to the digital to analog converter (DAC) **212** that generates an appropriate voltage as instructed by the microprocessor **206**. The voltage provided by the DAC **212** can be either positive or negative, depending on the required stimulation and the corresponding electrodes selected to apply the stimulation. The total charge (**Q**) on the capacitor **C1** of the switched capacitor **210** can be based on the output voltage (**V**) from the DAC **212** and the capacitance (**C**) of the capacitor **C1**. In one embodiment, the total charge **Q** for the capacitor **C1** can be determined by multiplying the output voltage **V** by the capacitance **C**.

Before applying the stimulation, the microprocessor **206** can control a first analog multiplexer **214** and a second analog multiplexer **216** to select the electrodes to receive stimulation. In one embodiment, the electrodes can be located in one or more of the top headband **118**, the front headband **122** and the auricular SSD **116**. As shown in FIG. **6**, the stimulator **202** has leads or connections for two electrodes, but the stimulator **202** may have leads or connections for one electrode or more than two electrodes in other embodiments depending on the requirements of the application and the number of outputs in the first and second analog multiplexers **214**, **216**.

FIG. **7** shows of an embodiment of the control unit **20** with a switched capacitor charge stimulation circuit or stimulator **202** with monitoring of the stimulation site. For some applications, stimulation can be enhanced by applying stimulation synchronized with the native activity of the nervous system. Thus, monitoring of the stimulation site may be required in order to effectively perform the stimulation. Similar to the embodiment shown in FIG. **6**, the stimulator **202** can be connected to the controller **204**. However, in the embodiment of FIG. **7**, the controller **204** can include a signal conditioning circuit and analog to digital converter (ADC) **218** that is controlled by the microprocessor **206**.

The signal conditioning circuit and ADC **218** can be connected to the stimulation side of the switched capacitor **210**. By having the signal conditioning circuit and ADC **218** connected to the microprocessor **206**, the microprocessor **206** can monitor the voltage between selected electrodes before and after a stimulation caused by connecting the capacitor **C1** to the corresponding electrodes. After reviewing the corresponding voltage between the electrodes, the microprocessor **206** can adjust the charge provided to the switched capacitor **210** by the DAC **212** in order to get a desired voltage between the electrodes.

In one embodiment, the system **100** can be used to create spatio-temporal activation patterns of stimulation using software controlled stimulation with charges of different intensity and polarity occurring at different times and in different electrodes. The sensory and stimulation logic **34** of computing device **30** can be used to create the spatio-temporal patterns and to control the intensity, polarity and timing of the charges provided by the stimulator **202** to the electrodes via communications with the controller **204**. In addition, the sensory and stimulation logic **34** of computing device **30** can be used to provide stimulations at specific times and specific locations in the device **110** to obtain a better localization or focus of stimulation in the brain and nervous system. For example, specific electrodes in the top headband **118**, the front headband **122**, the trigeminal SSD **150** and the auricu-

lar SSD **116** can be used to obtain a more focused stimulation of a region of the brain or nervous system.

In one embodiment, the system **100** can facilitate non-invasive stimulation with real-time monitoring of users for numerous applications. For example, the possible applica-
 5 tions for the system **100** can include improving neural plasticity, improving cognitive performance and providing relaxation techniques. To improve neural plasticity, the system **100** can provide a multi-modal, personalized combination of stimulations combined with the delivery of new
 10 material, or new exercise. Some examples can include learning or rehabilitation, such as stroke or traumatic brain injury rehabilitation. Other applications also include treatment of the post-traumatic stress disorder desensitization and reprocessing.

To improve cognitive performance, the system **100** can perform real-time monitoring of signals that allows the real-time assessment of the arousal of the user, while providing different stimulation modalities to facilitate modulation of arousal and overall psychophysiological state by
 20 keeping the user “in the zone.”

To provide relaxation techniques, the system **100** can provide multimodal stimulation and physiological entrainment to create deeply relaxed state in the user. Binaural beat
 25 entrainment using natural sounds can be combined with photic stimulation to transition the brain electrical activity of the user from Alpha to lower Alpha and Theta. Photic stimulation can create entrainment of breathing from the natural initial state as detected using sensors to a relaxed,
 30 slower, and deeper breathing. Optical stimulation can provide cues for breathing phases. The monitoring of the heart rate, heart rate variability, and respiratory sinus arrhythmia can provide assessment of strain to optimize basic physiology (breathing and heart rate) to the optimum level for the
 35 current state of the user. Closed loop control, entrainment, and stimulation by the system **100** can facilitate modification of the physiological state of the user in minimum time.

In one embodiment, the system **100** can be used to implement an interval performance boost methodology. The interval performance boost methodology can include a pre-
 40 sentation phase, a learning phase and a consolidation phase. The presentation phase combines stimulations for a personalized optimization of the user’s arousal to improve the user’s cognitive performance and focused attention. The learning phase uses stimulation of memorization and repetition of the most important concepts to be learned by the
 45 user. The consolidation phase can create a deeply relaxed state with heightened awareness in the user by using sensory withdrawal with brain entrainment to consolidate the new material to be learned by the user.

In one embodiment, the multi-modal stimulations provided by the system **100** may be user-configurable. A user of the system may select the modes of stimulation to be
 50 performed on the user and may select the amounts (or percentages) that the selected stimulations are applied to the user. Once the user has selected the modes and amounts of stimulation, the computing device **30** can develop a stimulation regimen for the user based on the user-configured parameters. For example, a user may select to receive
 55 electrical stimulation for 50% of the regimen, audio stimulation for 30% of the regimen and photic stimulation for 20% of the regimen while foregoing other types of stimulation. In another embodiment, relative percentage of intensity of individual modalities might be selected according to user’s preferences.

Although the figures herein may show a specific order of method steps, the order of the steps may differ from what is

depicted. Also, two or more steps may be performed concurrently or with partial concurrence. Variations in step performance can depend on the software and hardware systems chosen and on designer choice. All such variations
 5 are within the scope of the application. Software implementations could be accomplished with standard programming techniques, with rule based logic and other logic to accomplish the various connection steps, processing steps, comparison steps and decision steps.

10 It should be understood that the identified embodiments are offered by way of example only. Other substitutions, modifications, changes and omissions may be made in the design, operating conditions and arrangement of the embodiments without departing from the scope of the present application. Accordingly, the present application is not
 15 limited to a particular embodiment, but extends to various modifications that nevertheless fall within the scope of the application. It should also be understood that the phraseology and terminology employed herein is for the purpose of description only and should not be regarded as limiting.

What is claimed is:

1. A user-wearable device to provide stimulation to the nervous system of a user, the device comprising:

a headband configured to be worn on a head of the user, the headband comprising at least one electrode configured to provide electrical stimulation to the user; and
 25 a headphone pad coupled to the headband and positioned in proximity to an ear of the user, the headphone pad comprising:

a first sensory and stimulation device (SSD) configured to provide a first type of stimulation to the user; and
 30 a second SSD configured to provide a second type of stimulation to the user, wherein the second type of stimulation provided by the second SSD is different from the first type of stimulation provided by the first SSD, the second SSD comprising a sensor positioned in contact with the ear of the user to measure a physiological parameter of the user,

wherein the electrical stimulation provided by the at least one electrode, the first type of stimulation provided by the first SSD and the second type of stimulation provided by the second SSD are adjustable by a control unit in response to the measured physiological parameter of the user to obtain a preselected arousal level from the user.

2. The device of claim **1**, wherein the headband is a first headband and the device further comprises a second headband coupled to the first headband and configured to be worn on the forehead of the user, the second headband comprising
 50 a third SSD configured to provide a third type of stimulation to the user.

3. The device of claim **2**, wherein the at least one electrode is an at least one first electrode, the third SSD comprises at least one of a photic SSD or at least one second electrode, the photic SSD coupled to the second headband and positioned in proximity to an eye of the user, the photic SSD configured to provide photic stimulation to the user, and the at least one second electrode configured to provide electrical stimulation to the user.

4. The device of claim **1**, further comprising a third SSD positioned in proximity to an eye of the user and configured to provide photic stimulation to the user.

5. The device of claim **1**, further comprising a computing device in communication with the control unit, the computing device configured to generate commands to the control unit to control operation of the at least one electrode, the first SSD and the second SSD.

11

6. The device of claim 1, wherein the first SSD comprises an earbud positioned in proximity to the cymba concha region of the ear, the earbud configured to provide acoustic stimulation to the user.

7. The device of claim 6, wherein the earbud comprises an extension portion having at least one electrical contact, the at least one electrical contact configured to provide electrical stimulation to a branch of a vagus nerve.

8. The device of claim 1, further comprising a third SSD positioned in proximity to a nose of the user and configured to provide olfactory stimulation to the user.

9. The device of claim 1, wherein the at least one electrode is an at least one first electrode, the second SSD is positioned behind the ear of the user, the second SSD having a first side and a second side opposite the first side, the second SSD comprises at least one second electrode positioned on at least one of the first side of the second SSD or the second side of the second SSD, the at least one second electrode configured to provide electrical stimulation to the user.

10. The device of claim 9, wherein the at least one second electrode comprises a first plurality of second electrodes positioned on the first side of the second SSD for contacting the ear of the user and a second plurality of second electrodes positioned on the second side of the second SSD for contacting a head of the user.

11. The device of claim 9, wherein the headphone pad further comprises a third SSD positioned on an exterior portion of the headphone pad, the third SSD comprising at least one third electrode configured to provide electrical stimulation to the user, wherein one or more of the at least one first electrode, the at least one second electrode and the at least one third electrode are controllable by the control unit to apply a spatio-temporal activation pattern to the user to focus stimulation on an area of a brain of the user.

12. The device of claim 9, wherein the at least one second electrode is configured to monitor at least one of heart activity, brain electrical activity or galvanic skin response of the user.

13. The device of claim 12, wherein the control unit is configured to adjust the electrical stimulation provided by the at least one electrode, the first type of stimulation provided by the first SSD and the electrical stimulation provided by the at least one second electrode in response to the measured physiological parameter of the user and the monitored at least one of heart activity, brain electrical activity or galvanic skin response.

14. The device of claim 1, wherein the at least one electrode is an at least one first electrode, the headphone pad further comprises a third SSD positioned on an exterior portion of the headphone pad, the third SSD comprising at least one second electrode configured to provide electrical stimulation to the user.

12

15. The device of claim 1, wherein the second SSD comprises a vibrational device configured to apply stimulation using bone conduction.

16. The device of claim 1, wherein the control unit is configured to adjust at least one of the electrical stimulation, the first type of stimulation or the second type of stimulation by increasing or decreasing the duration of the corresponding stimulation.

17. The device of claim 1, wherein the control unit is configured to adjust at least one of the electrical stimulation, the first type of stimulation or the second type of stimulation by increasing or decreasing the magnitude of the corresponding stimulation.

18. The device of claim 1, wherein the sensor is positioned to contact a lobule of the ear of the user and configured to measure a photoplethysmogram of the user.

19. A system to provide stimulation to the nervous system of a user, the system comprising:

a headband configured to be worn on a head of the user, the headband comprising at least one electrode configured to provide electrical stimulation to the user;

a headphone pad coupled to the headband and positioned in proximity to an ear of the user, the headphone pad comprising:

a first sensory and stimulation device (SSD) configured to provide a first type of stimulation to the user; and a second SSD configured to provide a second type of stimulation to the user, wherein the second type of stimulation provided by the second SSD is different from the first type of stimulation provided by the first SSD, the second SSD comprising a sensor positioned in contact with the ear of the user to measure a physiological parameter of the user; and

a control unit in communication with the at least one electrode, the first SSD, and the second SSD, the control unit configured to adjust the electrical stimulation provided by the at least one electrode, the first type of stimulation provided by the first SSD and the second type of stimulation provided by the second SSD in response to the measured physiological parameter of the user to obtain a preselected arousal level from the user.

20. The system of claim 19, wherein the control unit is configured to receive the measured physiological parameter of the user from the sensor, evaluate the measured physiological parameter to determine an arousal level of the user, and calculate an adjustment to the electrical stimulation provided by the at least one electrode, the first type of stimulation provided by the first SSD and the electrical stimulation provided by the at least one second electrode based on the determined arousal level of the user.

* * * * *