



US011360048B2

(12) **United States Patent**  
**Generazio**

(10) **Patent No.:** **US 11,360,048 B2**  
(45) **Date of Patent:** **Jun. 14, 2022**

(54) **METHOD FOR PHONON ASSISTED  
CREATION AND ANNIHILATION OF  
SUBSURFACE ELECTRIC DIPOLES**

(58) **Field of Classification Search**  
CPC ..... G01N 27/60  
See application file for complete search history.

(71) Applicant: **UNITED STATES OF AMERICA AS  
REPRESENTED BY THE  
ADMINISTRATOR OF NASA,**  
Washington, DC (US)

(56) **References Cited**

U.S. PATENT DOCUMENTS

3,273,397 A 9/1966 Forward  
4,931,740 A 6/1990 Hassanzadeh et al.  
5,019,804 A 5/1991 Fraden  
(Continued)

(72) Inventor: **Edward R. Generazio,** Yorktown, VA  
(US)

FOREIGN PATENT DOCUMENTS

GB 2132357 A 7/1984  
WO 2002067015 A1 8/2002  
WO 2008152588 A2 12/2008

(73) Assignee: **UNITED STATES OF AMERICA AS  
REPRESENTED BY THE  
ADMINISTRATOR OF NASA,**  
Washington, DC (US)

OTHER PUBLICATIONS

U.S. Appl. No. 15/177,798 to Generazio. (filed Jun. 9, 2016).  
(Continued)

(\* ) Notice: Subject to any disclaimer, the term of this  
patent is extended or adjusted under 35  
U.S.C. 154(b) by 0 days.

(21) Appl. No.: **17/158,575**

*Primary Examiner* — Noam Reisner  
(74) *Attorney, Agent, or Firm* — Shawn P. Gorman;  
Robin W. Edwards; Helen M. Galus

(22) Filed: **Jan. 26, 2021**

(65) **Prior Publication Data**

US 2021/0148857 A1 May 20, 2021

**Related U.S. Application Data**

(62) Division of application No. 15/647,553, filed on Jul.  
12, 2017, now Pat. No. 10,900,930.

(60) Provisional application No. 62/448,130, filed on Jan.  
19, 2017, provisional application No. 62/362,815,  
filed on Jul. 15, 2016.

(57) **ABSTRACT**

Methods and systems are disclosed for dynamically creating  
and annihilating subsurface electric dipoles having variable  
strength and variable alignment. The ability of various  
embodiments to create, annihilate, and control subsurface  
dipoles may be a useful technology for wide variety of  
applications including the nondestructive testing of materi-  
als and structures, for generating and receiving directed and  
omni-directional variable amplitude and frequency trans-  
mission waves without the need for conductive antennas, for  
phonon to electromagnetic power conversion, for materials  
and manufacturing process control, atomic and nanoparticle  
alignment, and for control and utilization as medical thera-  
pies.

(51) **Int. Cl.**  
**G01N 27/60** (2006.01)  
**G01N 27/00** (2006.01)

(52) **U.S. Cl.**  
CPC ..... **G01N 27/60** (2013.01); **G01N 27/007**  
(2013.01)

**19 Claims, 8 Drawing Sheets**

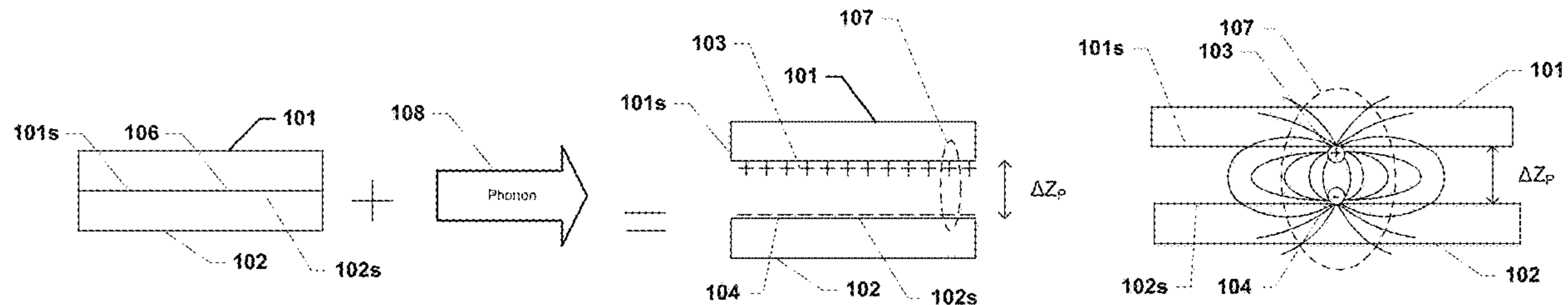

(56)

References Cited

U.S. PATENT DOCUMENTS

5,164,673 A 11/1992 Rosener  
 5,430,381 A 7/1995 Dower  
 5,986,456 A 11/1999 Yamashita  
 6,025,726 A 2/2000 Gershenfeld et al.  
 6,031,378 A 2/2000 Rosin  
 6,645,144 B1\* 11/2003 Wen ..... G01N 29/0609  
 600/407  
 6,661,115 B2 12/2003 Lester  
 6,661,232 B1 12/2003 Horiguchi  
 6,762,726 B2 7/2004 Alden  
 6,842,697 B1 1/2005 Millar et al.  
 7,119,553 B2 10/2006 Yang et al.  
 7,154,275 B2 12/2006 Zank et al.  
 7,242,298 B2 7/2007 Cehelnik  
 7,295,019 B2 11/2007 Yang et al.  
 7,330,032 B2 2/2008 Donnangelo  
 7,471,089 B2 12/2008 Zerilli et al.  
 7,568,630 B2\* 8/2009 Richardson ..... G06K 19/067  
 235/375  
 9,279,719 B2 3/2016 Generazio  
 2006/0071669 A1 4/2006 Funato et al.  
 2006/0164094 A1 7/2006 Golder et al.  
 2007/0040545 A1 2/2007 Takiguchi  
 2008/0246485 A1 10/2008 Hibbs et al.  
 2008/0303530 A1 12/2008 Coutsonitros et al.  
 2009/0284405 A1 11/2009 Salmon et al.  
 2009/0295366 A1 12/2009 Cehelnik  
 2009/0295644 A1 12/2009 Curran et al.  
 2009/0309604 A1 12/2009 Zhang  
 2010/0095257 A1 4/2010 Koshiishi et al.  
 2010/0250140 A1 9/2010 Constable et al.  
 2010/0259272 A1 10/2010 Care  
 2010/0271291 A1 10/2010 Care  
 2011/0062968 A1 3/2011 Renno et al.

2012/0013354 A1 1/2012 Bowler  
 2012/0092019 A1 4/2012 Blum  
 2012/0199755 A1 8/2012 Generazio  
 2012/0235539 A1 9/2012 Bibl et al.  
 2014/0104980 A1 4/2014 Sava et al.  
 2014/0125358 A1 5/2014 Dawson et al.  
 2014/0346058 A1 11/2014 Robitzki et al.  
 2015/0137825 A1 5/2015 Generazio  
 2015/0298174 A1 10/2015 Bibl et al.  
 2016/0049885 A1 2/2016 Generazo  
 2016/0315561 A1\* 10/2016 Shin ..... H02N 1/04

OTHER PUBLICATIONS

Jackson, John D., "Classical Electrodynamics," Third Edition Book, 1999, Hoboken, New Jersey, United States John Wiley & Sons, p. 52.  
 Generazio, E. R., "Electric Potential and Electric Field Imaging with Applications," Materials Evaluation, Nov. 2015, pp. 1479-1448, vol. 73, No. 11.  
<https://ocw.mit.edu/resources/res-6-002-electromagnetic-field-theory-a-problem-solving-approach-spring-2008/textbook-contents/>—Chapter 3. p. 143, Accessed.  
 Generazio, E. R. et al., "Free-Carrier Absorption in Quantizing Magnetic Fields," Physical Review B, Dec. 13, 1979, pp. 5162-5167, vol. 29, No. 12.  
 AlphaLab Inc. "The TriboElectric Series" <https://www.trifield.com/content/tribo-electric-series/>. Visited at least as early as Oct. 2016.  
 Halliday, D. et al., "Fundamentals of Physics," 2005, pp. 421-423, Hoboken, John Wiley & Sons, Inc., New Jersey.  
 Horowitz, Paul and Hill, Winfield, "The Art of Electronics", 2nd Ed., Cambridge University Press, pp. 113-173, 1989.  
 Fairchild Semiconductor Corporation, Junction Field Effect Transistor (JFET), <http://www.fairchildsemi.com/ds/mp/mpf102.pdf>, 2004.

\* cited by examiner

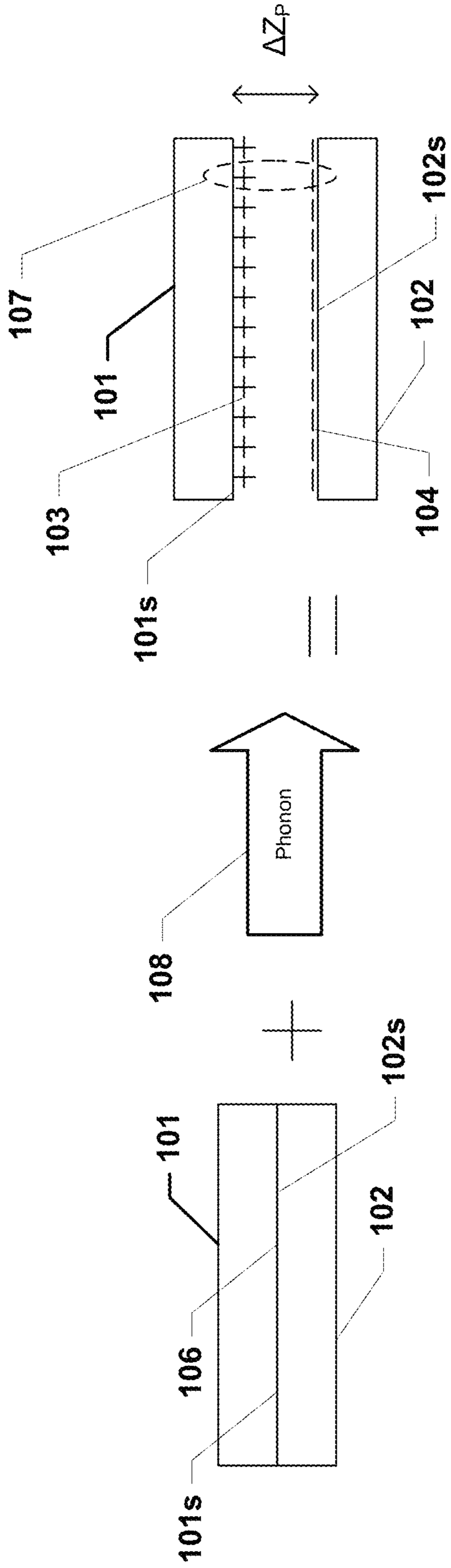

FIG. 1A

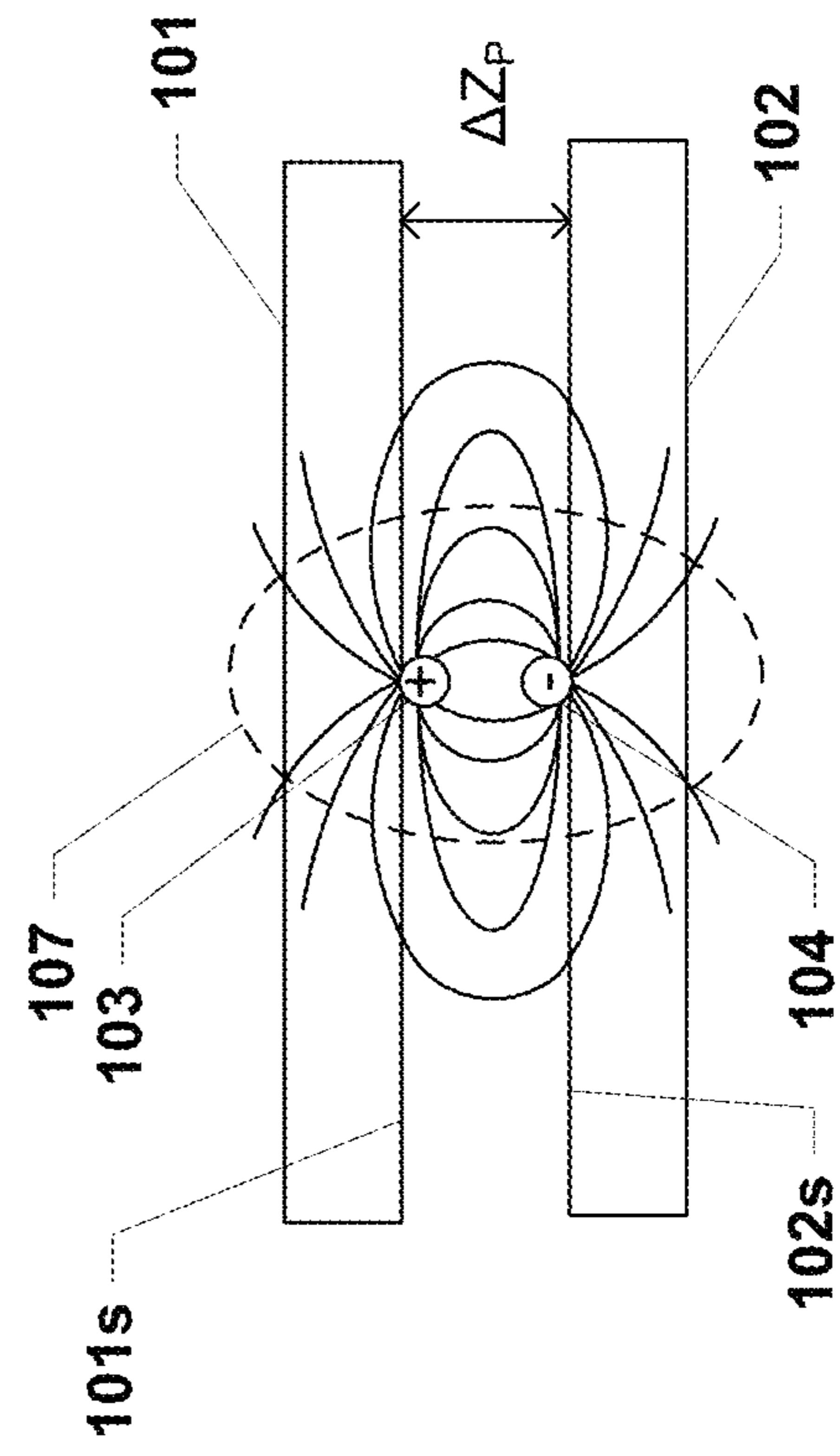

FIG. 1B

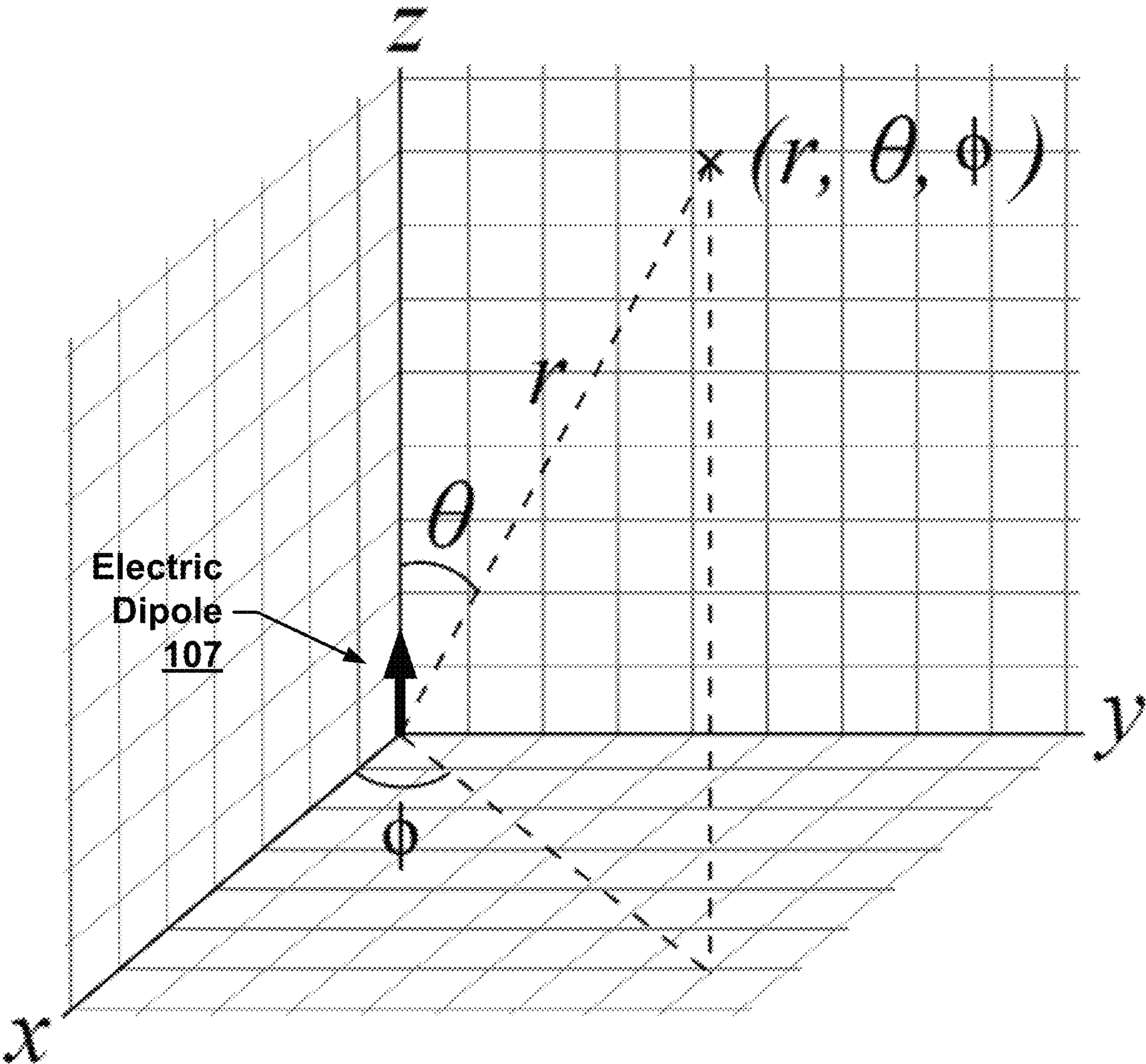

FIG. 2

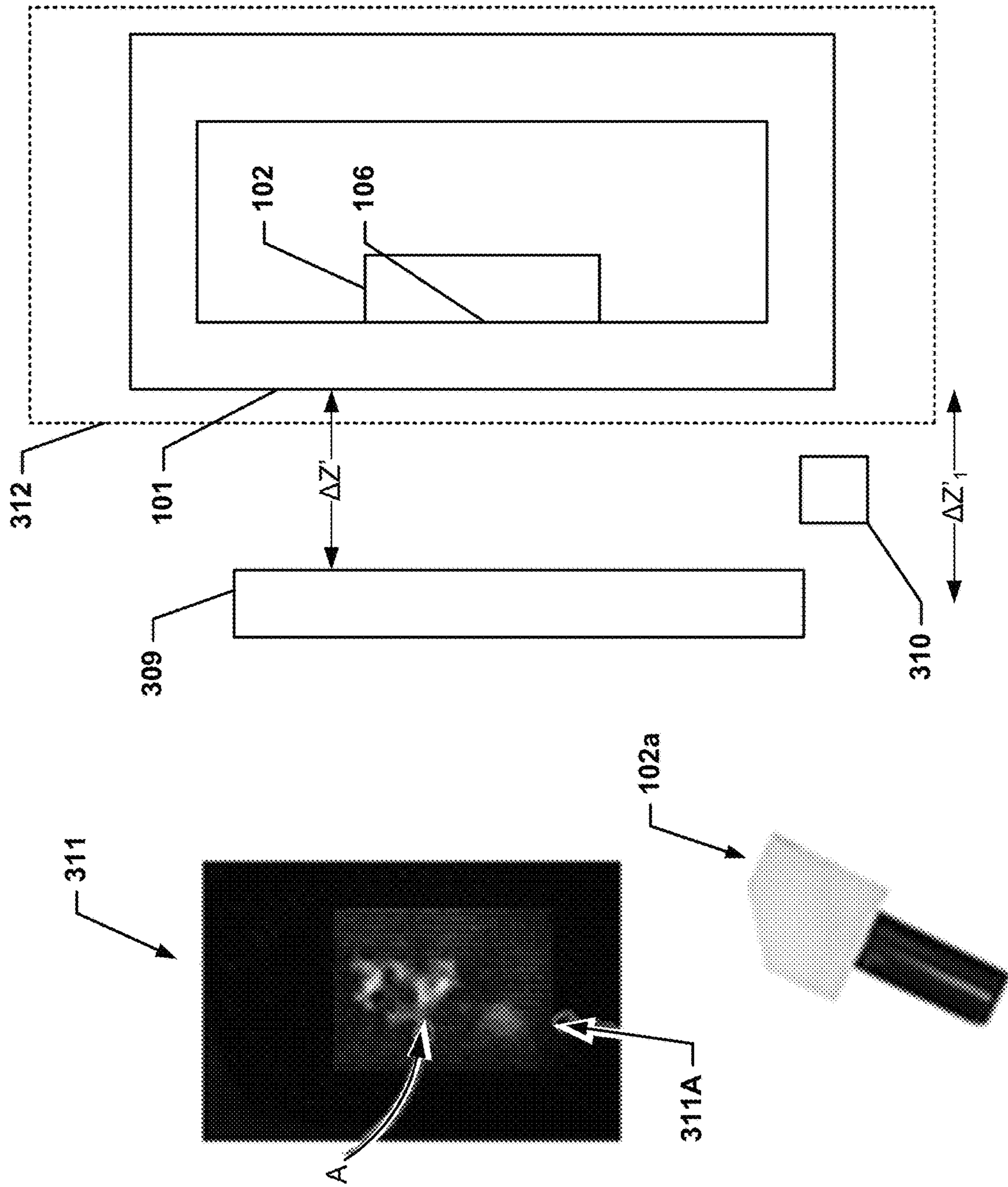

FIG. 3A

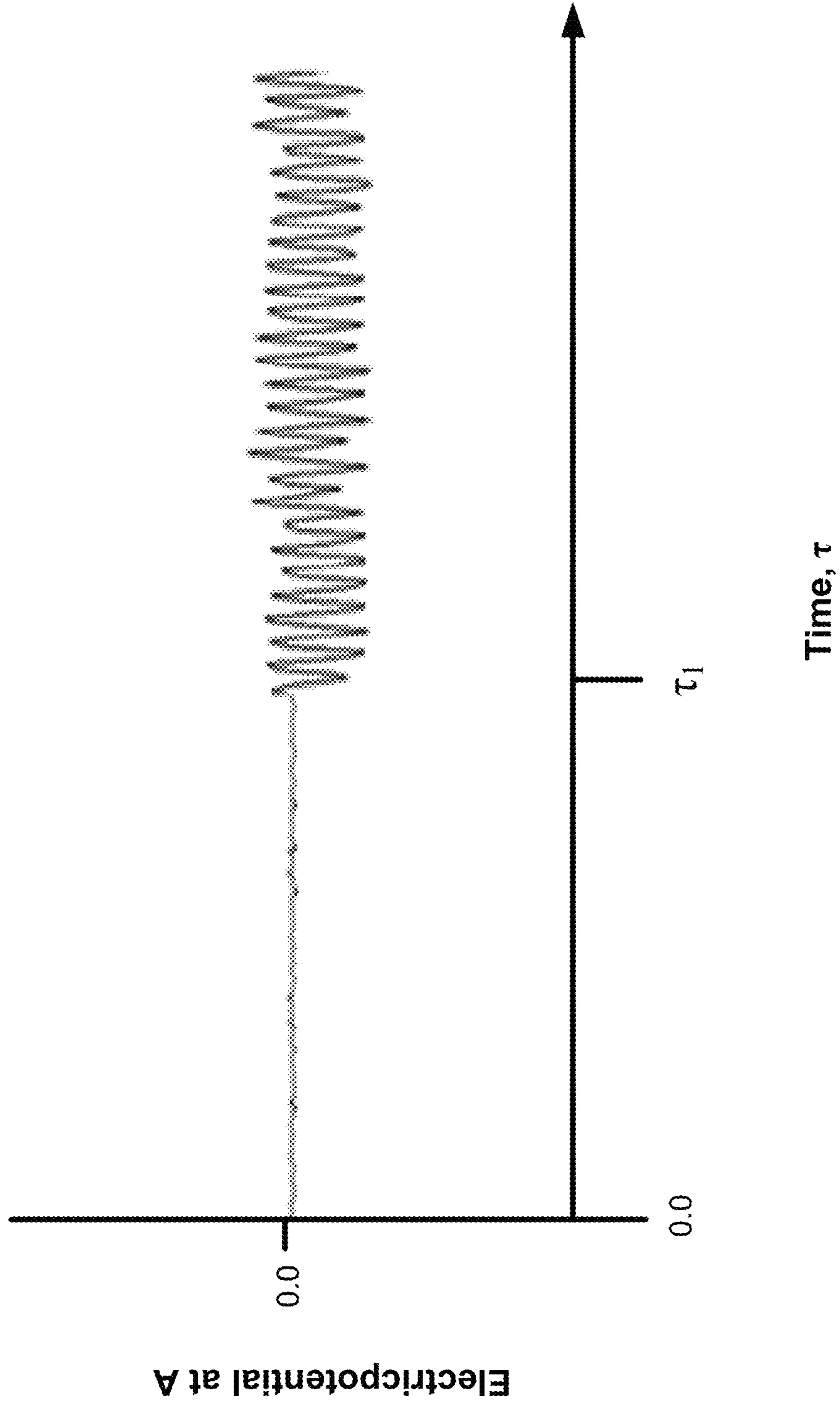

FIG. 3B

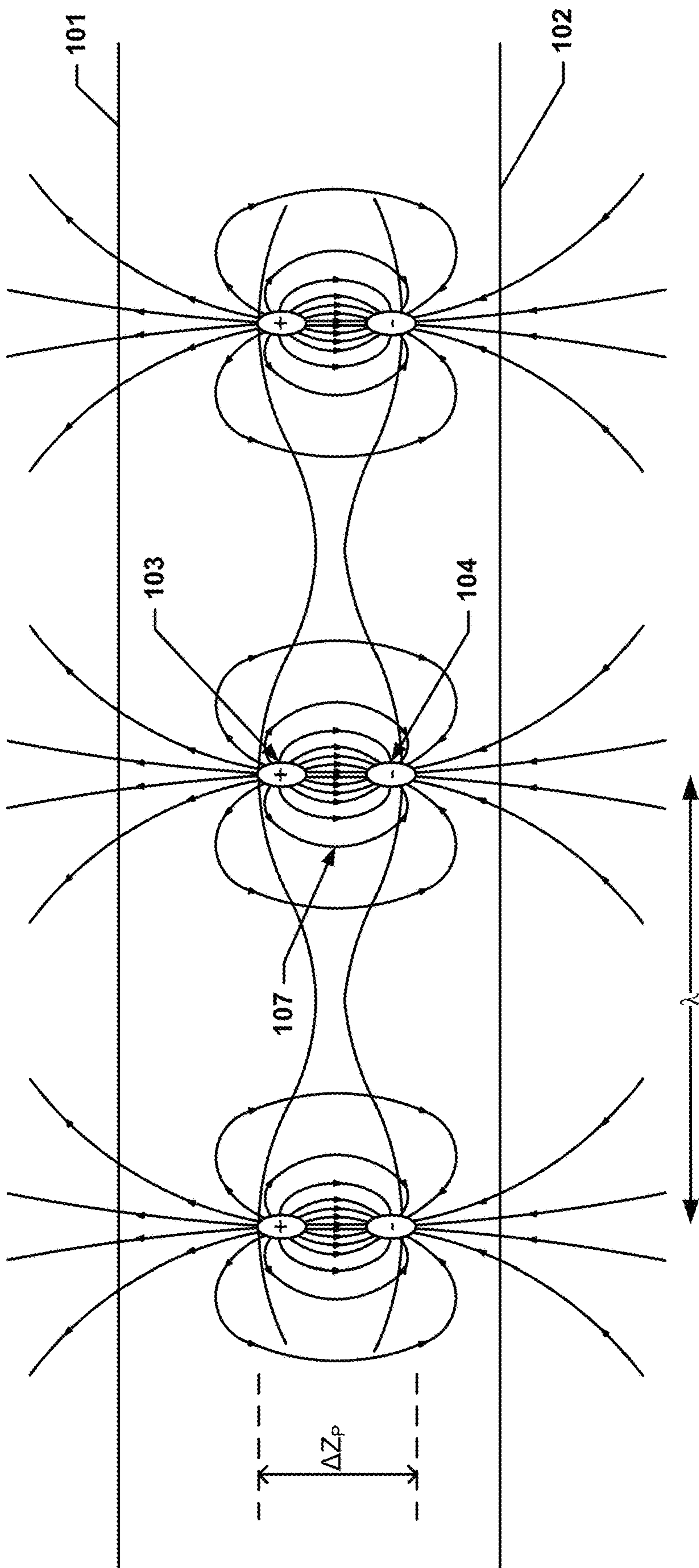

FIG. 4

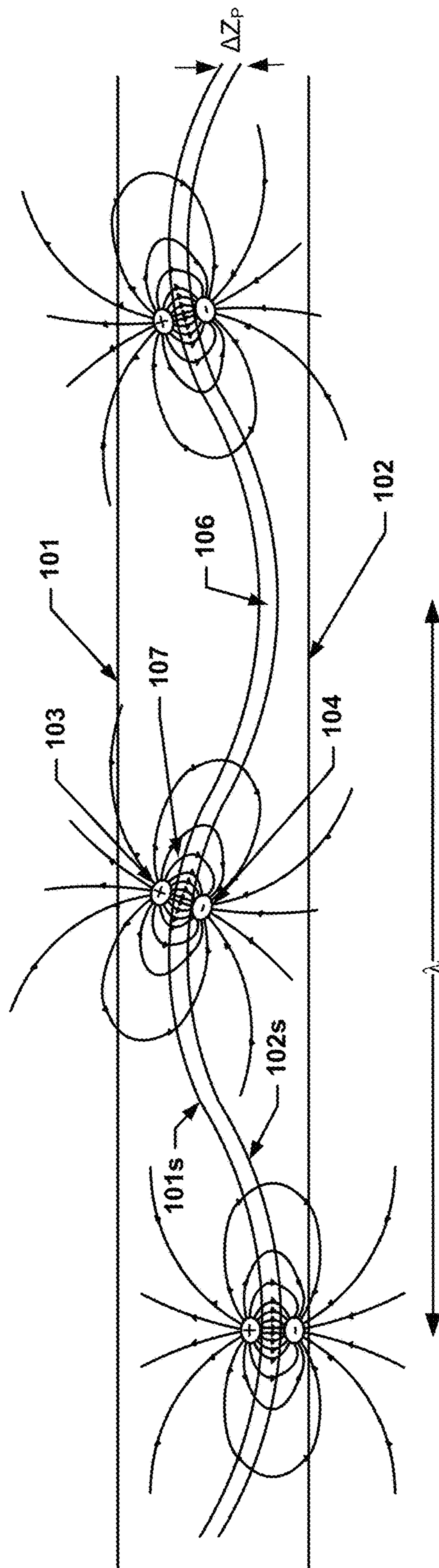

FIG. 5



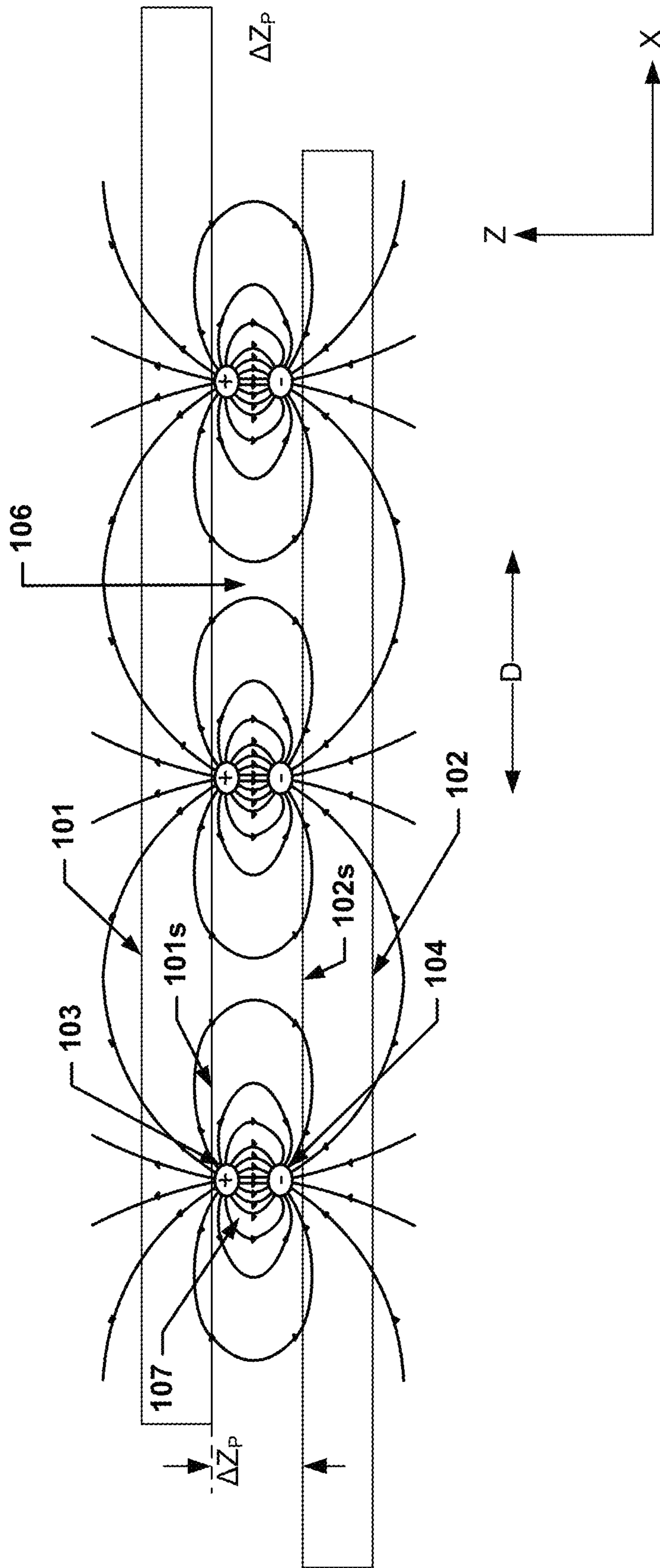

FIG. 6

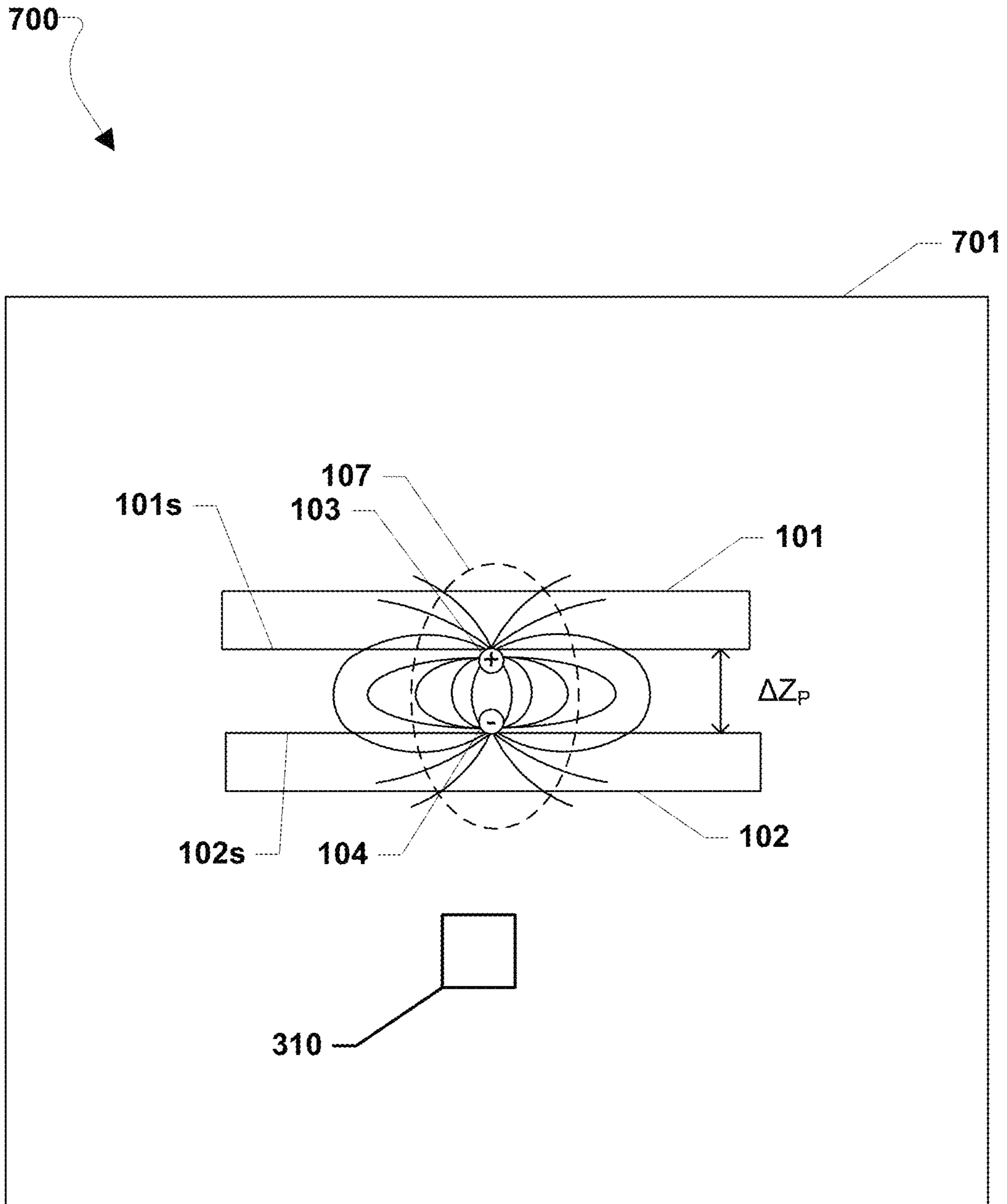

FIG. 7

1

## METHOD FOR PHONON ASSISTED CREATION AND ANNIHILATION OF SUBSURFACE ELECTRIC DIPOLES

### CROSS-REFERENCE TO RELATED APPLICATION(S)

This patent application is a divisional of and claims the benefit of and priority to U.S. Non-Provisional patent application Ser. No. 15/647,553 titled "Method for Phonon Assisted Creation and Annihilation of Subsurface Electric Dipoles" filed on Jul. 12, 2017, which claims the benefit of and priority to U.S. Provisional Patent Application No. 62/448,130 titled "Method for Phonon Assisted Creation and Annihilation of Subsurface Electric Dipoles" filed Jan. 19, 2017 and U.S. Provisional Patent Application 62/362,815 titled "Identification and Characterization of Remote Objects by Charge Tunneling, Injection, and Distribution" filed Jul. 15, 2016. The contents of which are hereby incorporated by reference in their entireties.

### STATEMENT REGARDING FEDERALLY SPONSORED RESEARCH OR DEVELOPMENT

The invention described herein was made by an employee of the United States Government and may be manufactured and used by or for the Government of the United States of America for governmental purposes without the payment of any royalties thereon or therefore.

### OVERVIEW

The present disclosure relates to remote object identification and characterization, and more particularly to sensors for identification and characterization using electrostatic charging and electric potential changes.

Characterization of remote hidden objects may be performed using ultrasonic, eddy current, x-ray radiography, thermal, neutron radiography, terahertz imaging, and microwave based technologies. These inspection technologies work well when there are voids, inclusions, disbonds, cracks, or large changes in density or dielectric properties of the hidden object. However, these inspection technologies generally fail to be adequate when there are subtle changes in dielectric or electric properties of a hidden object, materials of a hidden object and the surrounding structure hiding the hidden object are of similar densities, very thin materials make up the hidden object, and for complex or hybrid structures hiding a hidden object.

### SUMMARY

One or more embodiments of the present disclosure provide systems and methods to dynamically create and annihilate subsurface electric dipoles having variable strength and variable alignment. The ability of various embodiments to create, annihilate, and control subsurface dipoles may be a useful technology for wide variety of applications including the nondestructive testing of materials and structures, for generating and receiving directed and omni-directional variable amplitude and frequency transmission waves without the need for conductive antennas, for phonon to electromagnetic power conversion, for materials and manufacturing process control, atomic and nanoparticle alignment, and for control and utilization as medical therapies.

2

One or more embodiments of the present disclosure may provide systems and methods for characterizing objects, including a phonon generation source, and an imaging array, such as an electric potential imaging array or an electric field imaging array, wherein the phonon generation source is configured to propagate phonons into an object comprising two materials while the imaging array generates one or more electric potential images of the object from which electric field components may be determined and imaged.

These and other aspects of the present disclosure will be further understood and appreciated by those skilled in the art by reference to the following specification, claims, and appended drawings.

### BRIEF DESCRIPTION OF THE DRAWINGS

FIG. 1A is a block diagram illustrating triboelectric charging of dissimilar materials, consistent with one or more embodiments of the present disclosure.

FIG. 1B is a block diagram showing the electric charges of a created dipole of FIG. 1A, consistent with one or more embodiments of the present disclosure.

FIG. 2 is a graph of dipole field orthogonal components, consistent with one or more embodiments of the present disclosure.

FIG. 3A illustrates an embodiment system for phonon assisted creation and annihilation of variable strength and variable alignment subsurface electric dipoles, consistent with one or more embodiments of the present disclosure.

FIG. 3B is a graph of an electric potential waveform at a point, consistent with one or more embodiments of the present disclosure.

FIGS. 4, 5, and 6 illustrate example electric dipole fields that may be generated according to one or more embodiments of the present disclosure.

FIG. 7 illustrates an example antenna system, consistent with one or more embodiments of the present disclosure.

### DETAILED DESCRIPTION

Aspects of the present disclosure address challenges including those discussed above, and may be applicable to a variety of applications, devices, systems, and methods for identifying and characterizing hidden objects. These and other aspects of the present disclosure are exemplified in a number of implementations and applications, some of which are shown in the figures and characterized in the claims section that follows. It should be noted that the figures may not be drawn to scale and that the elements of similar structures or functions are represented by like reference numerals throughout the figures. It should be noted that the figures are only intended to facilitate the description of the features. They are not intended as an exhaustive description of the disclosed embodiments or as a limitation on the scope of the claimed invention. In addition, a disclosed embodiment need not have all the aspects or advantages shown or described herein. An aspect or an advantage described in conjunction with a particular embodiment is not necessarily limited to that embodiment and can be practiced in any other embodiments even if not so illustrated.

Some inspection technologies, such as ultrasonic, eddy current, x-ray radiography, thermal, neutron radiography, terahertz imaging, and microwave based inspection technologies, may not be sensitive to triboelectric properties.

The electric potential and field emanating from subsurface triboelectrically charged objects maybe quantitatively characterized and imaged, for example, using physical contact

with objects of interest or by charge injection to characterize subsurface materials. The various embodiments extend electric potential and field quantitative characterization and imaging to provide the capability to remotely dynamically create and annihilate subsurface electric dipoles having variable strength and variable alignment. The various embodiments may allow for interrogation of subsurface bonded components and determination of the quantitative degree of bonding. The ability to create, annihilate, and control subsurface dipoles may be a useful technology for wide variety of applications. Some example applications include, the nondestructive testing of materials and structures, tagging of subsurface material components, for generating and receiving directed and omni-directional variable amplitude and frequency transmission waves without the need for conductive antennas, phonon to electromagnetic power conversion, materials and manufacturing process control, atomic and nanoparticle alignment, and control and utilization as medical therapy. One or more embodiments may generate variable strength subsurface electric dipoles using phonon excitation. Some various applications of the one or more embodiments generate variable strength subsurface electric dipoles using phonon excitation and may include as an inspection method and/or may be applied for use as a therapeutic technology.

Electric dipoles may be used by transmission antenna systems and electric microphones. There has been limited work trying to control electric dipoles affecting the build-up of nano-structures in electronic systems. However, these activities do not address the concept of generating dipoles in place or in an ephemeral manner. One or more embodiments provide a method of generating or creating dipoles in regions of interest for a specified purpose and then these dipoles are annihilated by the host material. One of more embodiments may also provide a method for generating the dipoles based on phonon-surface potential interactions leveraging the triboelectric affinity of materials. In some embodiments, observation and control of the created dipoles allow dipole field to be measured and made visible using electric potential and/or electric field imaging technology. By varying the amplitude of the phonon the subsurface bonded, partially bonded, and/or, in contact but not necessarily bonded, systems are uniquely and quantitatively characterized for bonding potentials.

The various embodiments may be useful for wide variety of applications including, for example, nondestructive testing of materials and structures, for generating and receiving directed and omni-directional variable amplitude and frequency transmission waves without the need for conductive antennas and having dimension several orders of magnitude smaller than existing antennas, for phonon to electromagnetic power conversion, for materials and manufacturing process control, for control of atomic and nanoparticle alignment in nanosystems, for control and utilization as medical therapy, and/or for quantitatively characterizing subsurface bonding potentials in complex materials.

FIG. 1A is a block diagram illustrating triboelectric charging of dissimilar materials **101** and **102**. When two surfaces **101s** and **102s** of dissimilar materials, **101** and **102** respectively, come into momentary contact or near contact to produce an interface **106**, electric charges or free carriers are exchanged so that surface **101s** of material **100** takes on an electrical charge and the surface **102s** of material **102** takes on an opposite charge. The degree to which materials take on an electrical charge is identified by the triboelectric affinity of the materials in momentary contact. This process is

commonly referred to triboelectric charging. Triboelectric charging is a major contributor to electrostatic discharge.

While illustrated as solid dissimilar materials **101** and **102** in momentary contact or near contact, the materials **101** and **102** may have other characteristics. For example, the surfaces **101s** and **102s** need not be solid. As another example, the time in contact or near contact may not be momentary. As further examples, materials **101** and **102** and their surfaces may not be dissimilar and that interface **106** may be established even when material **101** and **102** are originally identical. As another example, material **101** and material **102** may be the same bulk material where a separation interface **106** is created, for example as fatigue crack or other interface **106**, between the two materials **101** and **102** at some time.

After triboelectric charging, for example, a positive charge **103** is on the surface **101s** of material **101** and at a distance  $\Delta Z_p$  from the surface **102s** and a negative charge **104** is on the surface **102s** of material **102**. The distance  $\Delta Z_p$  is often macroscopic, for example, as one demonstrates triboelectric charging by rubbing a glass rod with a silk cloth. When looked closely at the triboelectric process, and at very small distance  $\Delta Z_p$  being of atomic dimensions, an electric dipole **107** is created with an electric field strength (dipole moment) that is proportional to the charge “q” (charges **103** or **104**) and distance  $\Delta Z_p$ . The electric charges **103** and **104** of a created dipole **107** are graphically shown in FIG. 1B with the dipole electric field lines shown over the materials **101** and **102**. Although only one dipole **107** is graphically shown many dipoles may exist simultaneously. By varying the distance, or the charge “q”, the electric field strength of the dipole **107** is varied. For slowly varying distance  $\Delta Z_p$ , the electric field of the dipole **107** is electrostatic or quasi-static. For rapidly varying distance  $\Delta Z_p$ , the electric field of the dipole **107** is electrodynamic. When the distance  $\Delta Z_p$  goes to zero, the dipole **107** may be annihilated as the charges return to their host materials **101** and **102**. The electric potential and electric field emanating from a dipole **107** is a function of distance and angular orientation. Referring to FIG. 2, the dipole field orthogonal components at any point at the distance vector  $\vec{r}$ , are given by:

$$E_r = \frac{2p\cos(\theta)}{4\pi\epsilon_0 r^3}$$

$$E_\theta = \frac{p\sin(\theta)}{4\pi\epsilon_0 r^3}$$

$$E_\phi = 0$$

where p is the magnitude of the electric dipole moment,  $p=q\Delta Z_p$  and  $r=|\vec{r}|$ .

Referring back to FIG. 1A, the designation  $\Delta Z_p$  is used to denote atomic distances generated by phonon **108**. For both macroscopic and atomic distances  $\Delta Z_p$ , dipoles **107** are created. However, other charge distributions generated may also contain other higher moments including a dipole moment, such as quadrupole, octupole, etc., due to the complex shape and charge distribution on macroscopic objects **101** and **102** and their respective surfaces. In some embodiments, other higher moments may be produced simultaneously by phonons creating dipoles. In some embodiments, the interface **106** may not be a free surface where the distortion of the electron clouds of the constitutive atoms at the interface **106** generates electric dipole and higher moment fields.

## 5

The distance  $\Delta Z_P$  shown in FIG. 1B is generally considered to be macroscopic for triboelectric charging as macroscopic distances are used to reveal the resulting electrically charged surfaces of dissimilar materials. In contrast, much smaller distances  $\Delta Z_P$ , that may be atomic in length and at surface and subsurface locations, may be dynamically changed by phonons **108** to create and annihilate and control properties of electrical dipoles **107** by changing  $\Delta Z_P$ . Referring to FIGS. 1A and 1B, and as an example, if the subsurface distance  $\Delta Z_P$  at the interface of material **101** and material **102** is made non-zero, then triboelectric charging will create local electric dipoles **107** that are internal and on sub-surfaces **101s** and **102s**. If the interface of material **101** and material **102** is already non-zero, and an electric dipole **107** is already present, then the distance  $\Delta Z_P$  between interface of material **101** and material **102** may be changed to vary the dipole strength and alignment.

Phonons **108** may be used to vary the distance  $\Delta Z_P$  from zero to a non-zero value as shown in FIG. 1A. FIG. 3A illustrates an embodiment system for phonon assisted creation and annihilation of variable strength and variable alignment subsurface electric dipoles. The phonons **108** may be generated external to the surface of an object **312** including material **101** and material **102**. The phonons **108** may be generated by phonon source **310** that may be a non-contact device, for example, an air coupled ultrasonic transducer, sound speaker in air, etc., or a contact device may be used such as ultrasonic transducer or mechanical vibration system in contact with the object **312** including material **101** and material **102**. The phonon source **310** may be a movable scanning source.

An electric potential and electric field measurement system in a two dimensional array configuration may be used to measure the electric potential and electric field external to objects in real-time. Measurements may be made without phonon excitation and with phonons present. FIG. 3A shows an example configuration of a two-dimensional imaging array **309**, such as a two dimensional electric potential imaging array or two dimensional electric field imaging array, placed a distance  $\Delta Z'$  from the object **312** including material **101** and material **102**, and the phonon source **310**. As an example, material **101** may be a container or wall that encloses or hides material **102**. There may be other objects in container of material **101** or object **312**. The phonon source **310** may or may not be in physical contact with material **101**. The phonon source **310** may be inside material **101**. The phonon source **310** may be remote from material **101**. Other objects with interfaces between or within them may be present in a container of material **101**.

Referring to FIG. 3A, as an example, measurement of the electric potential with and without phonon excitation may be made remotely, by use of imaging array **309** placed a distance  $\Delta Z'$  from material **101**. The imaging array **309** may be any type imaging array, such as a single element measurement array or multi-element imaging array, and any type imaging array **309** may also be used to make measurements. As examples, the array design and acquisition and data analyses employed by the imaging array **309** may be performed according to the methods described in U.S. Published Patent Application No. 2012/0199755, U.S. Published Patent Application No. 2015/0137825, and U.S. patent application Ser. No. 15/177,798 filed Jun. 9, 2016, which are hereby incorporated by reference herein in their entirety for all purposes. In some embodiments, the imaging array **309** may be an electric potential imaging array. Additionally or alternatively, in some embodiments, the imaging array **309** may be an electric field imaging array. At time  $\tau > 0.0$ , the

## 6

phonon source **310** may generate phonons **108** having a frequency  $\nu$  (wavelength  $k$ ) or a distribution of frequencies or wavelengths in material **101**. The phonons **108** may propagate into other adjacent materials. The electric potential at a time  $\tau > 0.0$  is measured by the array **309** at a distance  $\Delta Z'$  from the surface and parallel to the surface of material **101**. The electric potential image **311** at the array **309** position may be generated and displayed on a monitor. From the electric potential measured by the imaging array **309**, the electric field components may be determined and imaged. Any method may be used for determining electric field components from electric potential data, such as by differencing electric potentials as described in U.S. patent application Ser. No. 15/637,673, titled DYNAMIC MULTIDIMENSIONAL ELECTRIC POTENTIAL AND ELECTRIC FIELD QUANTITATIVE MEASUREMENT SYSTEM AND METHOD, and filed Jun. 29, 2017, which is incorporated by reference herein in its entirety for all purposes. If electric potential data is taken at one  $\Delta Z'$  distance from material **101**, the electric field X and Y components may be determined everywhere at any point in the plane of the array **309**. If electric potential data is taken at two different  $\Delta Z'$  distances from material **101**, the electric field X, Y, and Z components may be determined everywhere at any point in the plane of the array **309**. While a parallel arrangement is illustrated in FIG. 3A, other non-parallel type arrangements may be substituted for such a parallel arrangement in one or more embodiments.

An optical image **102a** of material **102**, for example a three dimensional (3D) printed acrylonitrile butadiene styrene (ABS) polymer gun, as viewed from the position of the array **309** along the  $\Delta Z$  axis toward material **101** is shown for comparison and as a demonstration of the electric potential imaging enabled by the various embodiments. The electric potential of dipoles **311A** created at the subsurface interface **106** by the phonons **108** is measured as a function of time. FIG. 3A shows a linear grayscale representation of the electrical potential in image **311** measured a time  $\tau_1 > 0.0$ , where the dark shade represents high potential and lightest shade represents low potential. A typical electric potential waveform at a point "A" at time  $\tau = 0.0$ , when a phonon is not present is shown in FIG. 3B. A typical electrical potential waveform at a point A at time  $\tau_1 > 0.0$ , when a phonon having a frequency of 180 Hz is present, is also shown in FIG. 3B. The low potential of the oscillating waveform in FIG. 3B corresponds to the lighter shaded region at point A of the electrical potential image **311** shown in FIG. 3A. The electric potential from the created dipole oscillates in potential as long as the phonon is present, and the dipole oscillation in potential is at the phonon frequency. The amplitude and phase of the potential oscillations and the dipole moment vector may be adjusted, for example, by selection of materials supporting the phonon, the surface topologies, the phonon polarization, the phonon amplitude, or a combination thereof. In various embodiments, the electric potential measurements as a function of time maybe used to generate a video for enhanced characterization of objects. The electric potential measurement may also include higher order electric potential moments. The measurement acquisition times may be in synchronization with the phonon frequency to produce apparent still images of the electric potential at a different position distance  $\Delta Z'$ .  $\Delta Z'$  may be varied to measure the electric potential at  $\Delta Z'_1$  providing sufficient measurement information to determine the electric field vector everywhere over the plane of the array and at the position  $\Delta Z'$  due to the dipole field emanating from interface **106**.

The phonon frequency may extend from infrasonic, subsonic through acoustic to ultrasonic, and extends to optical frequencies. At low frequencies (e.g., mechanical vibrations) dipoles are created, modulate in strength, and are annihilated at static and quasi-static frequencies. At higher frequencies (e.g., ultrasonic frequencies) dipoles are created, modulate in strength, are annihilated at electrodynamic frequencies and the electric potential is measurable. The phonon frequency does not need to be repetitive and partial cycles may be used.

In one or more embodiments, the phonon frequency may be adjusted for specific applications, for example, so that non-conductive materials **101** and **102** have periodic and momentary contact during phonon excitation. FIG. 4 shows the asymmetric surface displacement  $\Delta Z_p$  for a phonon creating an arrayed electric dipole **107** field that is ephemeral and exists only when the phonons are present. FIG. 5 shows the symmetric surface displacement  $\Delta Z_p$  for phonons creating an arrayed electric dipole **107** field with distributed orientation that is ephemeral and exists only when the phonons are present. The dipole **107** orientation may also be controlled by topology of the phonon distorted or designed surfaces as shown in FIG. 5. The phonons may be polarized and with longitudinal and shear displacements allowing a wide variation in control of the displacement  $\Delta Z_p$ . FIG. 6 shows the displacement in the direction D along the X direction for a shearing phonon generating dipoles **107** along the interface **106**.

In various embodiments, the electric field from an ephemeral array may be used to transmit electrodynamic waves in a preferred direction or specified directivity. A unique advantage of using an ephemeral generated dipole array for transmission may be that for the same frequency of transmission, the phonon frequency, for example, and with polymer materials **101** and **102**, the length of the dipole array generated may be reduced by a ratio of the phonon to metal wire transmission velocities. A transmission polymer phonon based dipole array may be about  $10^{-5}$  smaller than that required for equivalent wavelength conventional metallic transmission systems.

In various embodiments, there may be more than two dissimilar surfaces and more than two dissimilar materials so that three dimensional arrays of dipoles may be constructed. The interface between surfaces **101s** and **102s** does not need to be flat and parallel and complex interface topologies may be used to enhance dipole strength and direction and periodicity in various embodiments. The surfaces **101s** and **102s** may be material graded at atomic dimensions and in depth and along the surfaces exhibit local variations in triboelectric affinity. In various embodiments, the surfaces **101s** and **102s** may be electrically conductive and have a non-zero triboelectric affinity.

In some embodiments, phonons may be generated using multiple methods to create movement between surfaces **101s** and **102s** to produce electrical dipoles and higher moments within a material or at material interface surfaces. In some implementations, more than one phonon generating method may be used simultaneously.

The generation of electric dipoles in bulk material may not be triboelectric favored due to the lack of a free surface, however, the process of creating an interface or free surface **106** in bulk materials generates topologically rough surfaces, as well as displaced atoms, thereby yielding interface **106** surfaces that are no longer electronically equivalent to the host materials **101** and **102**, and thereby creating, effec-

tively dissimilar materials surfaces **101s** and **102s** that support triboelectric charging and the creation of dipoles **107**.

In various embodiments, the phonon generated charge distribution created at surfaces **101s** and **102s** may be complex and not a pure dipole. While not a pure dipole, the electric potential and field from these more complex charge distributions may be measured and treated in a similar manner to dipoles as discussed herein.

FIG. 7 illustrates an example antenna system **700**, consistent with one or more embodiments of the present disclosure. The antenna system **700** may include components of FIG. 1B described above including two materials **101** and **102**, as well as a phonon source **310** described above with reference to FIG. 3A, all supported on an antenna frame **701**. The two materials **101** and **102** may be supported on the antenna frame **701** such that momentary contact between the materials **101** and **102** occurs, for example  $\Delta Z_p$  may be reduced to zero and then increase to a value above zero. The two materials **101** and **102** may be non-conductive antenna elements that generate and/or receive electrodynamic waves. The phonon source **310** may generate phonons directed at the materials **101** and **102**, and the generated phonons may cause the materials **101** and **102** to have momentary contact during phonon excitation. In some various embodiments, the phonon frequency may be adjusted for specific applications, for example, so that non-conductive materials **101** and **102** have periodic and momentary contact during phonon excitation. The electric potential from the created dipole oscillates in potential as long as the phonon is present, and the dipole oscillation in potential is at the phonon frequency. The amplitude and phase of the potential oscillations and the dipole moment vector may be adjusted by selection of materials supporting the phonon, the surface topologies, the phonon polarization, and the phonon amplitude. The phonons may be polarized and with longitudinal and shear displacements allowing a wide variation in control of the displacement  $\Delta Z_p$ . In various embodiments, the antenna system **700** may be an ephemeral generated dipole array and the electric field from the antenna system **700** may be used to transmit electrodynamic waves in a preferred direction or specified directivity. A unique advantage of using an ephemeral generated dipole array for transmission may be that for the same frequency of transmission, the phonon frequency, for example, and with polymer materials **101** and **102**, the length of the dipole array generated may be reduced by a ratio of the phonon to metal wire transmission velocities. A transmission polymer phonon based dipole array may be about  $10^{-5}$  smaller than that required for equivalent wavelength conventional metallic transmission systems. In one or more embodiments, the antenna system **700** may generate and/or receive directed and omni-directional variable amplitude and frequency transmission waves without the need for conductive antennas and may have a dimension several orders of magnitude smaller than existing antennas configured to generate and/or receive waves of the same amplitudes and frequencies.

It will be readily understood that the components of various embodiments of the present disclosure, as generally described and illustrated in the figures herein, may be arranged and designed in a wide variety of different configurations. Thus, the detailed description of the embodiments of the present disclosure, as represented in the attached figures, is not intended to limit the scope of the invention as claimed, but is merely representative of selected embodiments.

The features, structures, or characteristics of the present disclosure may be combined in any suitable manner in one or more embodiments. For example, reference throughout this specification to “certain embodiments,” “some embodiments,” or similar language means that a particular feature, structure, or characteristic described in connection with the embodiment is included in at least one embodiment. Thus, appearances of the phrases “in certain embodiments,” “in some embodiment,” “in other embodiments,” or similar language throughout this specification do not necessarily all refer to the same group of embodiments and the described features, structures, or characteristics may be combined in any suitable manner in one or more embodiments.

It should be noted that reference throughout this specification to features, advantages, or similar language does not imply that all of the features and advantages should be or are present in any single embodiment of the present disclosure. Rather, language referring to the features and advantages is understood to mean that a specific feature, advantage, or characteristic described in connection with an embodiment is included in at least one embodiment of the present disclosure. Thus, discussion of the features and advantages, and similar language, throughout this specification may, but do not necessarily, refer to the same embodiment. Furthermore, features, advantages, and characteristics described herein may be combined in any suitable manner in one or more embodiments. For example, although aspects and features may in some cases be described in individual figures, it will be appreciated that features from one figure can be combined with features of another figure even though the combination is not explicitly shown or explicitly described as a combination. Moreover, one skilled in the relevant art will recognize that the invention can be practiced without one or more of the specific features or advantages of a particular embodiment illustrated in the figures or described herein. In other instances, additional features and advantages may be recognized in certain embodiments that may not be present in all embodiments of the present disclosure. One having ordinary skill in the art will readily understand that the one or more embodiments as discussed herein may be practiced with steps in a different order, and/or with hardware elements in configurations which are different than those which are disclosed.

Other aspects and embodiments may will be apparent from consideration of the specification. It is intended that the specification and illustrated embodiments be considered as examples only with a true scope of the invention being indicated by the following-claims.

What is claimed is:

1. An antenna system, comprising:
  - a phonon generation source;
  - a first non-conductive antenna element; and
  - a second non-conductive antenna element,
 wherein the phonon generation source is configured to propagate phonons into the first and second non-conductive antenna elements to cause momentary contact between the first and second non-conductive antenna elements to generate or receive electrodynamic waves.
2. The antenna system of claim 1, wherein the phonon generation source is a non-contact device.
3. The antenna system of claim 2, wherein the phonon generation source is an air coupled ultrasonic transducer or sound speaker.

4. The antenna system of claim 1, wherein the phonon generation source is a contact device which is in contact with one or both of the first and second non-conductive antenna elements.

5. The antenna system of claim 4, wherein the phonon generation source is an ultrasonic transducer or mechanical vibration device.

6. The antenna system of claim 1, wherein each of the first and second non-conductive antenna elements is a bulk material.

7. The antenna system of claim 6, wherein the first and second non-conductive antenna elements are different bulk materials.

8. An antenna system, consisting of:
 

- a frame, the frame supporting,
- a phonon generation source;
- a first non-conductive material; and
- a second non-conductive material;

 wherein the phonon generation source is configured to propagate phonons into the first and second non-conductive elements to cause momentary contact between the first and second non-conductive elements to generate or receive electrodynamic waves.

9. The antenna system of claim 8, wherein the phonon generation source is a non-contact device.

10. The antenna system of claim 9, wherein the phonon generation source is an air coupled ultrasonic transducer or sound speaker.

11. The antenna system of claim 8, wherein the phonon generation source is a contact device which is in contact with one or both of the first and second non-conductive materials.

12. The antenna system of claim 11, wherein the phonon generation source is an ultrasonic transducer or mechanical vibration device.

13. The antenna system of claim 8, wherein each of the first and second non-conductive materials is a bulk material.

14. The antenna system of claim 13, wherein the first and second non-conductive materials are different bulk materials.

15. An antenna system, comprising:
 

- a phonon generation source;
- a first non-conductive element formed of a first polymer material; and
- a second non-conductive element formed of a second polymer material,

 wherein the phonon generation source is configured to propagate phonons into the first and second non-conductive elements to cause momentary contact between the first and second non-conductive elements to generate or receive electrodynamic waves.

16. The antenna system of claim 15, wherein the phonon generation source is a non-contact device.

17. The antenna system of claim 16, wherein the phonon generation source is an air coupled ultrasonic transducer or sound speaker.

18. The antenna system of claim 15, wherein the phonon generation source is a contact device which is in contact with one or both of the first and second non-conductive elements.

19. The antenna system of claim 18, wherein the phonon generation source is an ultrasonic transducer or mechanical vibration device.