



(19) **United States**

(12) **Patent Application Publication**
Chan et al.

(10) **Pub. No.: US 2024/0103301 A1**
(43) **Pub. Date: Mar. 28, 2024**

(54) **HEAD-MOUNTED DISPLAY DEVICE WITH VISION CORRECTION**

(71) Applicant: **Apple Inc.**, Cupertino, CA (US)

(72) Inventors: **Victoria C. Chan**, Sunnyvale, CA (US); **Christina G. Gambacorta**, Santa Cruz, CA (US); **Graham B. Myhre**, Campbell, CA (US); **Hyungryul Choi**, San Jose, CA (US); **Nan Zhu**, San Jose, CA (US); **Phil M. Hobson**, Menlo Park, CA (US); **William W. Sprague**, San Francisco, CA (US); **Edward A. Valko**, Morgan Hill, CA (US); **Qiong Huang**, San Mateo, CA (US); **Branko Petljanski**, Neubiberg (DE); **Paul V. Johnson**, San Francisco, CA (US); **Brandon E. Clarke**, San Jose, CA (US); **Elijah H. Kleeman**, San Jose, CA (US)

A61B 3/032 (2006.01)
A61B 3/036 (2006.01)
G02B 6/42 (2006.01)
G02B 7/02 (2006.01)
G02B 7/09 (2006.01)
G02F 1/133 (2006.01)
G06F 1/16 (2006.01)

(52) **U.S. Cl.**
CPC *G02C 7/083* (2013.01); *A61B 3/0008* (2013.01); *A61B 3/032* (2013.01); *A61B 3/036* (2013.01); *G02B 6/4204* (2013.01); *G02B 7/023* (2013.01); *G02B 7/09* (2013.01); *G02F 1/13306* (2013.01); *G06F 1/163* (2013.01); *G02F 1/13439* (2013.01)

(21) Appl. No.: **18/530,471**

(22) Filed: **Dec. 6, 2023**

Related U.S. Application Data

(63) Continuation of application No. 16/612,336, filed on Nov. 8, 2019, now Pat. No. 11,874,530, filed as application No. PCT/US18/30832 on May 3, 2018.

(60) Provisional application No. 62/507,671, filed on May 17, 2017.

Publication Classification

(51) **Int. Cl.**
G02C 7/08 (2006.01)
A61B 3/00 (2006.01)

(57) **ABSTRACT**

A head-mounted display may include a display system and an optical system in a housing. The display system may have displays that produce images. Positioners may be used to move the displays relative to the eye positions of a user's eyes. An adjustable optical system may include tunable lenses such as tunable cylindrical liquid crystal lenses. The displays may be viewed through the lenses when the user's eyes are at the eye positions. A sensor may be incorporated into the head-mounted display to measure refractive errors in the user's eyes. The sensor may include waveguides and volume holograms, and a camera for gathering light that has reflected from the retinas of the user's eyes. Viewing comfort may be enhanced by adjusting display positions relative to the eye positions and/or by adjusting lens settings based on the content being presented on the display and/or measured refractive errors.

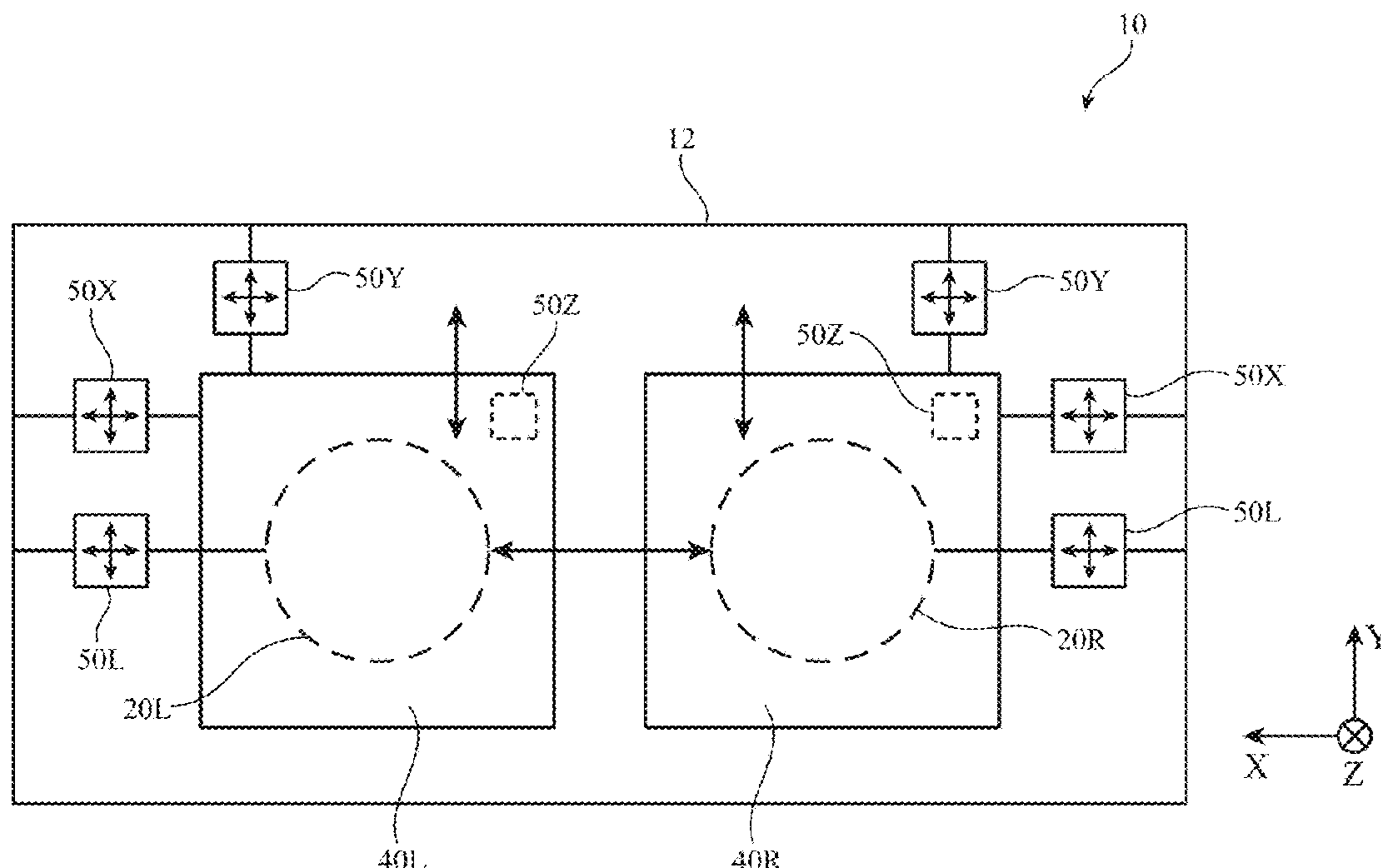

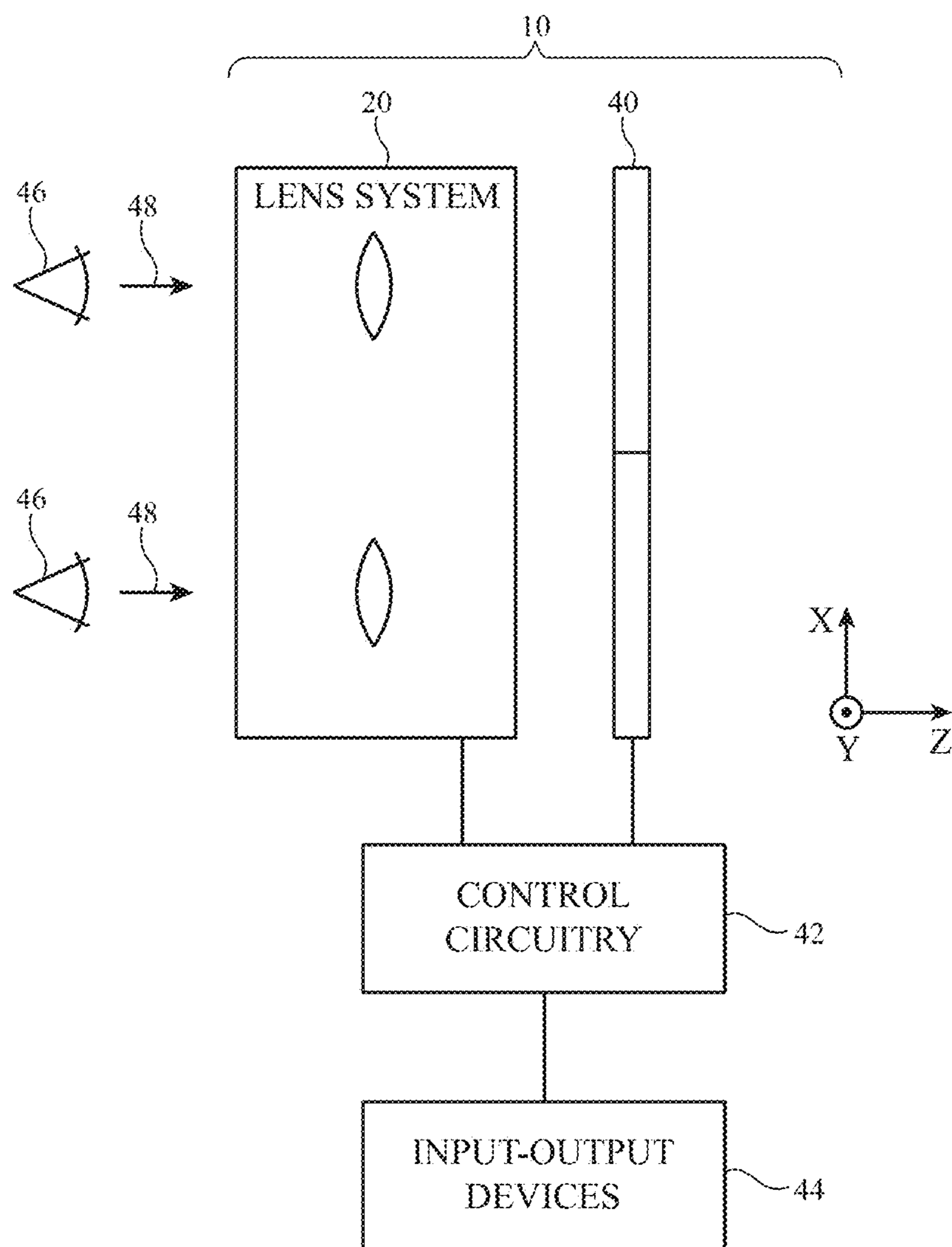

FIG. 1

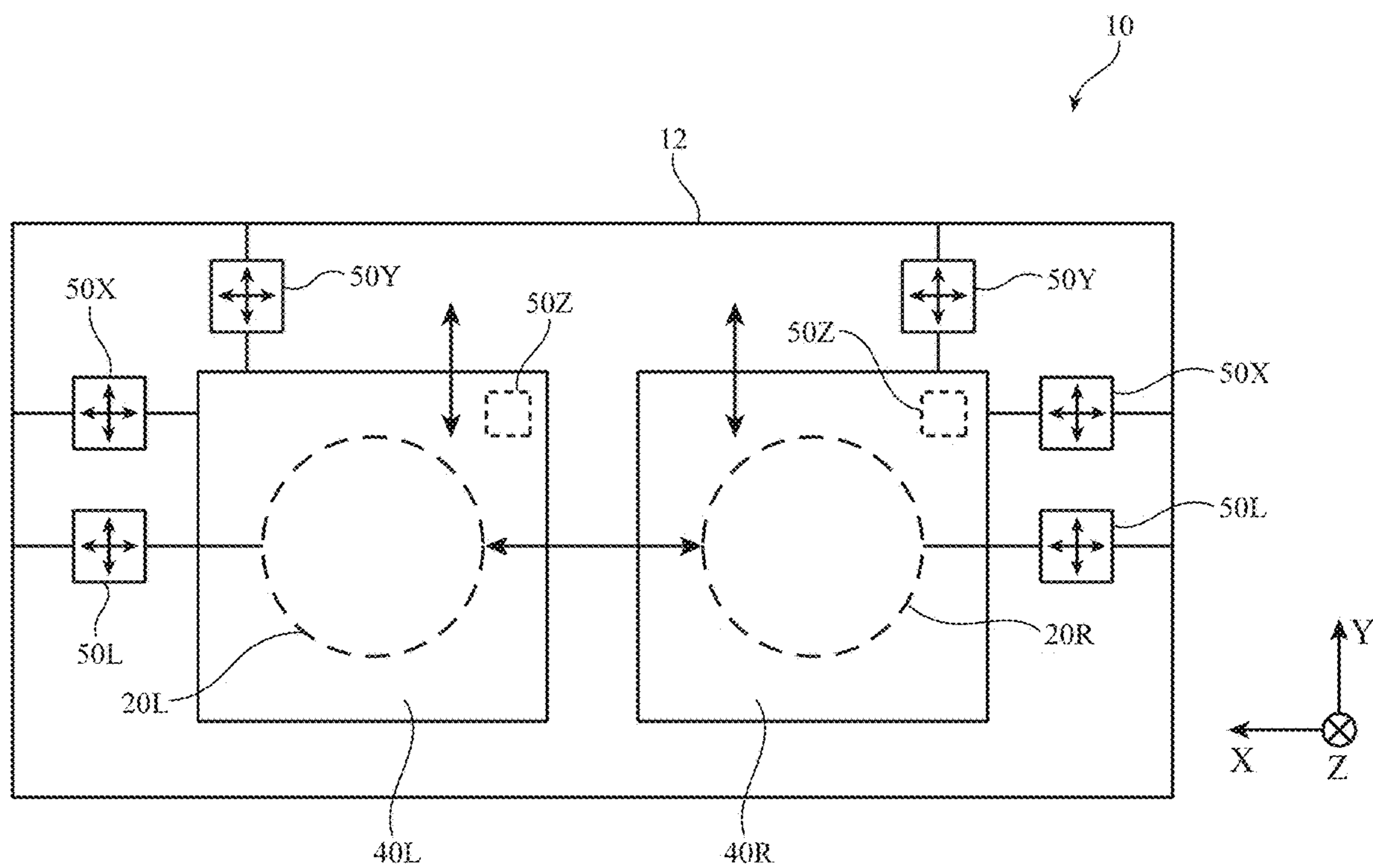

FIG. 2

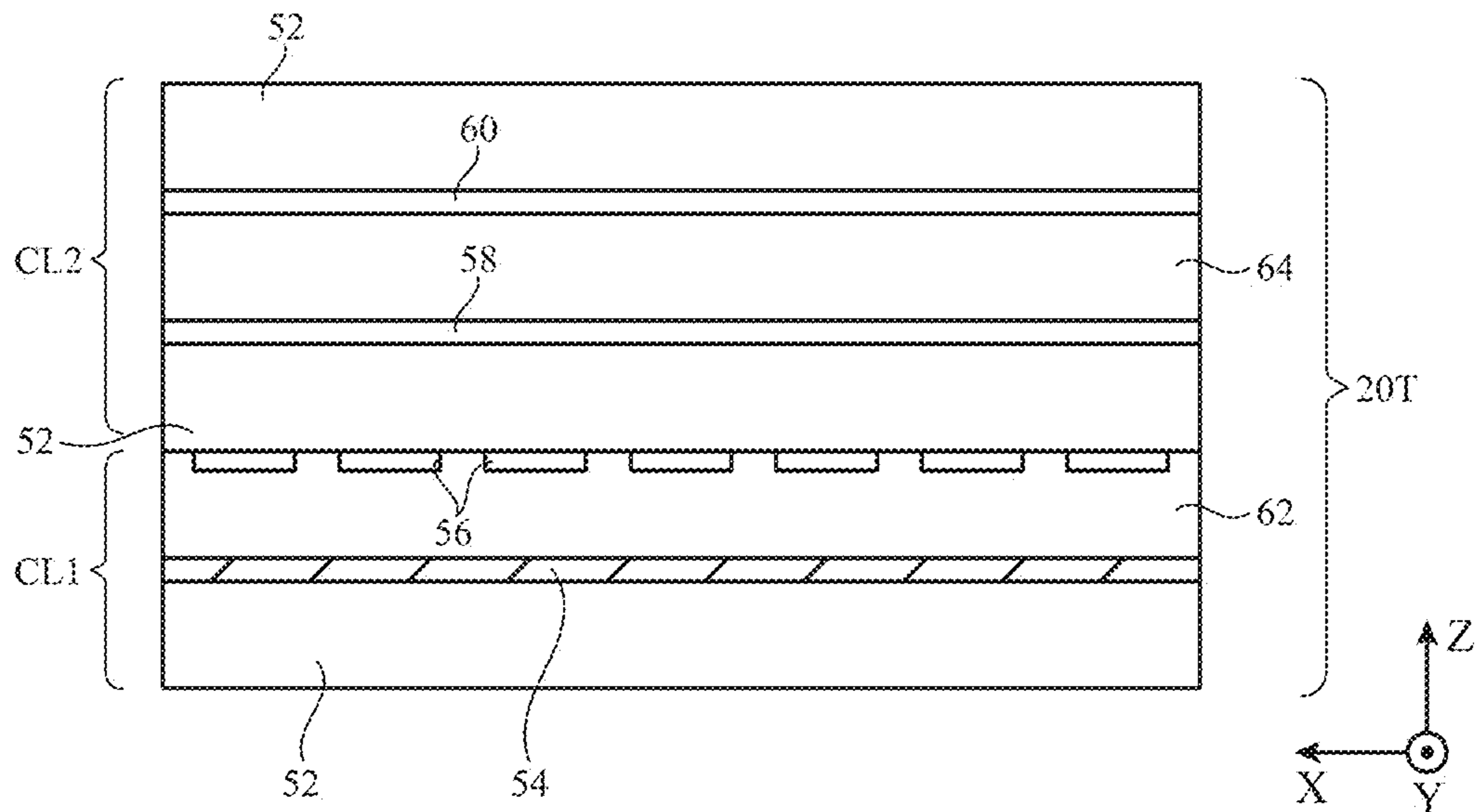

FIG. 3

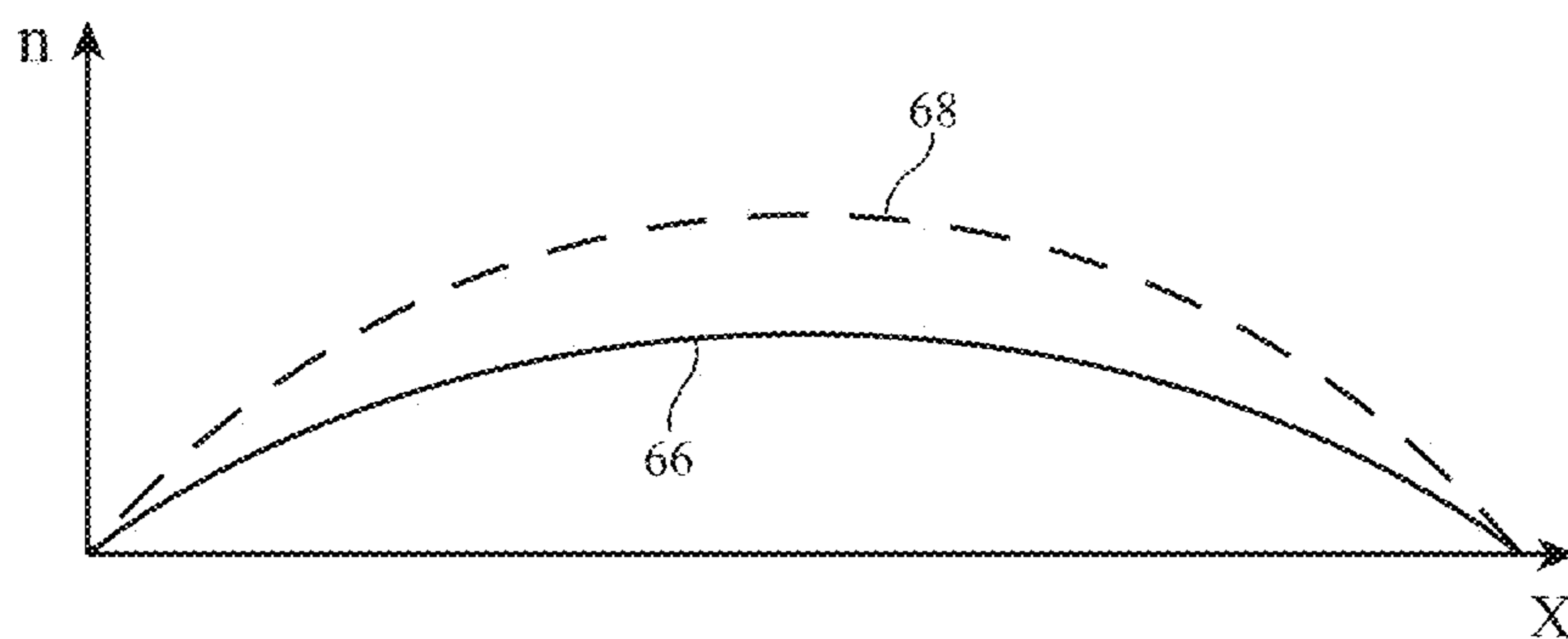

FIG. 4

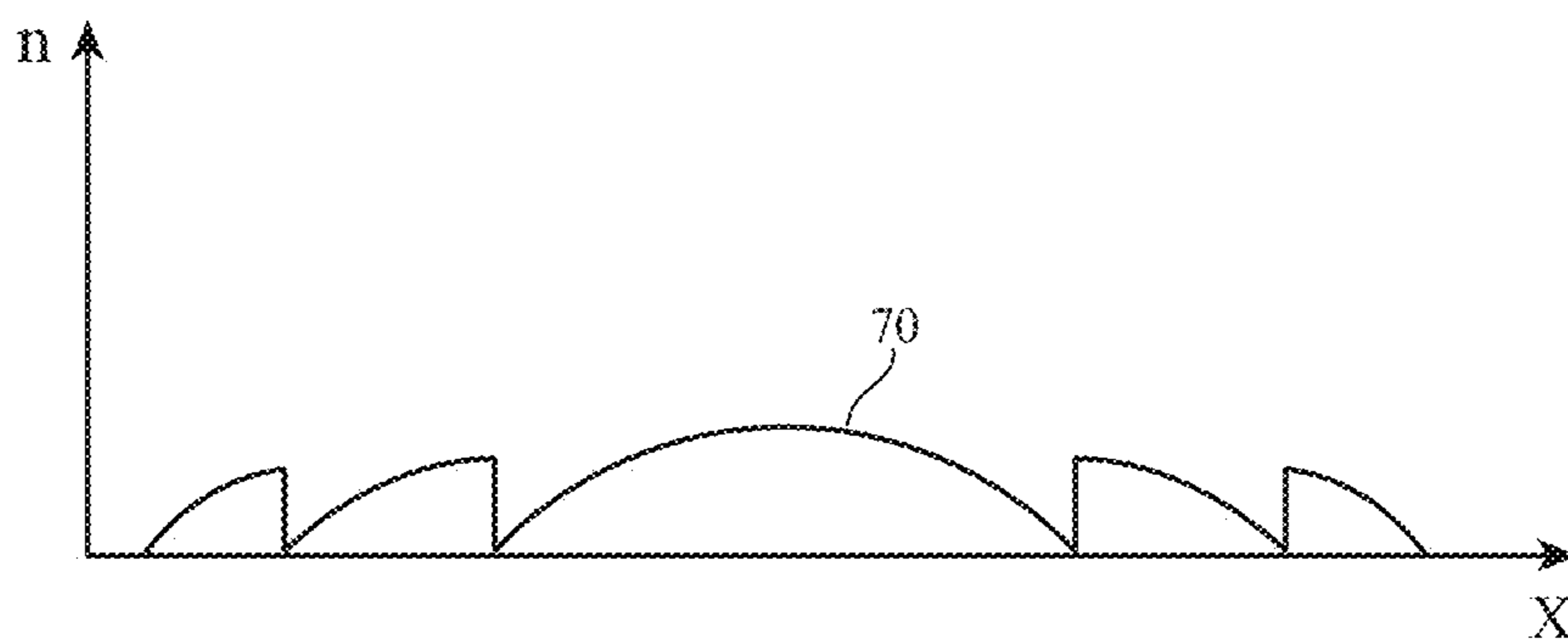

FIG. 5

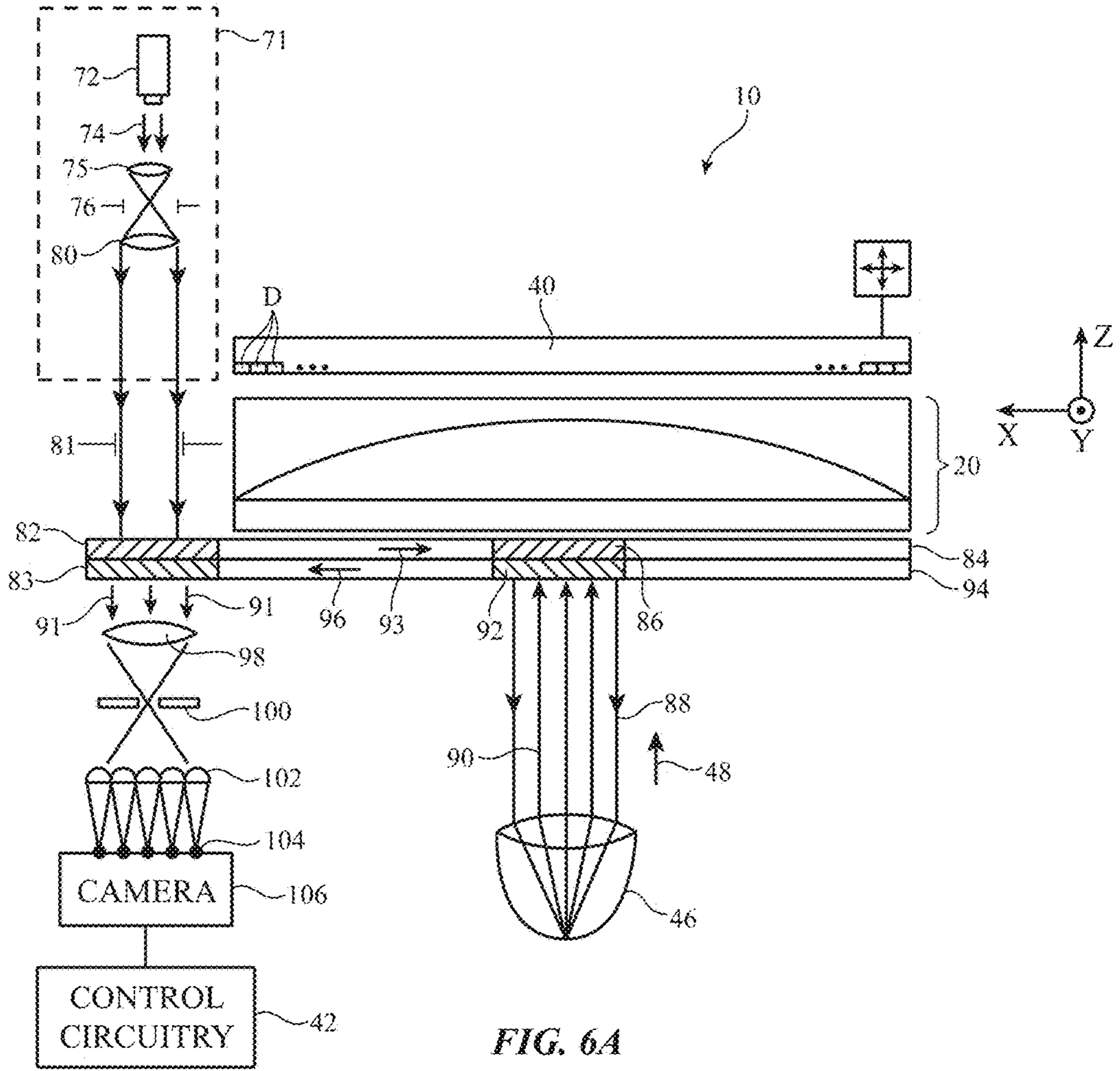

FIG. 6A

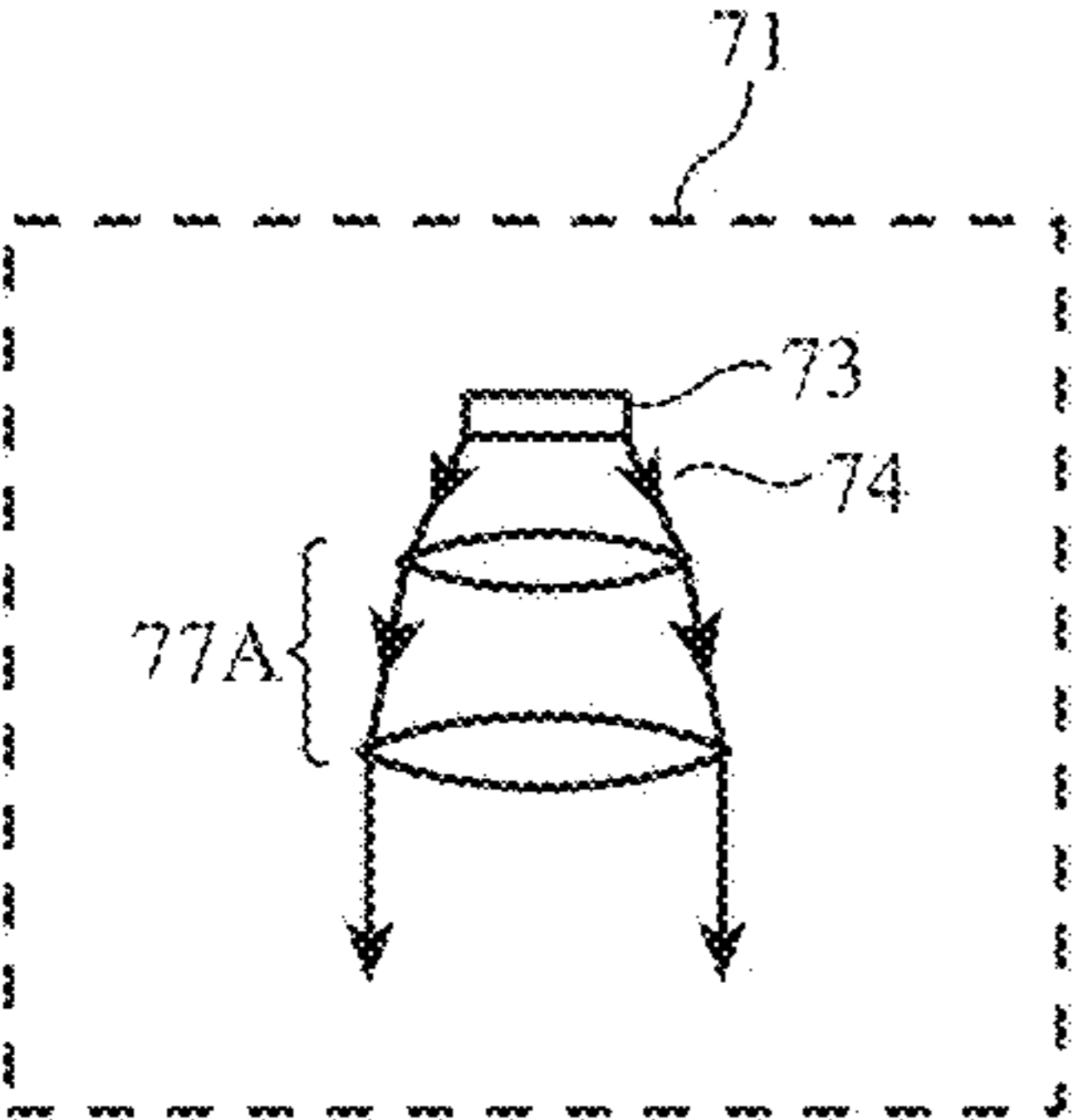

FIG. 6B

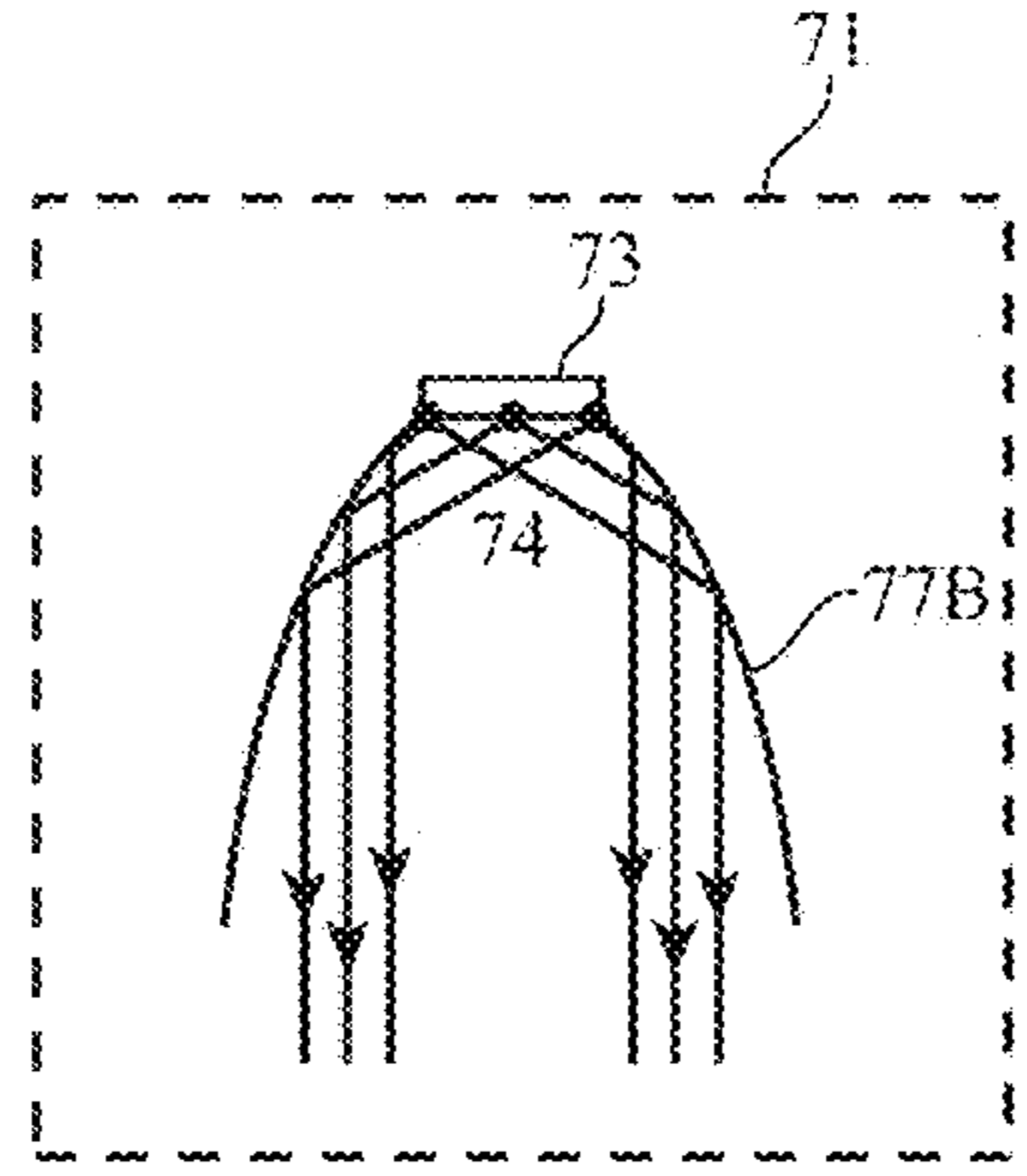

FIG. 6C

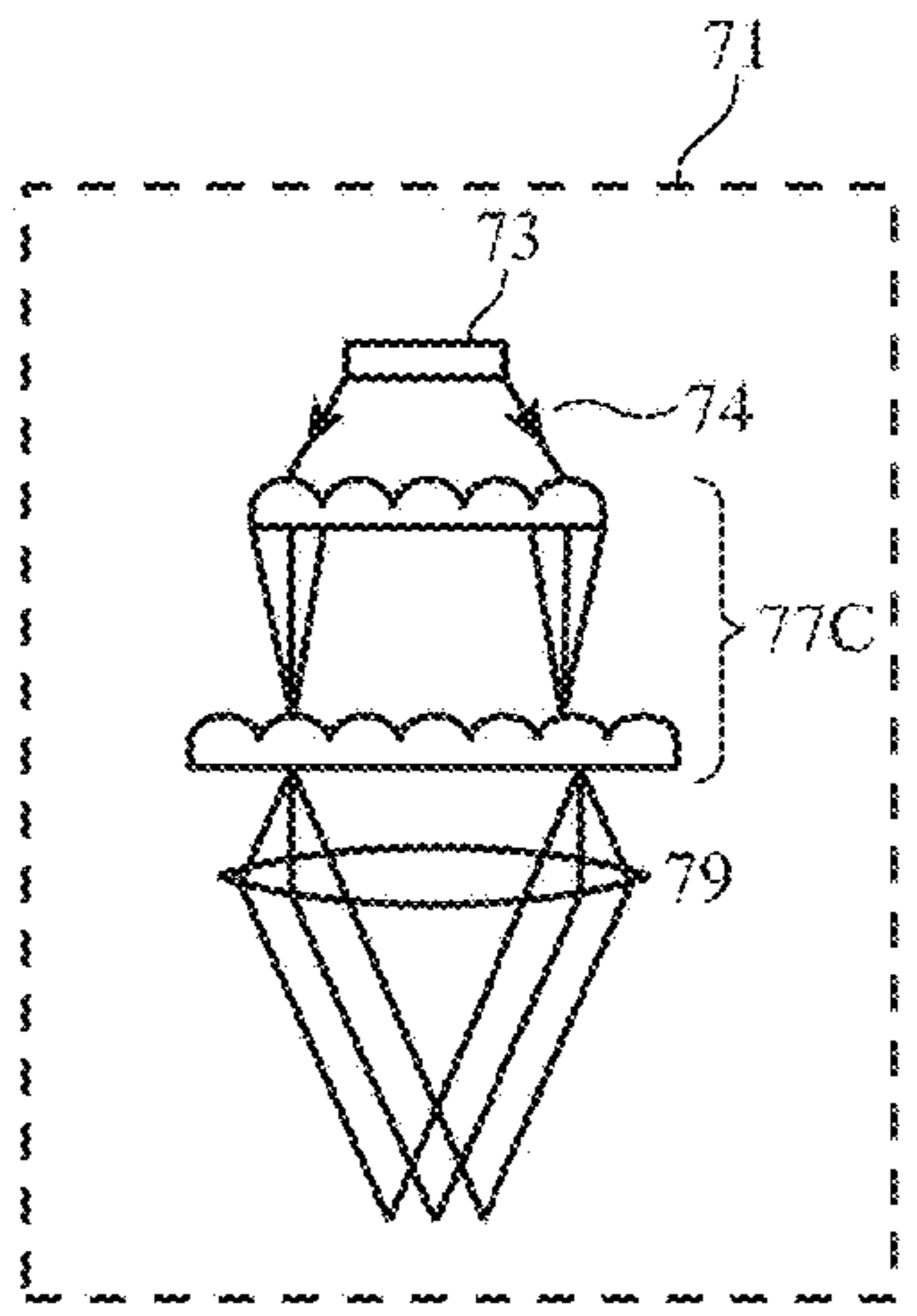

FIG. 6D

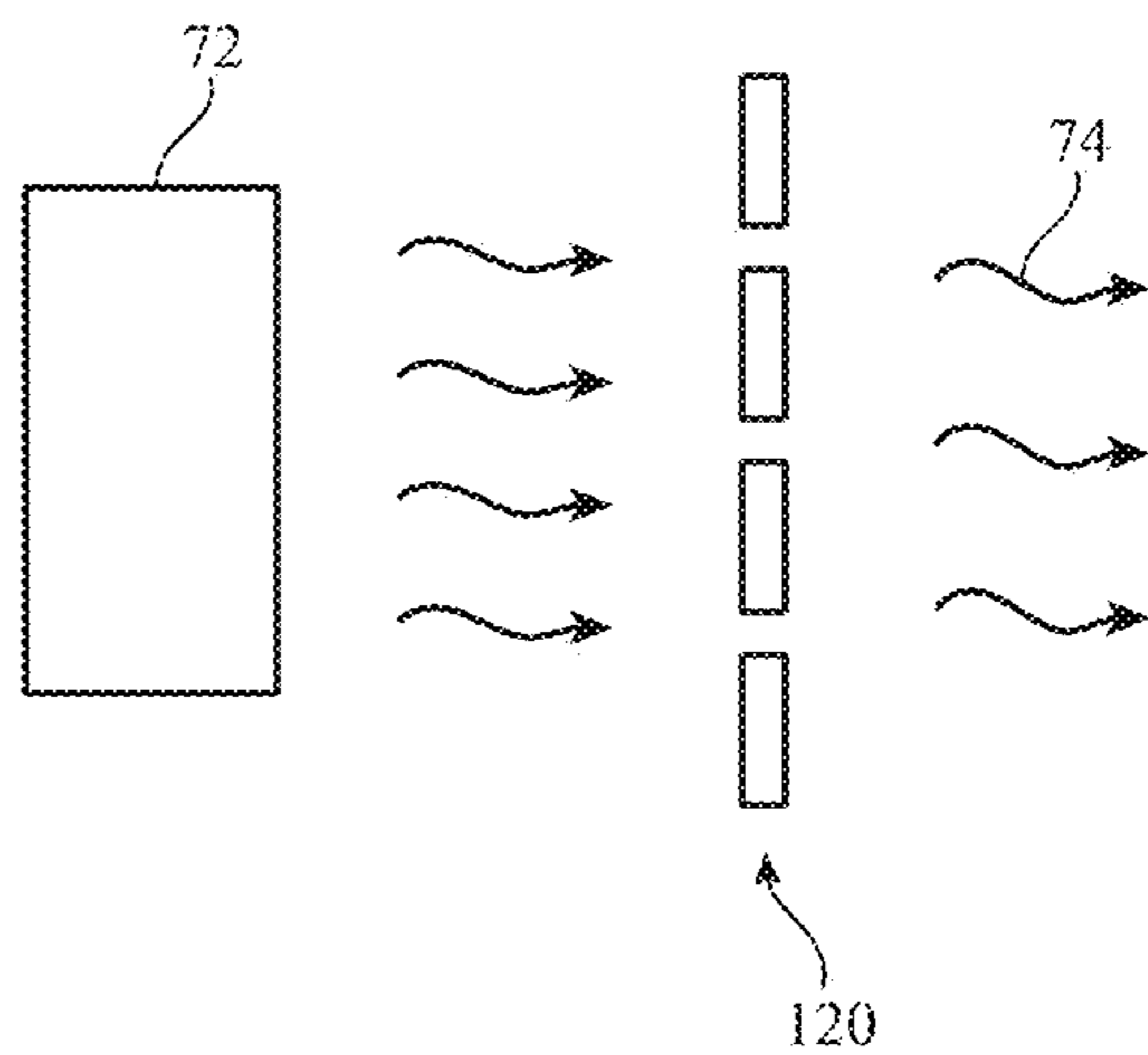

FIG. 7A

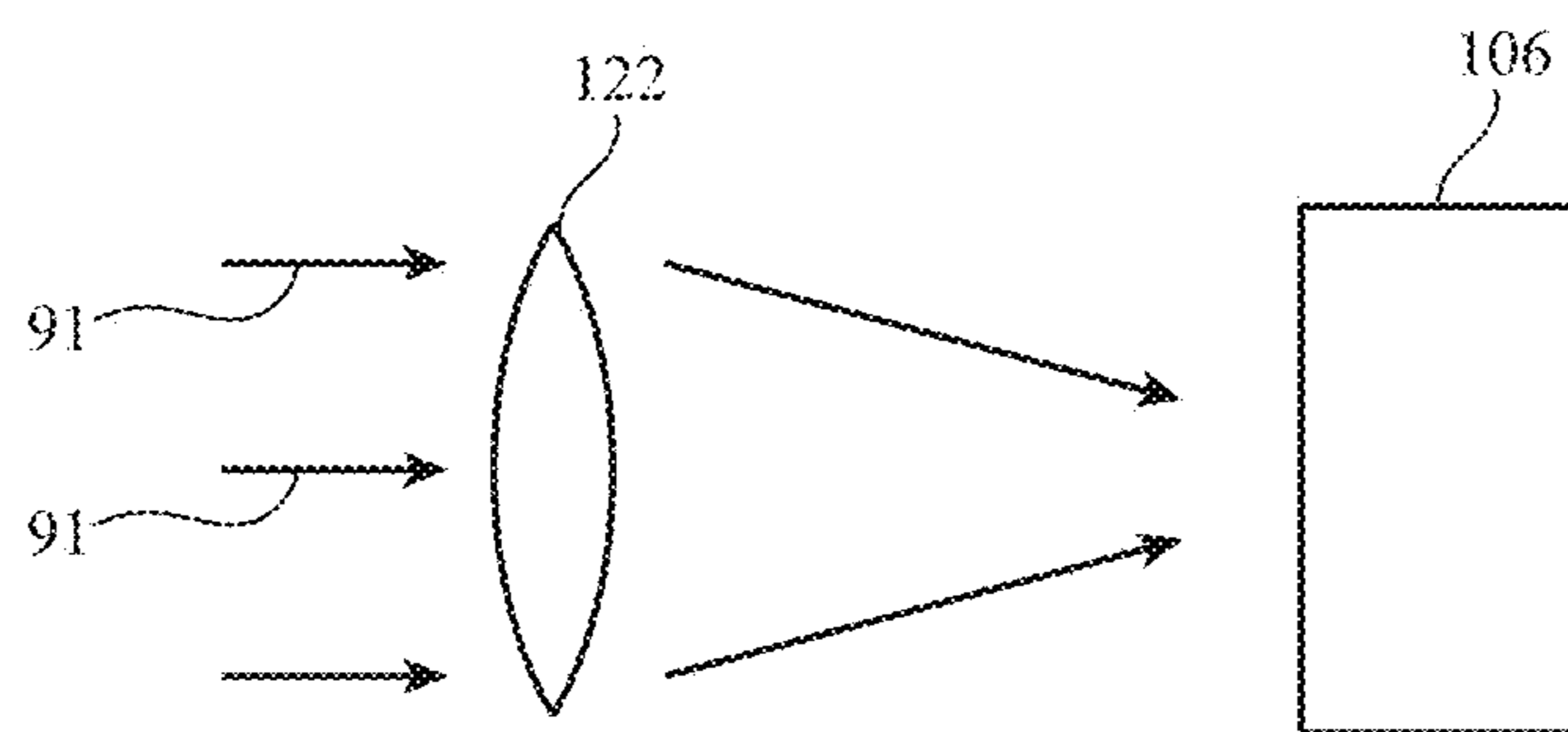

FIG. 7B

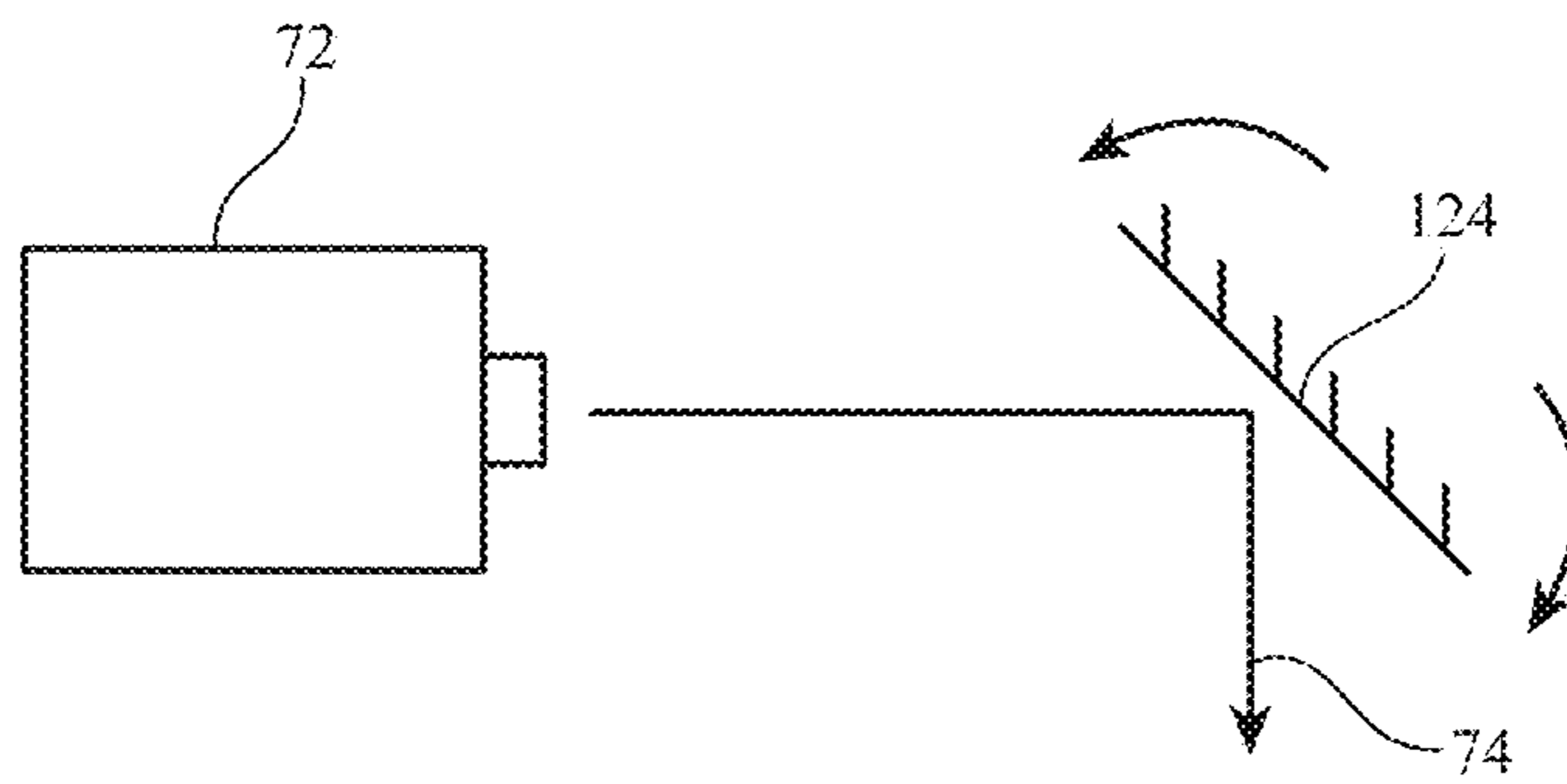

FIG. 8A

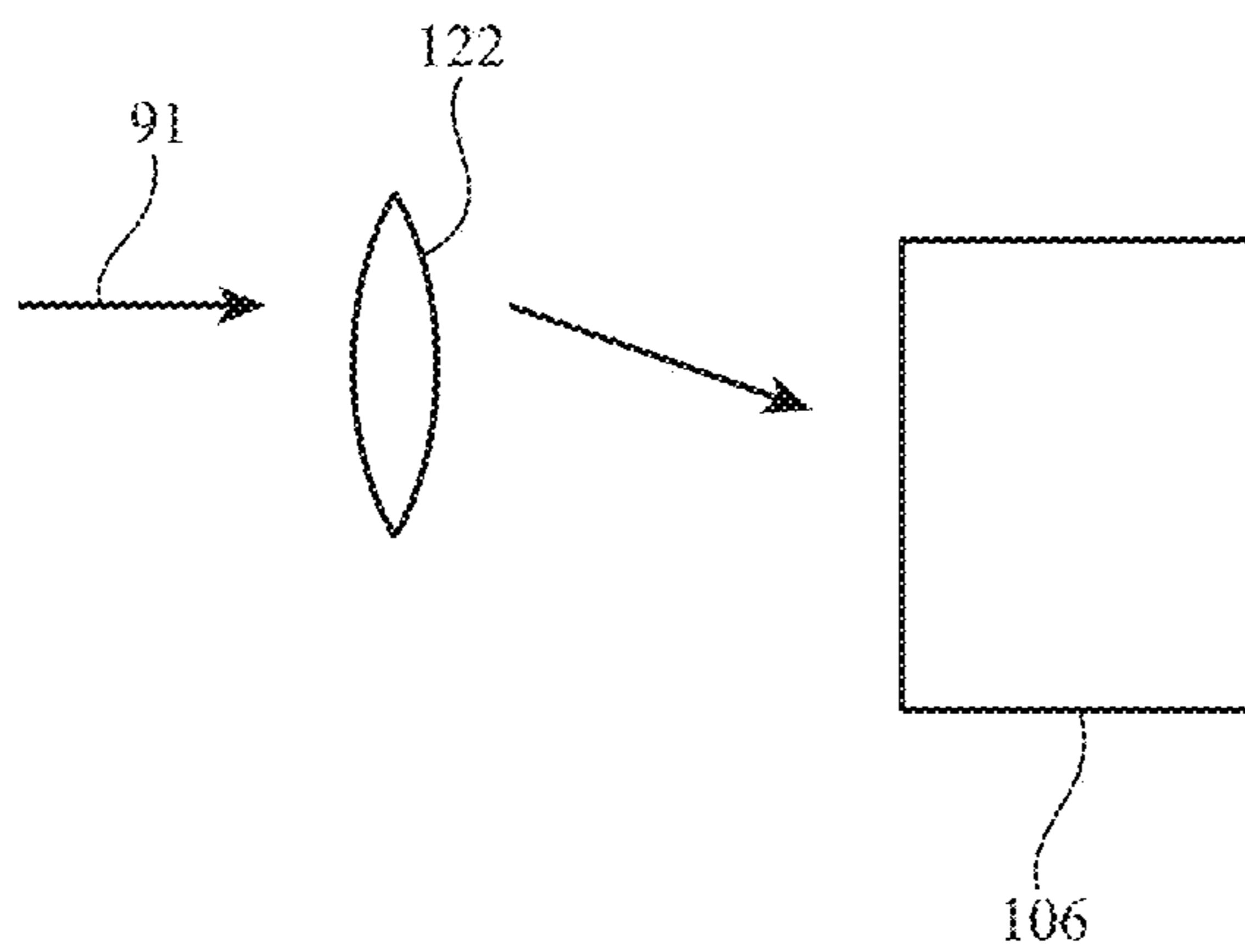

FIG. 8B

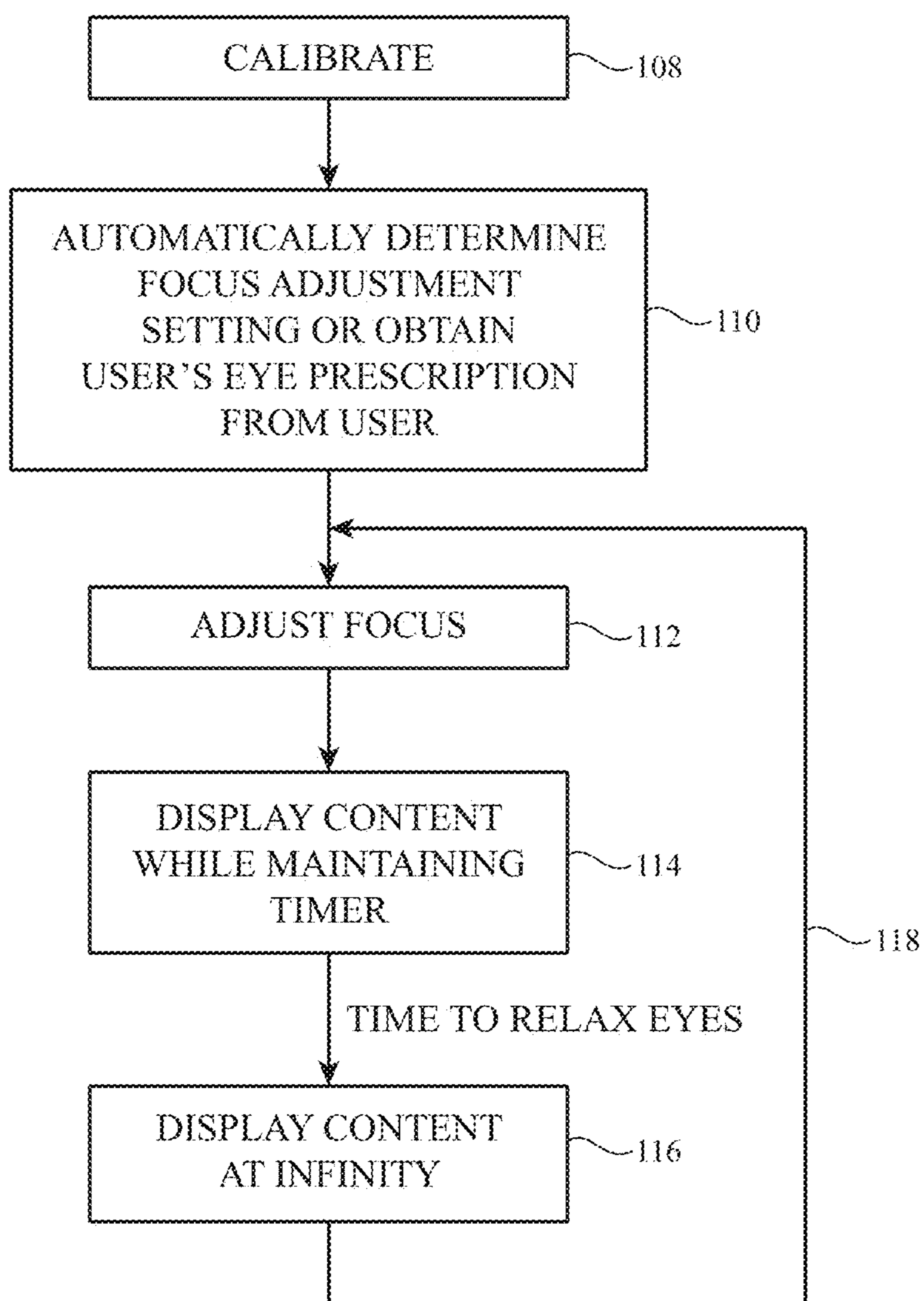

FIG. 9

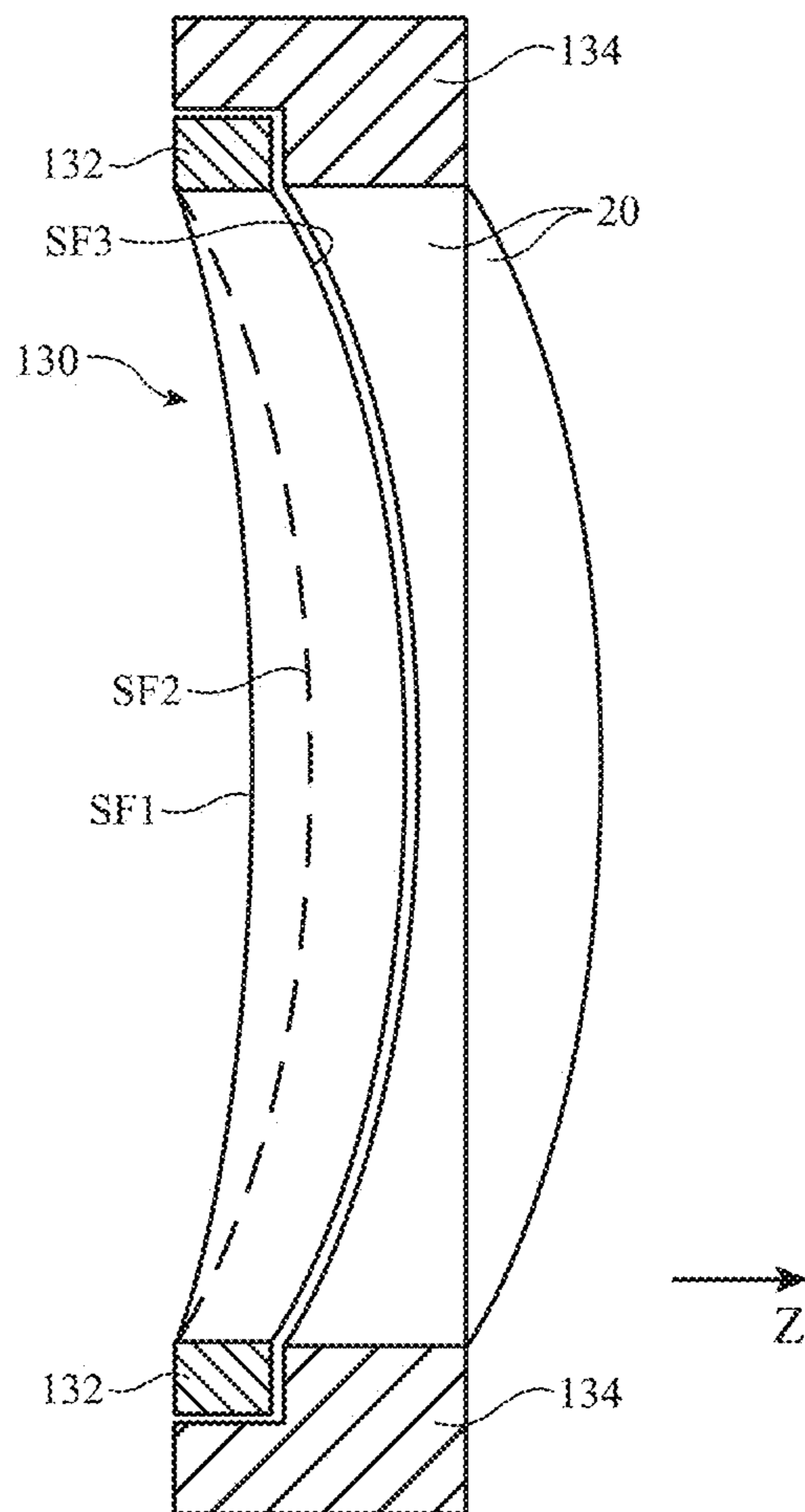

FIG. 10

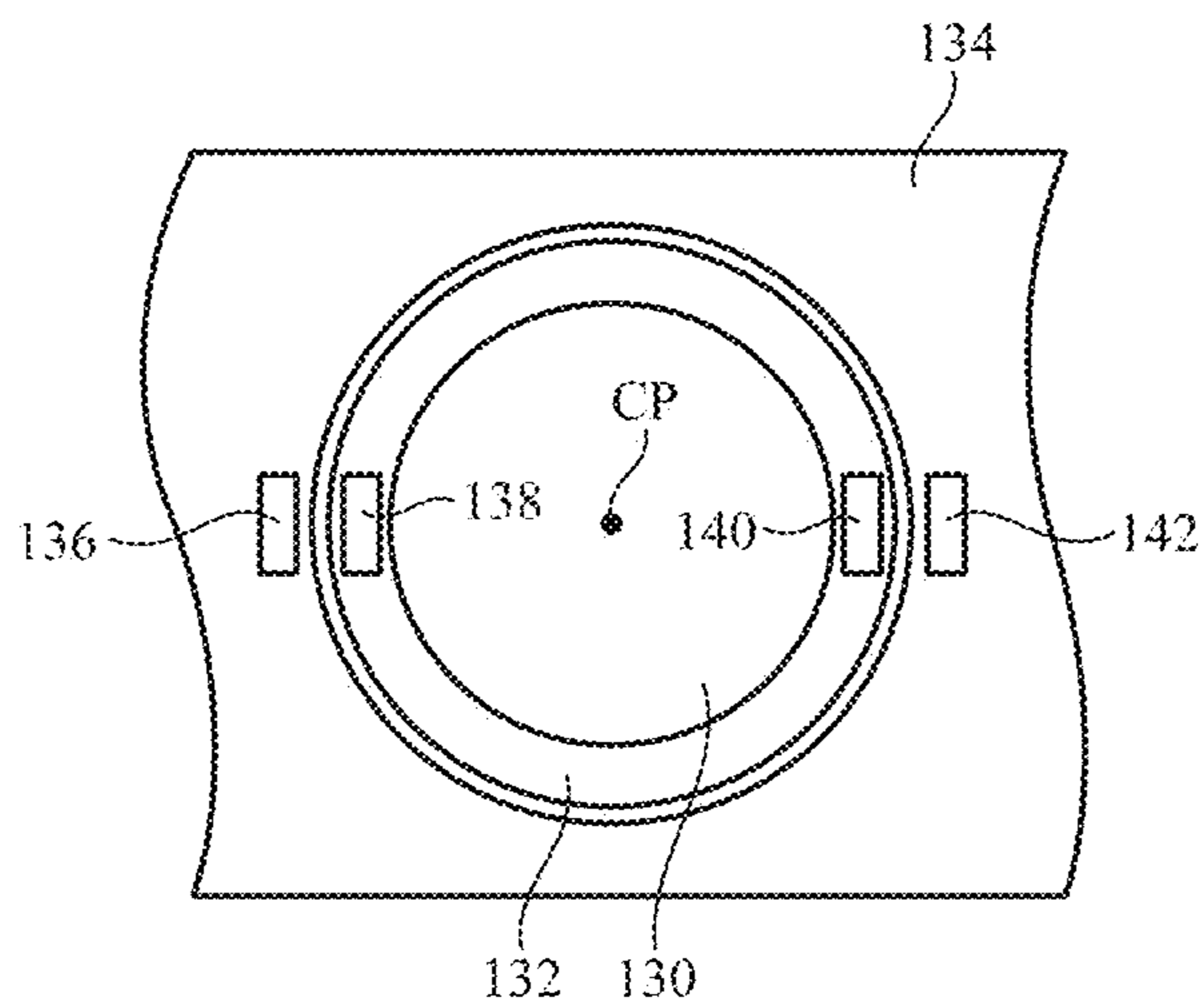

FIG. 11

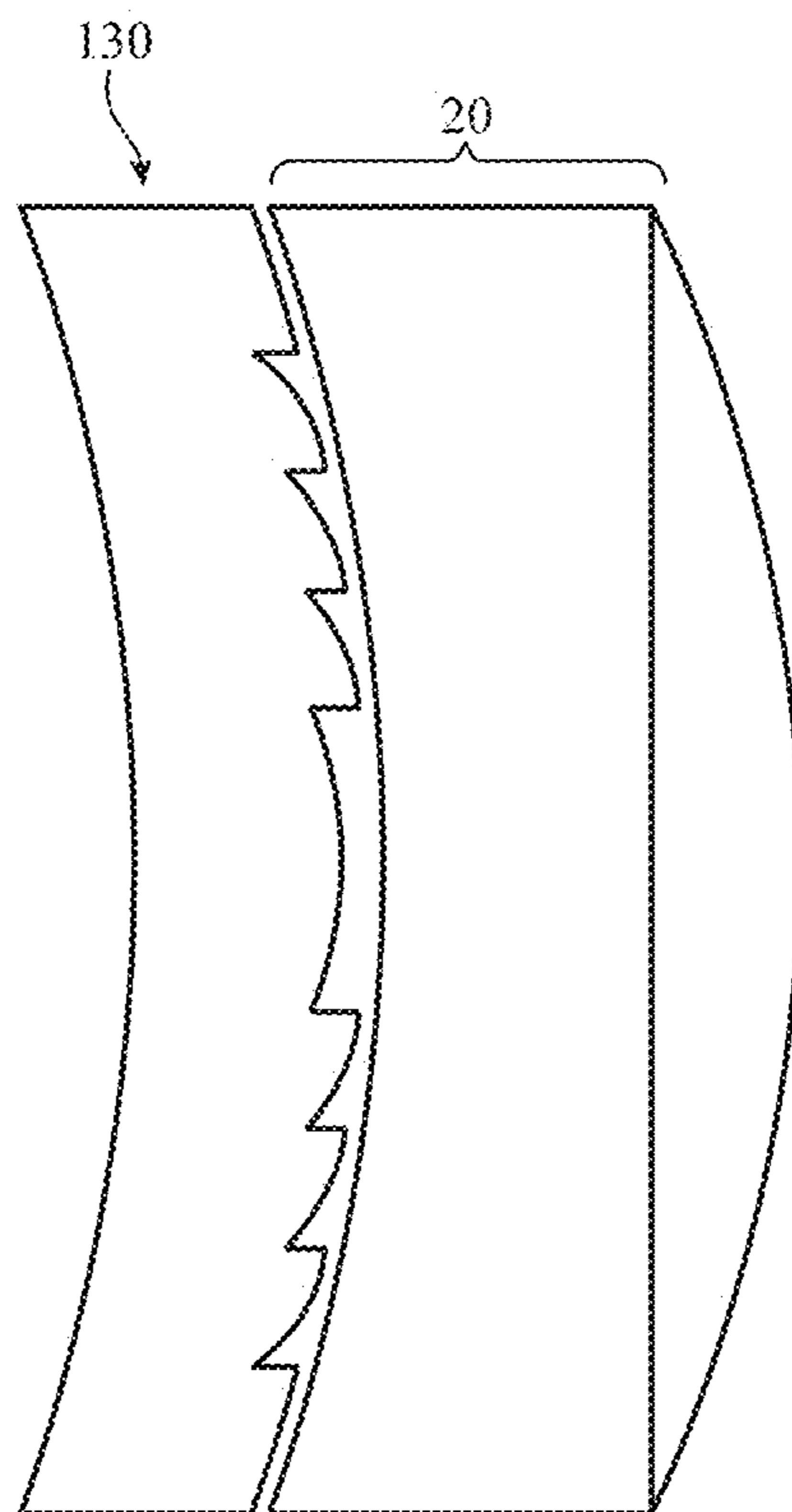

FIG. 12

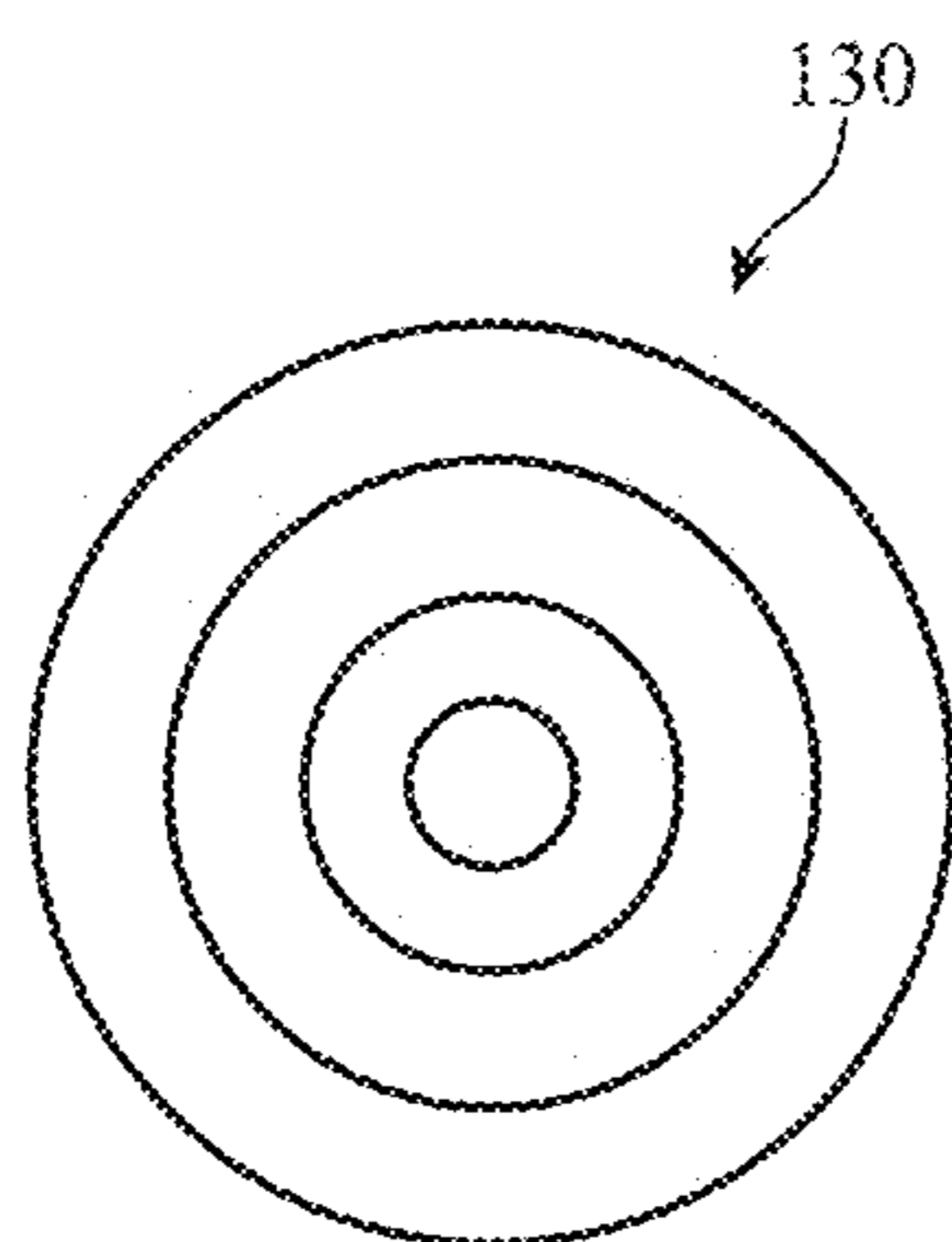

FIG. 13

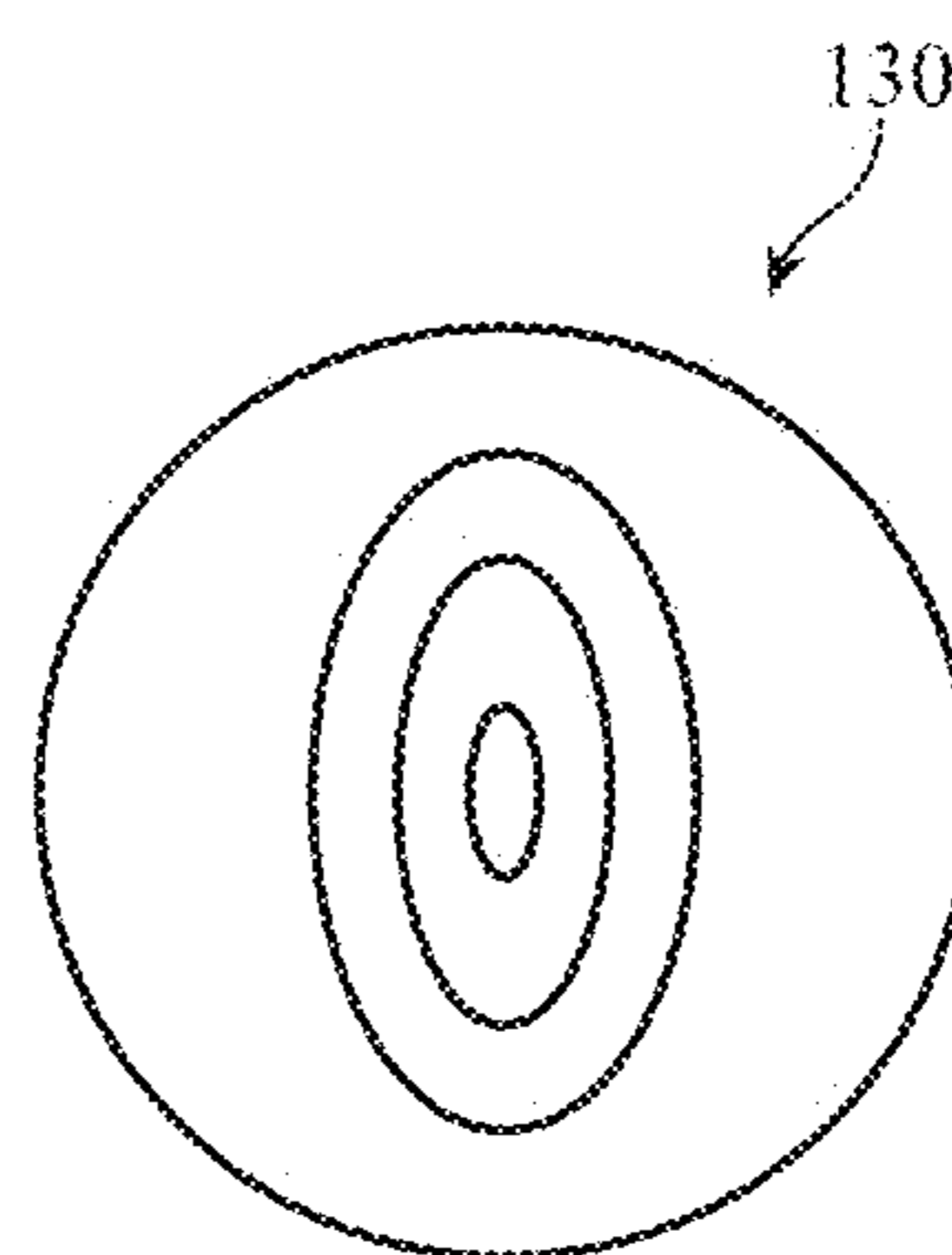

FIG. 14

HEAD-MOUNTED DISPLAY DEVICE WITH VISION CORRECTION

[0001] This application is a continuation of U.S. non-provisional patent application Ser. No. 16/612,336, filed Nov. 8, 2019, which is a national stage application of international application No. PCT/US2018/030832, filed May 3, 2018, which claims the benefit of U.S. provisional patent application No. 62/507,671, filed May 17, 2017. The disclosures of these applications are hereby incorporated by reference herein in their entireties.

BACKGROUND

[0002] This relates generally to optical systems and, more particularly, to optical systems for head-mounted devices.

[0003] Head-mounted devices such as virtual reality glasses and augmented reality glasses use displays to generate images and use lenses to present the images to the eyes of a user.

[0004] If care is not taken, a head-mounted device may be cumbersome and tiring to wear. Optical systems for head-mounted devices may be bulky and heavy and may not be sufficiently adjustable. Extended use of a head-mounted device with this type of optical system may be uncomfortable.

SUMMARY

[0005] A head-mounted display device may include a display system and an optical system in a housing. The display system may have displays that produce images. Positioners may be used to move the displays relative to a user's eyes. The positioners may be used to adjust the horizontal separation of the displays from each other to accommodate differences in interpupillary distance between users, may be used to make vertical display location adjustments to accommodate differences in facial anatomy between users, and may be used in adjusting eye-to-display spacing to alter focus.

[0006] The optical system may include tunable lenses such as tunable cylindrical liquid crystal lenses. The displays may be viewed through the lenses. The optical system may include fixed spherical lenses that are used in conjunction with the tunable cylindrical lenses.

[0007] A sensor may be incorporated into the head-mounted device to measure refractive errors in the user's eyes. Viewing comfort may be enhanced by adjusting display position relative to the eye positions of the user's eyes and/or by adjusting lens settings based on the content being presented on the display and/or based on measured eye refractive errors. The sensor may include waveguides and volume holograms and a camera for gathering light that has reflected from the retinas of the user's eyes. Refractive errors such as farsightedness, nearsightedness, and astigmatism may be corrected by tuning the lenses and/or adjusting display positions.

BRIEF DESCRIPTION OF THE DRAWINGS

[0008] FIG. 1 is a diagram of an illustrative head-mounted device in accordance with an embodiment.

[0009] FIG. 2 is a diagram of an illustrative head mounted device with adjustable displays and lenses in accordance with an embodiment.

[0010] FIG. 3 is a cross-sectional side view of an illustrative adjustable lens in accordance with an embodiment.

[0011] FIG. 4 is a graph showing how the index of refraction of the lens of FIG. 3 may be adjusted in accordance with an embodiment.

[0012] FIG. 5 is a diagram showing how the index of refraction of the lens of FIG. 3 may be adjusted when forming a Fresnel lens in accordance with an embodiment.

[0013] FIG. 6A is a diagram of an illustrative Shack-Hartmann sensor for a head-mounted device in accordance with an embodiment.

[0014] FIGS. 6B, 6C, and 6D are diagrams of alternative light sources for the Shack-Hartmann sensor in accordance with embodiments.

[0015] FIGS. 7A and 7B are diagrams of source and detector portions of a Tscherning sensor in accordance with an embodiment.

[0016] FIGS. 8A and 8B are diagrams of source and detector portions of a ray tracing sensor in accordance with an embodiment.

[0017] FIG. 9 is a flow chart of illustrative operations involved in operating a head-mounted device in accordance with an embodiment.

[0018] FIG. 10 is a side view of illustrative lens and an associated vision correction lens in accordance with an embodiment.

[0019] FIG. 11 is a front view of an illustrative vision correction lens coupled to a lens mount in accordance with an embodiment.

[0020] FIG. 12 is a side view of an illustrative lens and associated Fresnel vision correction lens in accordance with an embodiment.

[0021] FIG. 13 is a front view of an illustrative spherical Fresnel lens in accordance with an embodiment.

[0022] FIG. 14 is a front view of an illustrative cylindrical Fresnel lens in accordance with an embodiment.

DETAILED DESCRIPTION

[0023] Head-mounted devices such as head-mounted displays may be used for virtual reality and augmented reality systems. For example, a pair of virtual reality glasses that is worn on the head of a user may be used to provide a user with virtual reality content.

[0024] An illustrative system in which a head-mounted device such as a pair of virtual reality glasses is used in providing a user with virtual reality content is shown in FIG. 1. As shown in FIG. 1, head-mounted display 10 may include a display system such as display system 40 that creates images and may have an optical system such as optical system 20 through which a user (see, e.g., user's eyes 46) may view the images produced by display system 40 in direction 48.

[0025] Display system 40 may be based on a liquid crystal display, an organic light-emitting diode display, a display having an array of crystalline semiconductor light-emitting diode dies, a liquid-crystal-on-silicon display, a microelectromechanical systems (MEMs) display, and/or displays based on other display technologies. Separate left and right displays may be included in system 40 for the user's left and right eyes or a single display may span both eyes.

[0026] Visual content (e.g., image data for still and/or moving images) may be provided to display system 40 using control circuitry 42 that is mounted in head-mounted device 10 and/or control circuitry that is mounted outside of head-

mounted device **10** (e.g., in an associated portable electronic device, laptop computer, or other computing equipment). Control circuitry **42** may include storage such as hard-disk storage, volatile and non-volatile memory, electrically programmable storage for forming a solid-state drive, and other memory. Control circuitry **42** may also include one or more microprocessors, microcontrollers, digital signal processors, graphics processors, baseband processors, application-specific integrated circuits, and other processing circuitry. Communications circuits in circuitry **42** may be used to transmit and receive data (e.g., wirelessly and/or over wired paths). Control circuitry **42** may use display system **40** to display visual content such as virtual reality content (e.g., computer-generated content associated with a virtual world), pre-recorded video for a movie or other media, or other images.

[0027] System **40** may include electrically controlled positioners that can be used to adjust the positions of the displays in system **40**. Lens system **20** may include tunable lenses. During operation, control circuitry **42** may make position adjustments to the displays in system **40**, may adjust the tunable lenses in lens system **20**, and/or may make other adjustments to the components of device **10** while using system **40** to present the user with image content.

[0028] Input-output devices **44** may be coupled to control circuitry **42**. Input-output devices **44** may be used to gather user input from a user, may be used to make measurements on the environment surrounding device **10**, may be used to provide output to a user, and/or may be used to supply output to external electronic equipment. Input-output devices **44** may include buttons, joysticks, keypads, keyboard keys, touch sensors, track pads, displays, touch screen displays, microphones, speakers, light-emitting diodes for providing a user with visual output, and sensors (e.g., force sensors, temperature sensors, magnetic sensor, accelerometers, gyroscopes, and/or other sensors for measuring orientation, position, and/or movement of glasses **10**, proximity sensors, capacitive touch sensors, strain gauges, gas sensors, pressure sensors, ambient light sensors, and/or other sensors). If desired, input-output devices **44** may include a sensing system that measures the eye characteristics of the user's eyes **46**. For example, a wavefront sensor such as a Shack-Hartmann wavefront sensor, Tscherning sensor, or a ray tracing sensor may be used to measure refractive errors in a user's eyes such as astigmatism, farsightedness, and nearsightedness. Devices **44** can also include cameras (digital image sensors) for capturing images of the user's surroundings, cameras for performing gaze detection operations by viewing eyes **46**, and/or other cameras.

[0029] FIG. 2 is a diagram of portions of head-mounted device **10** viewed in direction **48** of FIG. 1 (along the Z axis in FIG. 2). As shown in FIG. 2, optical system components such as left lens **20L** and right lens **20R** and display system components such as left display **40L** and right display **40R** for device **10** may be mounted in a housing such as housing **12**. Housing **12** may have the shape of a frame for a pair of glasses (e.g., head-mounted device **10** may resemble eyeglasses), may have the shape of a helmet (e.g., head-mounted device **10** may form a helmet-mounted display), may have the shape of a pair of goggles, or may have any other suitable housing shape that allows housing **12** to be worn on the head of a user. Configurations in which housing **12** supports optical system **20** and display system **40** in front of a user's eyes (e.g., eyes **46**) as the user is viewing optical system **20** and display system **40** in direction **48** may

sometimes be described herein as an example. If desired, housing **12** may have other suitable configuration.

[0030] Housing **12** may be formed from plastic, metal, fiber-composite materials such as carbon-fiber materials, wood and other natural materials, glass, other materials, and/or combinations of two or more of these materials. Electrically controlled positioners (e.g., computer-controlled stepper motors, piezoelectric actuators, or other computer-controlled positioning devices that are controlled by control signals from control circuitry **42**) can be coupled to components of device **10** and used in positioning these components in desired positions relative to housing **12** and relative to the user wearing device **10**. For example, positioners **50X** may be used to adjust the respective X-axis positions of displays **40L** and **40R**. Positioners **50Y** may be used to adjust the respective positions of displays **40L** and **40R** along the Y-axis of FIG. 2. The Z-axis positions of displays **40L** and **40R** (respectively, the distances of displays **40L** and **40R** to the user's left and right eyes **46**) may be adjusted using positioners **50Z**. Positioners **50L** (e.g., X-axis, Y-axis, Z-axis, and/or rotational positioners) may be used in adjusting the positions of lenses **20L** and **20R**. Lens properties can also be electrically tuned in response to control signals from control circuitry **42**. The positioners in device **10** may be coupled to housing **12** (e.g., to move the position of a component relative to housing **12**) and/or may be coupled to movable structures in device **10** (e.g., to adjust the position of one component relative to another component or relative to a movable support structure). If desired, lens **20L** may be coupled to display **40L** using fixed support structures and lens **20R** may be coupled to display **40R** using fixed support structures so that the displays and corresponding lenses move together. In other configurations, the positions of lenses **20L** and **20R** can be fixed (or adjustable) with respect to the user's eyes while the positions of displays **40L** and **40R** relative to the user's eyes can be independently adjusted using the positioners for displays **40L** and **40R**. In some arrangements, lens positioners **50L** may be omitted. Arrangements in which lens positioners only provide rotational positioning for lenses **20L** and **20R** may also be used.

[0031] The adjustability of the positions of displays **40L** and **40R** and/or of lenses **20L** and **20R** along the Z-axis allows images on displays **40L** and **40R** to be brought into focus for the user. Inward and outward position adjustments parallel to the X-axis allow device **10** to accommodate users with different interpupillary distances; each lens and panel pair (corresponding to one eye) must be adjusted together. Adjustments along the Y dimension may allow device **10** to accommodate differences in user head and face anatomy (e.g., to place the displays and lenses at different heights along axis Y relative to the user's eyes). Positioner operations may be controlled in response to user input. For example, control circuitry **42** can use the positioners of FIG. 2 to make position adjustments based on button press input, touch sensor input, voice input, on-screen menu selections, and/or other user input to devices **44** of FIG. 1. Position adjustments (e.g., for focus tuning) can also be made by control circuitry **42** automatically based on measured refractive characteristics of the eyes of a user.

[0032] In addition to using lens movement and/or display movement to perform focusing operations, lenses **20L** and **20R** may be electrically tuned based on control signals from control circuitry **42**. Lenses **20L** and **20R** may be, for example, tunable lenses such as tunable liquid crystal lenses

or other lenses that can be dynamically tuned to exhibit different focal lengths. In the example of FIG. 3, tunable lens 20T (e.g., lens 20L and/or lens 20R) has been formed from a pair of orthogonally oriented stacked tunable cylindrical lenses. In particular, tunable lens 20T has a first tunable cylindrical lens CL1 and a second tunable lens CL2 formed from liquid crystal lens structures. Polarizers (e.g., linear polarizers with aligned pass axes) may be placed above CL2 and below CL1.

[0033] Lens 20T may include substrates such as substrates 52. Substrates 52 may be formed from clear plastic, transparent glass, or other suitable transparent material. Transparent conductive electrodes such as electrodes 54, 56, 58, and 60 may be formed on substrates 52. The transparent conductive electrodes may be formed from indium tin oxide or other transparent conductive material. Photolithography and etching, shadow mask patterning, or other patterning techniques may be used in patterning the electrodes into desired shapes (e.g., rings, strips, pads in an array, etc.).

[0034] With one illustrative configuration, which is shown in FIG. 3, lower electrode 54 of tunable cylindrical lens CL1 is formed from a blanket layer of transparent conductive material and upper electrode 56 of tunable cylindrical lens CL1 is formed from patterned strips of transparent conductive material running parallel to the Y axis. Liquid crystal material 62 is interposed between electrode 54 and electrode 56. The index of refraction of liquid crystal material varies as a function of applied voltage (electric field through the liquid crystal). By independently adjusting the voltages on each of electrodes 56 across dimension X, the index of refraction of liquid crystal material 62 can be adjusted under each electrode 56 and the focal length of cylindrical lens CL1 can therefore be adjusted.

[0035] Because electrodes 56 run along the Y axis of FIG. 3, the elongated axis of cylindrical lens CL1 also runs parallel to the Y axis. In upper tunable cylindrical lens CL2, liquid crystal material 64 is interposed between electrode 60 and electrode 58. Electrode 58 may be a uniform layer of transparent conductive material and upper electrode 60 may be formed from patterned strips of transparent conductive material running parallel to the X-axis. By adjusting the voltages applied to the electrode strips of electrode 60, the focal length of tunable cylindrical lens CL2 may be adjusted. The electrode strips of electrode 60 extend along the X-axis, so the longitudinal axis of lens CL2 also extends along the X axis. Because lenses CL1 and CL2 are perpendicular to each other, selected cylindrical lens powers in orthogonal directions may be produced through tuning of lenses CL1 and CL2. Spherical lens powers may be produced by driving both CL1 and CL2 (electrodes in X and Y) parametrically.

[0036] FIG. 4 is a graph showing how the focal length of a tunable cylindrical lens (e.g., the focal length of CL1) can be adjusted. In a first configuration, a smoothly varying profile of voltages is applied to across the electrode strips of the tunable cylindrical lens, causing the index-of-refraction n for the lens to be characterized by refractive index profile 66 of FIG. 4. The value of refractive index n varies in a curved shape across dimension X, thereby creating a cylindrical lens from the liquid crystal material.

[0037] To tune the lens, another smoothly varying voltage profile (e.g., with a larger magnitude) may be applied to the liquid crystal material, thereby creating refractive index profile 68. As these examples demonstrate, the refractive index profile of a tunable cylindrical lens can be adjusted

dynamically to adjust the focal length of the lens (e.g., to have a longer focal length and weaker lens power as illustrated by profile 66 or to have a shorter focal length and stronger lens power as illustrated by profile 68). If desired, index-of-refraction profiles of the type shown by tunable cylindrical lens index profile 70 of FIG. 5 may be dynamically produced to implement a cylindrical lens of a desired power using a Fresnel lens configuration.

[0038] In a tunable lens configuration of the type shown by lens 20T, the longitudinal axes of lenses CL1 and CL2 are orthogonal, allowing a cylindrical lens to be dynamically produced along either the X or Y axis. To help correct the vision of a user with astigmatism, cylindrical lens power along the X and/or Y dimensions can be controlled using lenses CL1 and CL2 of tunable lens 20T. If desired, a tunable cylindrical lens may be rotated using a positioner. For example, lens system 20 may include a mechanically or electrically rotatable cylindrical tunable lens of varying power (e.g., to compensate for eye astigmatism that is not symmetrical about the X or Y axis). Configurations in which the angular orientation of lens 20T is fixed and electrical tuning is used to tune lens CL1 and/or lens CL2 are described herein as an example.

[0039] Lens system 20 may include a fixed (or tunable) spherical lens in alignment with lens 20L and a fixed (or tunable) spherical lens in alignment with lens 20R. When a spherical lens is combined with a tunable cylindrical lens, device 10 may adjust tunable lenses in system 20 to correct the vision of a user's eye using a spherical equivalent (e.g., a combination of a spherical lens and a cylindrical lens of appropriate powers to approximate a desired aspherical lens for correcting a user's astigmatism).

[0040] If desired, a sensor that is configured to operate as an aberrometer (e.g., a Shack-Hartmann, Tscherning, or ray tracing sensor or other suitable refractive error measurement equipment) may be used by control circuitry 42 to automatically measure refractive errors in the user's eyes. Holographic couplers, waveguides, and other structures of the type shown in FIG. 6A may be used in forming the wavefront sensor so that the wavefront sensor can be reduced in size sufficiently to be carried in head mounted device 10.

[0041] Device 10 may include displays such as illustrative display 40 of FIG. 6A. Each display 40 may have an array of pixels P for generating images. As described in connection with FIG. 2, device 10 may have two displays (e.g., displays 40L and 40R) for providing images for the user's left and right eyes 46, respectively. Only one eye 46 and one corresponding display 40 are shown in the example of FIG. 6A.

[0042] Position sensors of the type shown in FIG. 2 may be used in adjusting the position of display 40 relative to eye 46 so that the images are in focus and can be comfortably viewed by the user. For example, the separation between display 40 and eye 46 can be adjusted using a Z-axis positioner (as an example). Lens system 20 may include fixed and/or tunable lenses (e.g., a fixed and/or tunable spherical lens, tunable cylindrical lenses, etc.).

[0043] In a Shack-Hartmann sensor configuration of the type shown in FIG. 6A, light source 72 and camera 106 may be used in supplying light to eye 46 and measuring reflected light to measure the optical properties of eye 46. Light source 72 may produce light 74 at any suitable wavelength. For example, light source 72 may be an infrared light source such as a laser or light-emitting diode that produces near

infrared light (e.g., light at 750-1400 nm, light with a wavelength of at least 700 nm, light with a wavelength of at least 750 nm, light with a wavelength of at least 800 nm, light with a wavelength of less than 1500 nm, light with a wavelength of less than 1000 nm, light with a wavelength of less than 900 nm, or light with a wavelength of less than 850 nm, etc.). Other wavelengths of light (longer infrared wavelengths, visible wavelengths, etc.) can also be used if desired.

[0044] For a light source such as a laser, objective lens 75, pinhole aperture 76, collimating lens 80, and iris 81 may be used to collimate and control the beam size of light 74. These optical elements make up collimation optics assembly 71. Objective lens 75 focuses light 74 onto pinhole aperture 76, which acts as a spatial filter that removes uneven intensity distributions in the beam. A beam with a smooth Gaussian profile emerges from pinhole aperture 76. Lens 80 may be used to collect and collimate the spatially filtered light. Iris 81 may be used to control the collimated beam size. The lenses and apertures in assembly 71 may be fixed components, or may be adjusted either manually or electronically in response to control signals from control circuitry 42.

[0045] Light source 72 may be a light-emitting diode (LED) 73 that emits at any suitable wavelength. Because of the finite size of the LED, the beam will diverge slightly after collimation. For an LED source, collimation optics assembly 71 may contain different components to mitigate beam divergence after collimation. FIG. 6B shows a configuration an aspheric lens pair 77A collimates the light 74 from LED source 73. If desired, a single aspheric lens can be used for collimation instead. In FIG. 6C, collimation optics assembly 71 may contain just an LED 73 and compound parabolic concentrator 77B. By sitting at the focus of the hollow parabolic minor 77C, light 74 can be collected and collimated. Parabolic concentrator 77B is advantageous in cases where the LED source 73 carries a large emission profile that cannot fully be captured by a simple lens. In FIG. 6D, assembly 71 may contain a lens array pair 77C and condenser lens 79. The combination of two lens arrays produces uniform illumination whose beam size can be controlled by condenser lens 79. If desired, a single lens array may be used instead.

[0046] Input and output couplers such as volume holograms or other holographic couplers may be used in coupling light into and out of the ends of waveguides 84 and 94. The couplers are directional, meaning that light can enter the volume hologram in one direction. For example, input coupler 82 may be used to couple light 74 into waveguide 84. Once coupled into waveguide 84, this light may travel to output coupler 86 in direction 93 within waveguide 94. Output coupler 86 may be aligned with user's eye 46 (e.g. output coupler 86 may be interposed between display 40 (and lens 20) and the user's eye 46. With this configuration, output coupler 86 couples light that is traveling in direction 93 in waveguide 94 out of waveguide 94 and towards eye 46 as indicated by output light 88. This illuminates the user's eye with light 74. After passing through the lens of eye 46, light 88 is reflected in direction 48, as indicated by reflected light 90. Input coupler 92 couples light 90 into waveguide 94. Couplers 86 and 92 may be tuned to the wavelength of light 74 and may therefore be transparent to the user as the user is viewing images on display 40 in direction 48.

[0047] In waveguide 94, light collected from input coupler 92 travels to output coupler 83 in direction 96. Output coupler 83 couples the light exiting waveguide 94 that is traveling in direction 96 towards camera 106 as output light 91. Output light 91 passes through lens 98, low pass filter 100 (which is located at the focus of lens 98 and is used to filter out noise from the light), and lenslet array 102. Lenslet array 102 may include a two-dimensional array of lenses. These lenses focus light 91 onto camera 106 (e.g., a digital image sensor) in a two-dimensional array of spots 104.

[0048] The individual intensities of the spots in the two-dimensional pattern of spots 104 at camera 106 can be analyzed by control circuitry 42 to characterize any refractive errors present in user's eye 46 (e.g., astigmatism, nearsightedness, or farsightedness). With one illustrative arrangement, control circuitry 42 fits Zernike polynomials to the measured intensities of spots 104 and processes the Zernike polynomials to determine the user's eye refractive errors (e.g. a diopter value or other eyeglasses prescription information specifying optical system settings to correct the user's vision by correcting refractive errors associated with eye 46). The information on the measured refractive errors can then be used by control circuitry 42 to adjust the position of display 40 relative to eye 46 and/or to adjust one or more tunable lenses in optical system 20.

[0049] Consider, as an example, a nearsighted user with astigmatism having a right eye (OD) prescription of sphere: -3.00 diopters, cylinder: -1.50 diopters, axis: 180°. This prescription indicates that the user needs spherical and cylindrical corrections of -3.00 and -1.5 diopters, respectively. The axis value of 180° indicates the user's astigmatism correction is horizontal. In this scenario, the spherical correction can be obtained by adjusting the separation between display 40 and eye 46 with the Z-axis positioner and the cylindrical correction can be obtained by tuning the horizontally oriented tunable cylindrical lens to produce -1.5 diopters of cylindrical lens power. The user's right eye refractive errors can be independently corrected by control circuitry 42 based on the measured characteristics of the user's right eye.

[0050] The content that is provided to the user may contain distant images (e.g., images of mountains) and may contain foreground content (e.g., an image of a person standing 50 cm from the user). Three-dimensional content can be provided by presenting slightly different images to the user's left and right eyes with respective displays 40L and 40R.

[0051] Accommodation-vergence mismatch has the potential to lead to eyestrain. To minimize eyestrain, device 10 may perform operations that help allow the user's ciliary muscles to relax. For example, control circuitry 42 may periodically (e.g., every 20 minutes) present distant content (e.g., content at an apparent distance of at least 20 feet away) to the user and may direct the user to look at this distant content for a predetermined amount of time (e.g., 20 seconds). Adjustments can also be made to the diopter correction or other optical system settings associated with device 10 to help enhance user eye comfort. For example, device 10 can be calibrated during manufacturing so that control circuitry 42 is able to place display 14 and optical system 20 in a low-eye-strain configuration during normal operation. When calibrating device 10, device 10 can be tested to determine the position of display 40 that corresponds to a

virtual image at infinity focus. This calibration information may then be stored in control circuitry 42.

[0052] If a user has perfect vision (no eye correction needed) and if device 10 is displaying distant content (e.g., content for which the user's vergence is associated with an object located at an infinite distance from the user), device 10 can adjust optical system 20 so that the extra diopter power of device 10 is zero. In this arrangement, the user will be able to comfortably view the distant content without eyestrain.

[0053] If, as another example, the user is nearsighted and typically needs a -1.00 diopter lens for comfortable viewing of distant images, control circuitry 42 can make a -1.00 diopter adjustment when distant images are presented and corresponding increased diopter changes as closer content is being presented.

[0054] If desired, eye characteristics can be sensed using a Tscherning sensor system or a ray tracing sensor system in addition to or instead of using a Shack-Hartmann sensor to measure refractive errors.

[0055] Portions of an illustrative Tscherning sensor system (Tscherning aberrometer) are shown in FIGS. 7A and 7B. In a Tscherning sensor system, collimated light 74 from a light source such as laser 72 or LED 73 is passed through a mask such as mask 120. Mask 120 has an array of openings such as an array of circular openings in a grid pattern having rows and columns. The presence of mask 120 converts light 74 into a series of parallel beams aligned with the array of openings in mask 120. These parallel beams are coupled into waveguide 84 and directed to eye 46 as light 88 as described in connection with FIG. 6A. After passing through eye 46 and forming images on the user's retina, these light beams return to waveguide 94 as light 90 (FIG. 6A). Waveguide 94 supplies light 90 to lens 122 as light 91, as shown in FIG. 7B. Camera 106 can measure the resulting array of spots of light associated with the reflected beams of light after light 91 passes through lens 122. Control circuitry 42 can analyze the measurements made by camera 106 to characterize refractive errors for the user's eye (e.g., using Zernike polynomials).

[0056] If desired, light source 72, mask 120, and waveguide 84 may be omitted and the array of light beams that would otherwise be passing through mask 120 may be generated instead by presenting an array of spots on display 40. Just prior to sensing the user's eyes, the user's eyes may be placed in a relaxed condition by forming an image on display 40 and moving this virtual target to infinity (e.g., by slowly increasing the separation between display 40 and eyes 46 until the infinity focus position has been reached and/or by tuning lenses in system 20). In this type of scenario, the light spots in the array may pass from display 40 to eye 46 without being routed to eye 46 using waveguide 84. Reflected light 90 may be supplied (as light 91) to camera 106 for analysis by control circuitry 42 (e.g., Zernike polynomial fitting, etc.).

[0057] Portions of a ray tracing aberrometer are shown in FIGS. 8A and 8B. In a ray tracing system, a beam of light 74 from a light source such as laser 72 or LED 73 is scanned by an electrically controlled beam scanning device such as scanning mirror 124 (e.g., a mirror or other device controlled by control circuitry 42). The scanned beam is projected on the retina of eye 46 by waveguide 84 while the intensity of light 74 is pulsed by laser 72 or LED 73. This assembly forms an array of spots on the retina of eye 46. As each spot

is projected onto eye 46 in sequence, reflected light for that spot (see, e.g., light 90 of FIG. 6A) is directed through waveguide 94 to lens 122 as light 91 of FIG. 8B. After passing through lens 122, camera 106 can capture an image of each of the spots and control circuitry 42 can analyze the captured image data (e.g., using Zernike polynomial fitting).

[0058] If desired, light for a ray-tracing sensing system (ray-tracing aberrometer) may be produced by forming patterns on display 40 after relaxing the user's eye 46. For example, a circle (ring of light) or other pattern may be formed on display 40. The user's eye 46 may be relaxed by moving the virtual target formed by the circle or other pattern to an infinity focus position before eye measurements are made. In this type of configuration, light source 72, mask 120, and waveguide 84 may be omitted. During measurements, the circular pattern of light on display 40 is directed onto the user's retina and reflected as reflected light 90. After passing through waveguide 94 in direction 96 and exiting as light 91, camera 106 can capture images of the circle (which may have the shape of an ellipse) for analysis by control circuitry 42. The magnification of the ellipse can be used in determining the spherical portion of the user's prescription, the major and minor axis of the ellipse can be used in determining the cylindrical portion of the user's prescription, and the axis of the user's prescription can be determined from the angle of the major axis of the ellipse measured with camera 106.

[0059] Illustrative operations involved in using device 10 are shown in FIG. 9.

[0060] During the operations of block 108, device 10 may be calibrated. For example, device 10 (or a representative device in a batch of devices being calibrated) can be characterized using test equipment. During testing, display 40 may create a test image while control circuitry 42 directs positioners in device 10 to position display 40 at its infinity focus location and directs lenses in lens system 20 to tune to their infinity focus location. An image sensor (e.g., a dummy eye) or other test sensor may be placed in the position of the user's eye while the image is displayed. Display position offsets and/or lens tuning offsets that might be needed to bring the virtual image at infinity into focus on the test sensor may then be determined and stored in device 10 to calibrated device 10 for future use by a user.

[0061] During user operations at block 110, device 10 may be adjusted (automatically and/or manually) so that lenses 20 and displays 40 are at appropriate locations relative to the user's eyes and face (e.g., so that lenses 20 and displays 40 are separated by an appropriate distance that matches the user's interpupillary distance, so that lenses 20 and displays 40 have appropriate Y locations, etc.). After these initial adjustments have been performed, device 10 may use an eye sensing system (e.g., an aberrometer such as a Hartmann-Shack, Tscherning, or ray tracing sensor or other suitable refractive error measurement equipment) to measure the characteristics of a user's eye (e.g., to automatically measure refractive errors for the user's eyes and therefore determine a user's eye prescription for both the user's left and right eyes). If desired, a user may manually supply information on the user's prescription to control circuitry 42 using input-output devices. A user may, for example, be prompted to supply prescription values (sphere, cylinder, axis) using a touch screen, keys, voice input, etc.

[0062] During the operations of block 112, control circuitry may adjust the position of display 40 (e.g., the

separation in dimension *Z* of the left display from the user's left eye and the separation in dimension *Z* of the right display from the user's right eye) and/or may adjust tunable lenses in optical system 10 to bring content on display 40 into focus for the user while correcting for astigmatism, farsightedness, nearsightedness, and other refractive errors in the user's vision. The focus may be adjusted based on the nature of the content being displayed (e.g., based on the whether the content is distant content such as mountains in a landscape or is close-up content such as a nearby person) to minimize accommodation-vergence mismatch while taking into account user preferences and user refractive errors.

[0063] After the focus is adjusted at block 112, control circuitry 42 may use display system 40 to display images for the user. While displaying the images, control circuitry 42 can determine whether any of the content is associated with distant objects (distant virtual objects such as computer-generated distant mountains in a landscape) or is otherwise associated with the user's relaxed eye focus state (eyes focusing at infinity). A timer may be maintained to track the amount of time elapsed between periods in which long-distance (e.g., infinity focus) content is being displayed for more than a predetermined amount of time (e.g., at least 20 seconds, at least 10 seconds, a threshold amount of time less than 2 minutes, etc.).

[0064] When the timer expires (e.g., after at least 15 minutes, at least 20 minutes, 10-30 minutes, a time period of less than 40 minutes, or other suitable time limit beyond which the user is not allowed to continue without eye relaxation), control circuitry 42 can conclude that it is time for the user to relax their eyes. Accordingly, content at a large distance (e.g., at infinity or greater than 20 feet away) can be presented to the user (block 116). As the user views this distant content (and as control circuitry 42 adjust the position of display 40 and optical system 20 to their corresponding infinity focus states), the user's ciliary muscles in eyes 46 relax. After a suitable eye relaxation period has passed (e.g., after at least 10 s, at least 20 s, at least 30 s, at least 15-30 s, a time period less than 3 min, or other suitable relaxation time period), processing may return to block 112, as indicated by line 118. The eye relaxation content (long distance) content that is displayed during the operations of block 116 may include a message such as "relax eyes" that is presented at an infinity focus point or other suitably large distance or may include embedded content (e.g., mountains at an infinity focus or other suitable large distance) that is forced into the content that is otherwise being presented to the user. For example, a user playing a video game may be in a confined space and close to surrounding objects. To allow the user's eyes to relax during the operations of block 116, a distant mountain scene may be inserted into the video game, thereby avoiding the need to interrupt the user with a text message ("relax eyes") or other content that might disrupt the user's enjoyment of the video game.

[0065] A user of device 10 may not have perfect vision. For example, a user may be nearsighted, may be farsighted, and/or may have astigmatism. To correct for imperfect vision, vision correction lenses may be coupled to device 10. Lenses 20 may, for example, have a fixed portion and a removable vision correction portion.

[0066] Vision correction lenses may, for example, have a positive diopter (to correct for farsightedness or a negative diopter (to correct for nearsightedness). Astigmatism may also be corrected. Corrective lenses that correct for astig-

matism are not be rotationally symmetric. To ensure that vision correction lenses that are not rotationally symmetric are oriented properly, device 10 may be provided with vision correction lens orientation features (e.g., a magnetic coupling structure or mechanical coupling structure that accurately aligns the corrective lens while coupling the corrective lens to lens 20L or 20R in device 10 so that the corrective lens has a desired angular orientation with respect to device 10 and display 40 and therefore to the user's eyes when device 10 is being worn by the user).

[0067] An illustrative vision correction lens arrangement is shown in FIG. 10. In the example of FIG. 10, vision correction lens 130 has been mounted within device 10 overlapping lens 20. Lens 20 may be a catadioptric lens or other suitable lens. Lens 20 may be tunable or may be fixed. Lens 130 may be rotationally symmetric or may be rotationally asymmetric. As shown in FIG. 10, lens 130 may have a convex outer surface SF3 that faces lens 20 and may have a concave inner surface. In configurations in which lens 130 is rotationally asymmetric to compensate for astigmatism, the concave inner surface of lens 130 may be characterized by a first curvature (shown by cross-sectional profile SF1) along a first dimension (e.g., along the X axis) and may be characterized by a different second curvature (shown by cross-sectional profile SF2) along a second dimension (e.g., along the Y axis). When lens 130 overlaps lens 20, a two-part lens is formed that is corrected to compensate for the user's vision problems.

[0068] Vision correction lens 130 may have a support structure such as vision correction lens mounting ring 132. Lens 20 may be mounted in a support structure such as lens mounting structure 134 (e.g., a portion of a housing or other structural support in device 10). Structure 134 may have an opening (e.g., a circular opening or an opening of other suitable shape) that receives mounting ring 132. When ring 132 is received within structure 134, alignment features associated with ring 132 and structure 134 accurately align vision correction ring 130 with respect to structure 134 (e.g., the angular orientation of ring 132 and therefore vision correction lens 130 with respect to lens 20, display 40, and other portions of device 10 is established within less than 2°, within less than 4°, or other suitable amount).

[0069] With one illustrative configuration, magnetic alignment structures may be used on ring 132 and structure 134. As shown in FIG. 11, for example, lens 130 may be mounted within ring 132 and may potentially rotate with respect to center point CP as ring 132 rotates within a circular opening in support structure 134. To place vision correction lens 130 into a desired rotational alignment with respect to structure 134 and the rest of device 10, ring 132 may be provided with one or more magnets such as magnets 138 and 140 and structure 134 may be provided with one or more corresponding magnets 136 and 142. When vision correction lens 130 is mounted to device 10, magnetic attraction between magnet 138 and magnet 136 and magnetic attraction between magnet 140 and 142 will help align and hold lens 130 in a desired angular orientation within device 10, thereby ensuring that lens 130 satisfactorily corrects a user's astigmatism.

[0070] If desired, vision correction lens 130 may be a Fresnel lens, as shown in FIG. 12. Fresnel vision correction lens 130 (e.g., lens 130 of FIG. 12) may be a spherical lens (e.g., a rotationally symmetric lens) as shown in the front view of lens 130 of FIG. 13 or may be a cylindrical lens (e.g., a cylindrical lens with no spherical power or a hybrid

cylindrical-spherical lens) as shown in the front view of illustrative rotationally asymmetric lens **130** of FIG. **14**.

[0071] To ensure that a user's vision is corrected satisfactorily when using device **10**, vision correction lenses **130** may be coupled to device **10** in alignment with lenses **20** before use of device **10**. For example, a left vision correction lens may be coupled to device **10** in alignment with (overlapping) left lens **20L** and a right vision correction lens may be coupled to device **10** in alignment with right lens **20R**. Vision correction lenses **130** may be coupled to device **10** magnetically (e.g., using magnets and/or magnetic material), using threaded retention rings, using clips, using adhesive, and/or using other suitable mounting structures. In some configurations, vision correction lenses **130** are removably coupled to device **10** (e.g., so that a different user may replace the vision correction lenses **130** with a different set of vision correction lenses if desired).

[0072] When vision correction lenses **130** are incorporated into device **10**, lenses **130** and **20** operate together. For example, lenses **20** may serve to provide most of the optical power used in bringing display **40** into focus, while lenses **130** may correct for user-specific vision problems such as astigmatism, etc. If desired, tunable lens structures may be used in combination with vision correction lenses **130** and/or other fixed lenses (e.g., catadioptric lenses, Fresnel lenses, etc.).

[0073] In accordance with an embodiment, a head-mounted device configured to generate images viewable by a user having an eye with refractive errors that is located at an eye position is provided that includes a display configured to display the images, a lens through which the images are viewable, a sensor, a positioner coupled to the display, and control circuitry configured to measure the refractive errors with the sensor and configured to adjust the positioner based on the measured refractive errors.

[0074] In accordance with another embodiment, the sensor includes at least one waveguide.

[0075] In accordance with another embodiment, the sensor includes an input coupler that couples light into the waveguide and includes an output coupler that couples light out of the waveguide.

[0076] In accordance with another embodiment, the output coupler is configured to allow images to pass from the display to the eye position.

[0077] In accordance with another embodiment, the input coupler and output coupler are volume holograms.

[0078] In accordance with another embodiment, the sensor further includes a camera that measures light from the output coupler.

[0079] In accordance with another embodiment, the head-mounted device includes a light source selected from the group consisting of a laser and a light emitting diode that supplies light, an additional waveguide having an additional input coupler that couples the light into the additional waveguide and that has an additional output coupler that directs the light out of the additional waveguide towards the eye position.

[0080] In accordance with another embodiment, the head-mounted device includes a lens array interposed between the output coupler and the camera, the control circuitry is configured to measure the refractive errors by analyzing light spots produced by the lens array at the camera.

[0081] In accordance with another embodiment, the sensor is configured to form a Shack-Hartmann aberrometer.

[0082] In accordance with another embodiment, the sensor is configured to form a Tscherning aberrometer and the control circuitry is configured to measure the refractive errors by analyzing light spots at the camera that are produced while an array of dots are displayed on the display.

[0083] In accordance with another embodiment, the sensor is configured to form a ray tracing aberrometer and the control circuitry is configured to measure the refractive errors by analyzing a light pattern at the camera that is produced while a shape is displayed on the display.

[0084] In accordance with another embodiment, the shape includes a circle.

[0085] In accordance with another embodiment, the control circuitry is configured to allow the eye to relax by periodically presenting content on the display while adjusting at least a selected one of: the display and the lens to an infinity focus setting.

[0086] In accordance with another embodiment, the head-mounted device includes an input-output device, the control circuitry is configured to receive user input on the refractive errors with the input-output device.

[0087] In accordance with another embodiment, the user input includes an eyeglasses prescription and the control circuitry is configured to adjust a position of the display with the positioner based on the eyeglasses prescription.

[0088] In accordance with another embodiment, the lens includes a tunable lens and the control circuitry is configured to adjust the tunable lens based at least partly on the measured refractive errors.

[0089] In accordance with another embodiment, the tunable lens includes at least one tunable liquid crystal cylindrical lens, the measured refractive errors are associated with astigmatism in the eye, and the control circuitry is configured to adjust the tunable liquid crystal cylindrical lens based on the measured refractive errors to correct the astigmatism.

[0090] In accordance with another embodiment, the lens includes a vision correction lens.

[0091] In accordance with another embodiment, the vision correction lens is rotationally asymmetric and is configured to compensate for astigmatism.

[0092] In accordance with another embodiment, the vision correction lens is a Fresnel lens.

[0093] In accordance with another embodiment, the lens includes a fixed lens and a removable vision correction lens that is configured to overlap the fixed lens.

[0094] In accordance with another embodiment, the removable vision correction lens includes rotational alignment structures configured to rotationally align the removable vision correction lens relative to the fixed lens.

[0095] In accordance with another embodiment, the rotational alignment structures include a magnet.

[0096] In accordance with an embodiment, a head-mounted device is provided that includes a display configured to display images, a lens, a sensor that includes at least one hologram, and control circuitry configured to measure refractive errors in eyes with the sensor and configured to adjust at least one of: the lens and a position of the display based on the measured refractive errors.

[0097] In accordance with another embodiment, the sensor includes a camera, the refractive errors includes astigmatism, the lens includes an adjustable liquid crystal cylindrical lens, and the control circuitry is configured to adjust the

adjustable liquid crystal cylindrical lens to correct the astigmatism as the display is viewed.

[0098] In accordance with an embodiment, a head-mounted device is provided that includes a display, a lens through which the display is viewable from an eye position, a waveguide, a hologram on the waveguide through which the display is viewable from the eye position, a camera, and control circuitry configured to measure eye refractive errors based on measurements with the camera on light exiting the waveguide.

[0099] The foregoing is merely illustrative and various modifications can be made to the described embodiments. The foregoing embodiments may be implemented individually or in any combination.

What is claimed is:

1. A head-mounted device comprising:
 - a housing;
 - a display in the housing, wherein the display includes a pixel array configured to provide a display image; and
 - a fixed lens that is coupled to the housing and that overlaps the pixel array,
 wherein the housing is configured to receive a removable lens and wherein the display image is viewable through the fixed lens and the removable lens when received by the housing.
2. The head-mounted device defined in claim 1, wherein the removable lens is received at a location that overlaps the fixed lens and overlaps the pixel array.
3. The head-mounted device defined in claim 1, wherein the housing comprises a support structure configured to receive a corresponding mounting structure of the removable lens and wherein the mounting structure of the removable lens overlaps the support structure when received by the support structure.
4. The head-mounted device defined in claim 3, wherein the mounting structure of the removable lens comprises a mounting ring that surrounds a lens element of the removable lens.
5. The head-mounted device defined in claim 4, wherein the support structure of the housing has an opening in which the fixed lens is disposed.
6. The head-mounted device defined in claim 5, wherein the lens element overlaps the opening when the removable lens is received by the support structure.
7. The head-mounted device defined in claim 3 further comprising:
 - an alignment structure on the support structure configured to rotationally align the removable lens relative to the support structure.
8. The head-mounted device defined in claim 7, wherein the alignment structure on the support structure is configured to couple to a corresponding alignment structure on the removable lens to hold the removable lens in a particular rotational alignment with respect to the support structure.
9. The head-mounted device defined in claim 1, wherein the removable lens comprises a removable vision correction lens.
10. The head-mounted device defined in claim 1, wherein the removable lens comprises a spherical lens.
11. The head-mounted device defined in claim 1, wherein the removable lens comprises a cylindrical lens.

12. The head-mounted device defined in claim 1, wherein the display is a left display, wherein the fixed lens is a left fixed lens, wherein the removable lens is a left removable lens, the head-mounted device further comprising:

- a right display; and
- a right fixed lens, wherein the housing is configured to receive a right removable lens and wherein the right display is viewable through the right fixed lens and the right removable lens when received by the housing.

13. A head-mounted device comprising:

- a housing;
- a first display coupled to the housing and having a first pixel array;
- a first lens that is coupled to the housing and that overlaps the first pixel array;
- a second display coupled to the housing and having a second pixel array; and
- a second lens that is coupled to the housing and that overlaps the second pixel array, wherein the housing comprises support structures that are configured to receive a third lens at a location that overlaps the first lens and the first pixel array and receive a fourth lens at a location that overlaps the second lens and the second pixel array.

14. The head-mounted device defined in claim 13, wherein the first and second lenses are fixed within the housing and wherein the third and fourth lenses are detachable from the support structures of the housing.

15. The head-mounted device defined in claim 13, wherein the support structures provide first and second openings, wherein the location of the third lens overlaps the first opening, and wherein the location of the fourth lens overlaps the second opening.

16. The head-mounted device defined in claim 15, wherein the first lens is disposed within the first opening and wherein the second lens is disposed within the second opening.

17. A head-mounted device comprising:

- a housing;
- a display coupled to the housing, wherein the display includes a pixel array;
- a fixed lens that is coupled to the housing and that overlaps the pixel array; and
- an additional lens that is removably coupled housing and that overlaps the fixed lens and the pixel array.

18. The head-mounted device defined in claim 17, wherein the housing comprises a lens mounting structure to which a corresponding mounting structure of the additional lens is removably coupled.

19. The head-mounted device defined in claim 18, wherein the mounting structure of the additional lens comprises a mounting ring that surrounds a lens element of the removable lens.

20. The head-mounted device defined in claim 19, wherein the lens mounting structure of the housing has an opening in which the fixed lens is disposed and wherein the lens element overlaps the opening of the lens mounting structure.