



US009255393B2

(12) **United States Patent**
Trauth

(10) **Patent No.:** **US 9,255,393 B2**
(45) **Date of Patent:** **Feb. 9, 2016**

(54) **STORM WATER REDISTRIBUTION DEVICE**

(71) Applicant: **Kathleen M Trauth**, Columbia, MO
(US)

(72) Inventor: **Kathleen M Trauth**, Columbia, MO
(US)

(*) Notice: Subject to any disclaimer, the term of this patent is extended or adjusted under 35 U.S.C. 154(b) by 108 days.

(21) Appl. No.: **14/159,197**

(22) Filed: **Jan. 20, 2014**

(65) **Prior Publication Data**

US 2014/0202564 A1 Jul. 24, 2014

Related U.S. Application Data

(60) Provisional application No. 61/849,206, filed on Jan. 22, 2013.

(51) **Int. Cl.**
E03B 1/00 (2006.01)
E03F 1/00 (2006.01)

(52) **U.S. Cl.**
CPC . *E03F 1/002* (2013.01); *E03B 1/00* (2013.01);
Y10T 137/85938 (2015.04)

(58) **Field of Classification Search**
USPC 405/36; 137/561 A
See application file for complete search history.

(56) **References Cited**

U.S. PATENT DOCUMENTS

2,201,279	A *	5/1940	Willing	405/16
5,152,632	A *	10/1992	Hawkes	404/20
5,511,904	A *	4/1996	Van Egmond	405/52
5,595,458	A *	1/1997	Grabhorn	405/302.6

5,750,026	A *	5/1998	Gadkaree et al.	210/502.1
5,948,250	A *	9/1999	Middleton	C02F 1/40 210/232
5,951,202	A *	9/1999	Brown	405/19
6,368,017	B2 *	4/2002	Black	405/15
7,056,057	B2	6/2006	Marchant		
7,226,240	B2	6/2007	Tyler		
7,449,105	B2 *	11/2008	Hastings	E02D 29/0291 210/170.03
2001/0007309	A1 *	7/2001	Malone et al.	210/170
2002/0155237	A1 *	10/2002	Allard	428/36.1
2004/0005198	A1 *	1/2004	Spangler	E02B 3/04 405/302.6
2007/0253785	A1 *	11/2007	Tyler	405/302.6
2012/0230766	A1 *	9/2012	Schnaars, Sr.	E02D 29/0291 405/32

* cited by examiner

Primary Examiner — Benjamin Fiorello
Assistant Examiner — Kyle Armstrong
(74) *Attorney, Agent, or Firm* — Erickson Kernell
Derusseau & Kleypas, LLC

(57) **ABSTRACT**

A storm-water redistribution device and installation are described for providing headloss and redistribution of a flow of storm-water runoff. The device includes an elongate, tubular, geotextile enclosure having a plurality of transverse partitions therein that form a plurality of segments along the length of the device. Each segment is filled with a particulate material, such as gravel having a desired grade size or distribution thereof. Longitudinal partitions are provided to form one or more transversely positioned compartments. The device is installed perpendicular to a slope to intercept runoff flows. The flow infiltrates the device and is diverted into vertical infiltrating flow, longitudinal flow that distributes the flow along the device length, and transverse flow that exits the opposite side of the device as overland or subsurface flow of reduced velocity. The partitions enable retention of the particulate materials in desired positions within the device during manipulation and use.

20 Claims, 6 Drawing Sheets

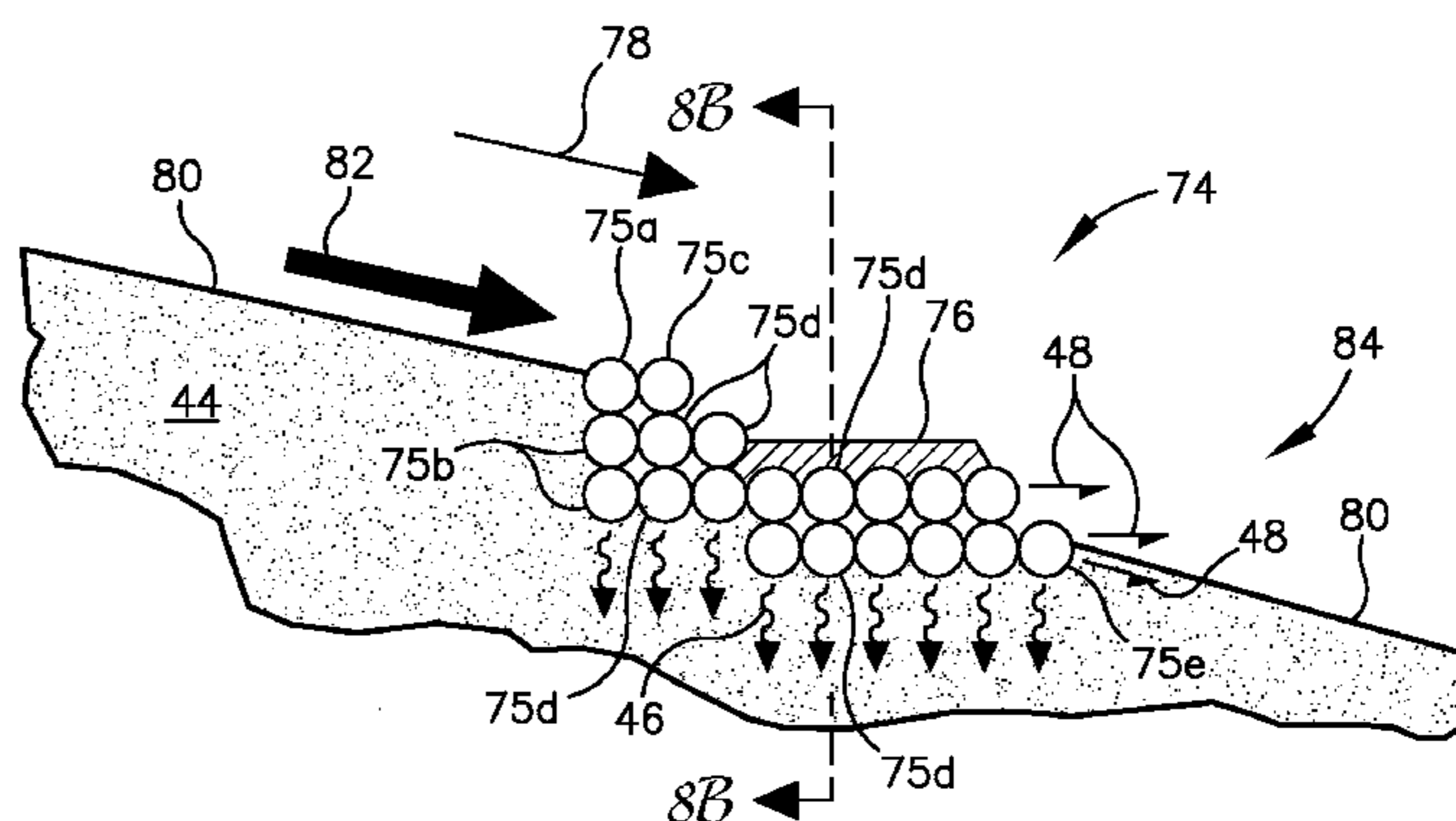
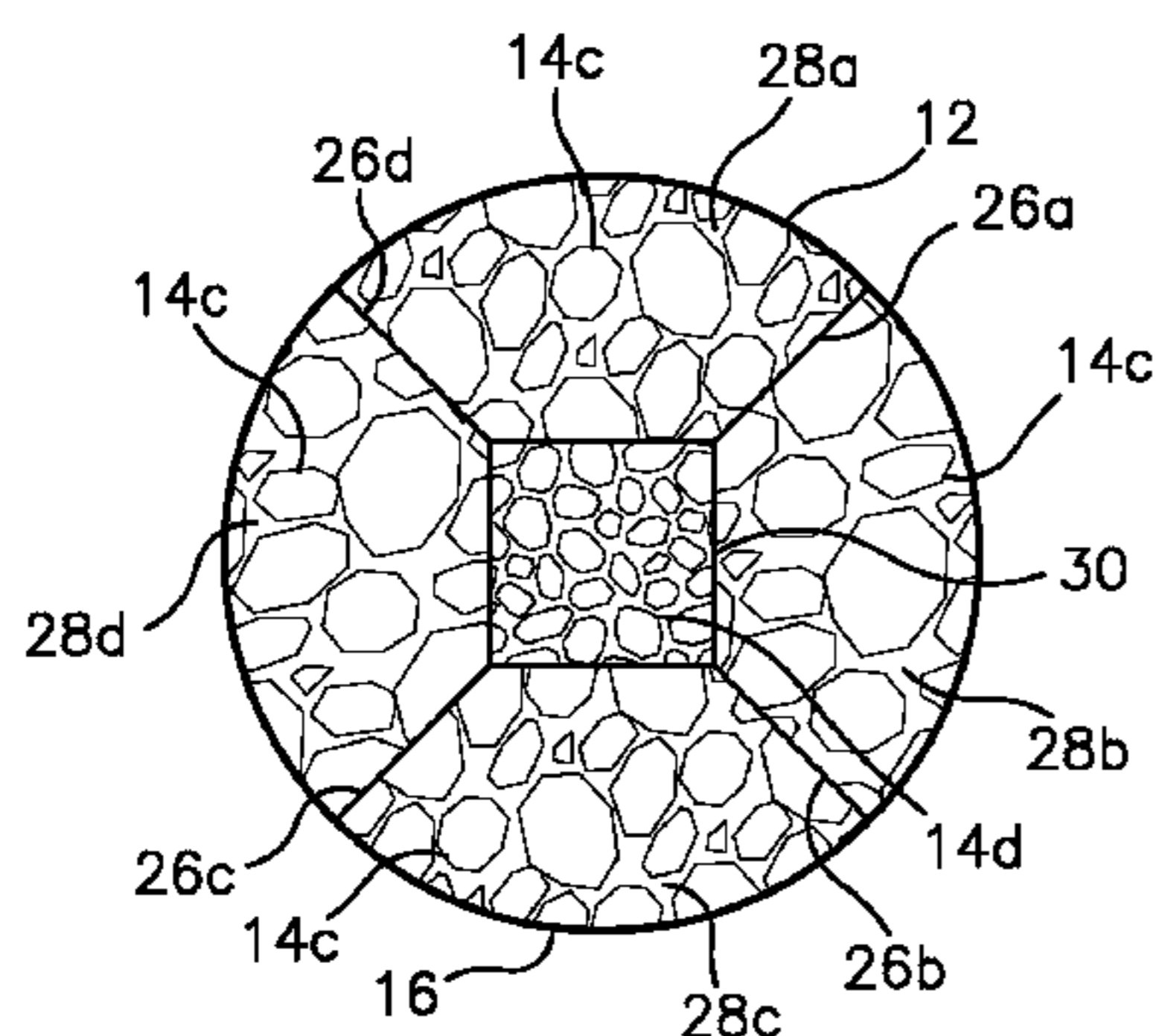

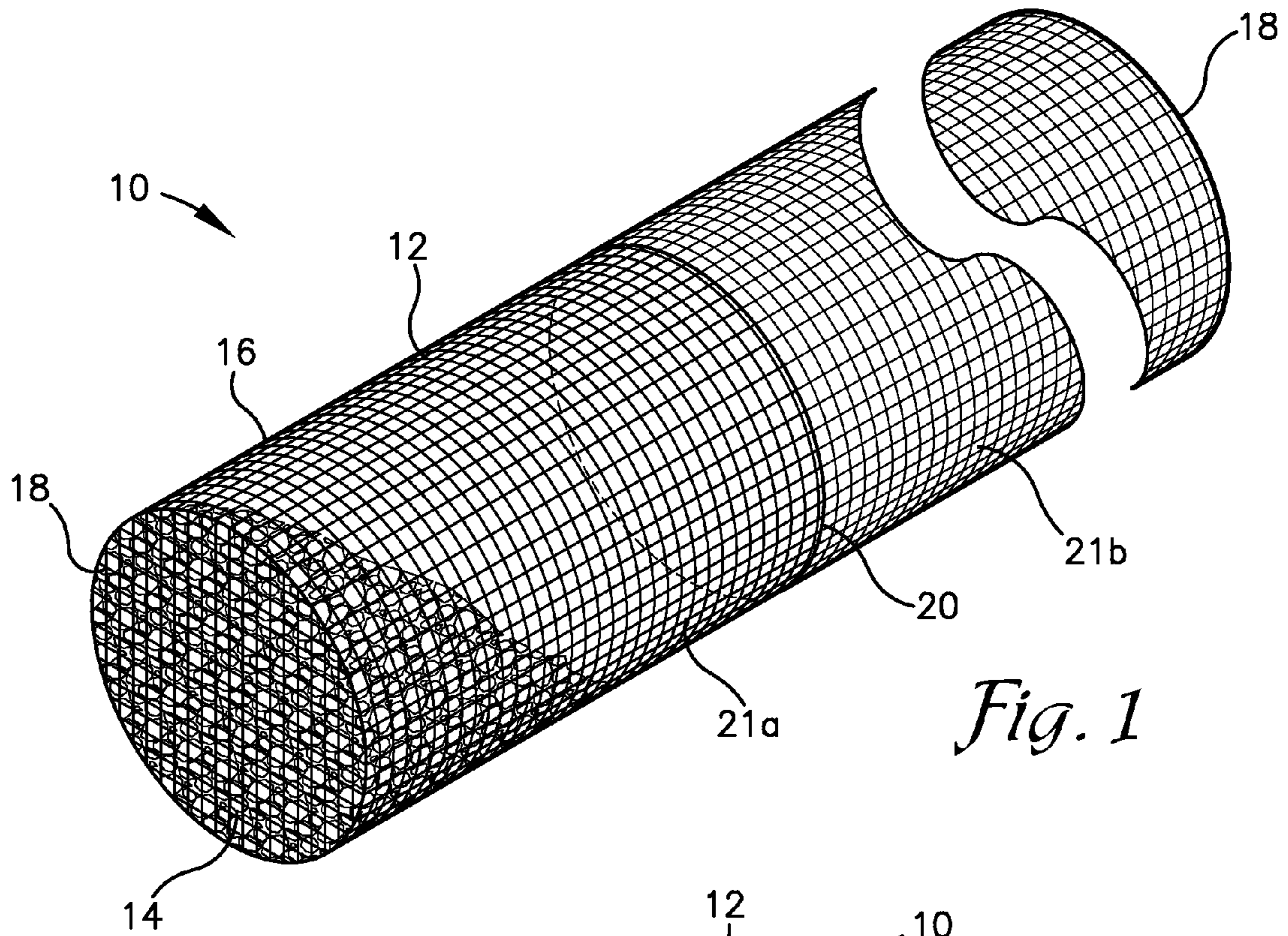

Fig. 1

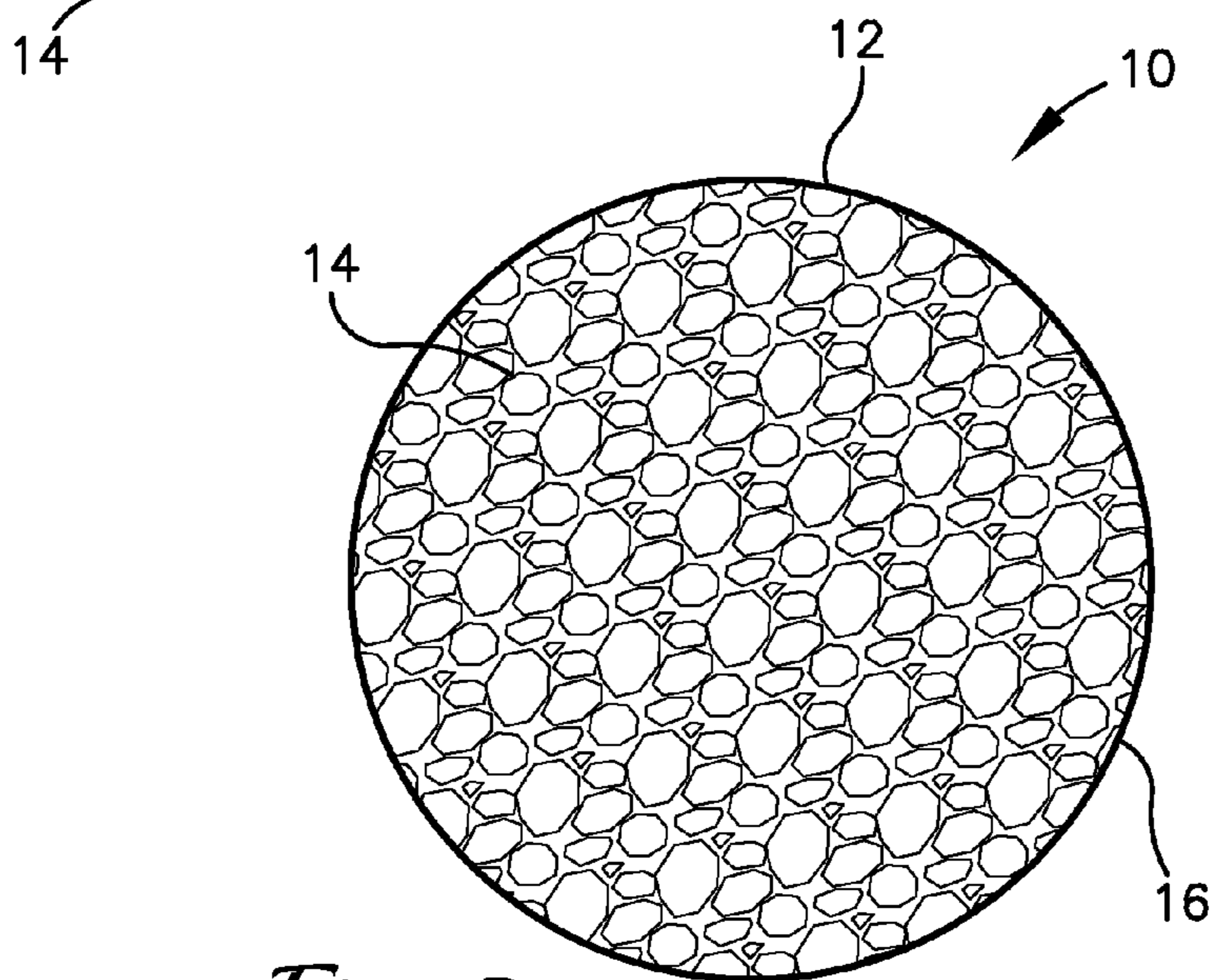

Fig. 2

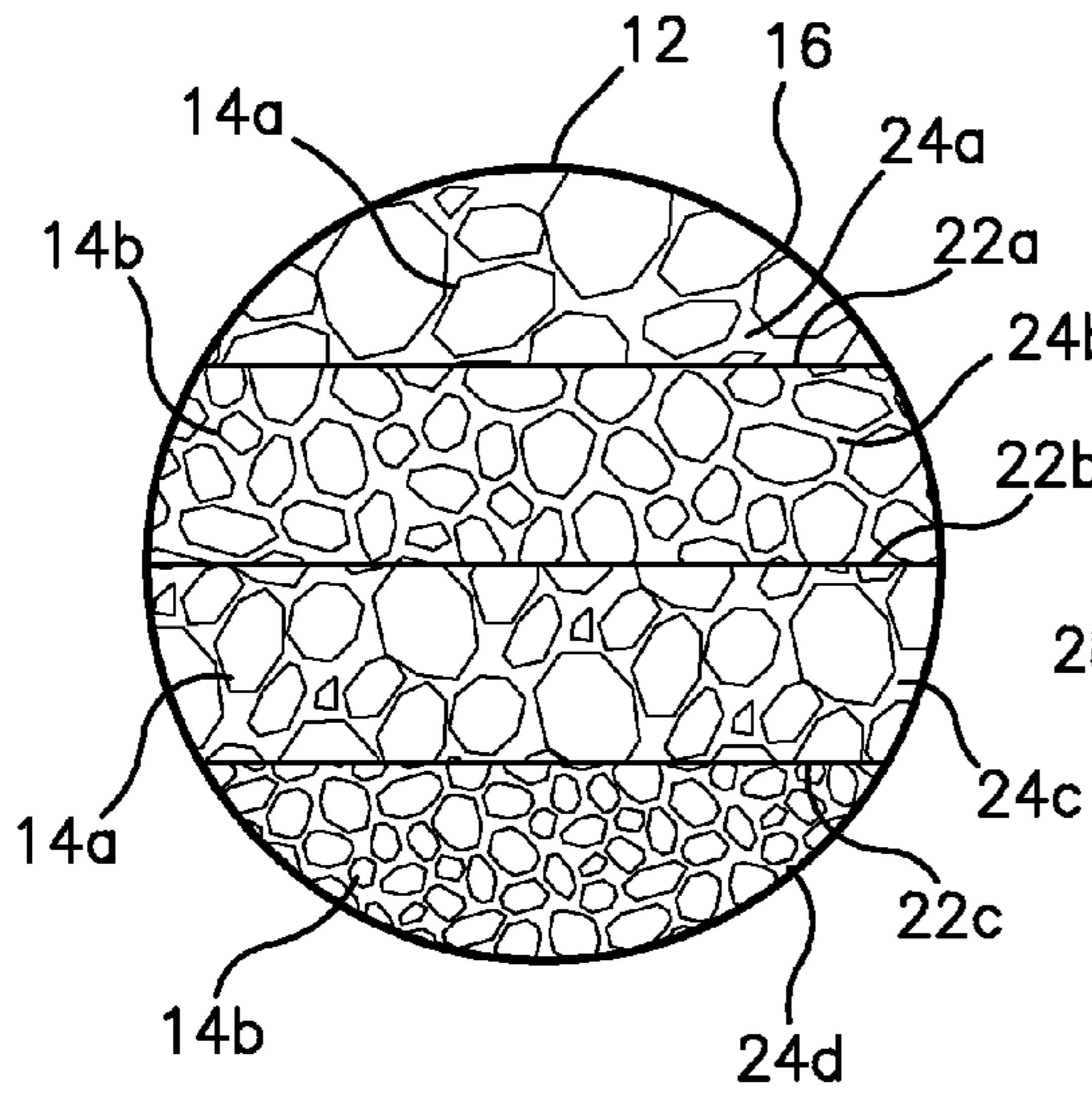

Fig. 3

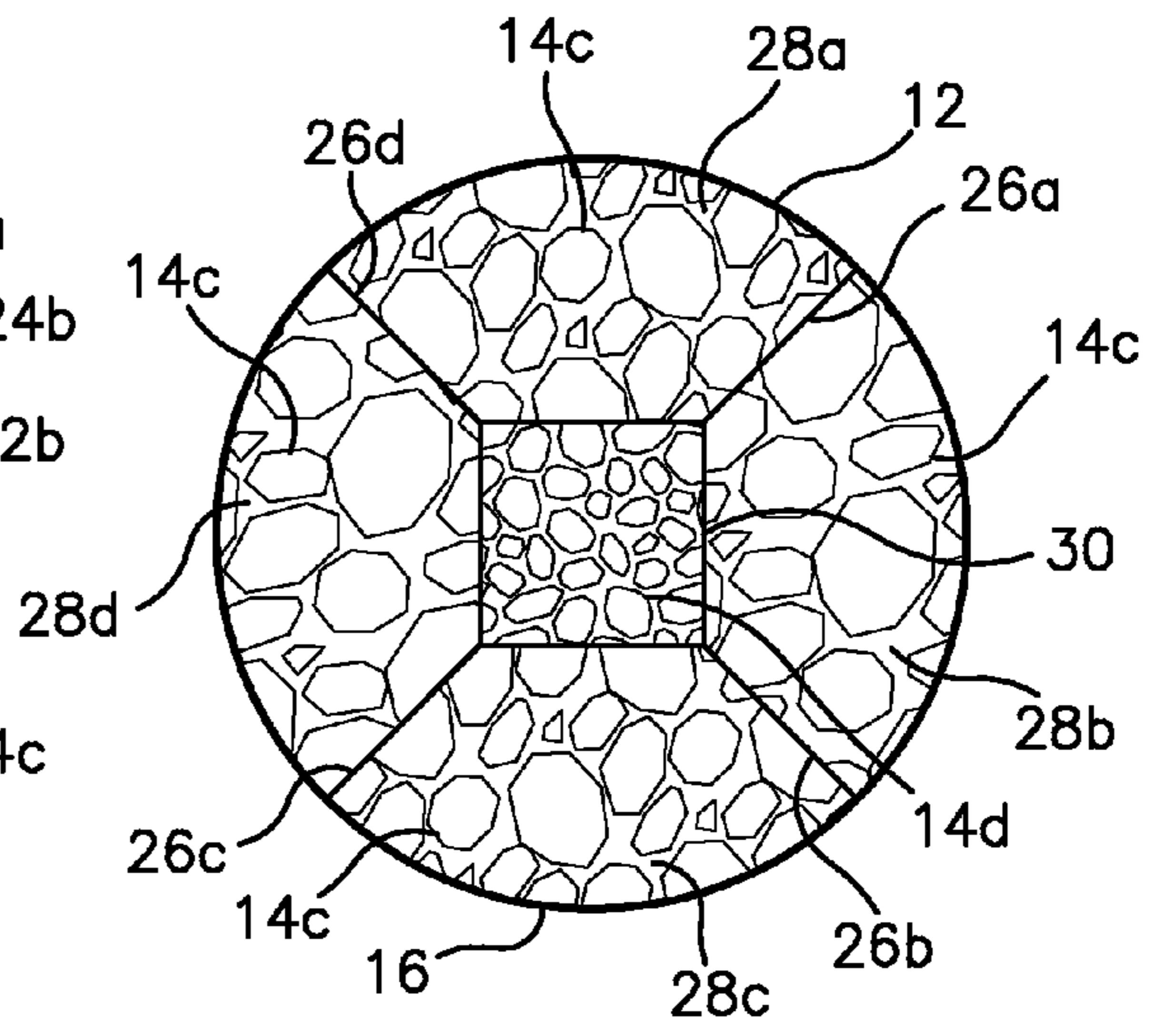

Fig. 4

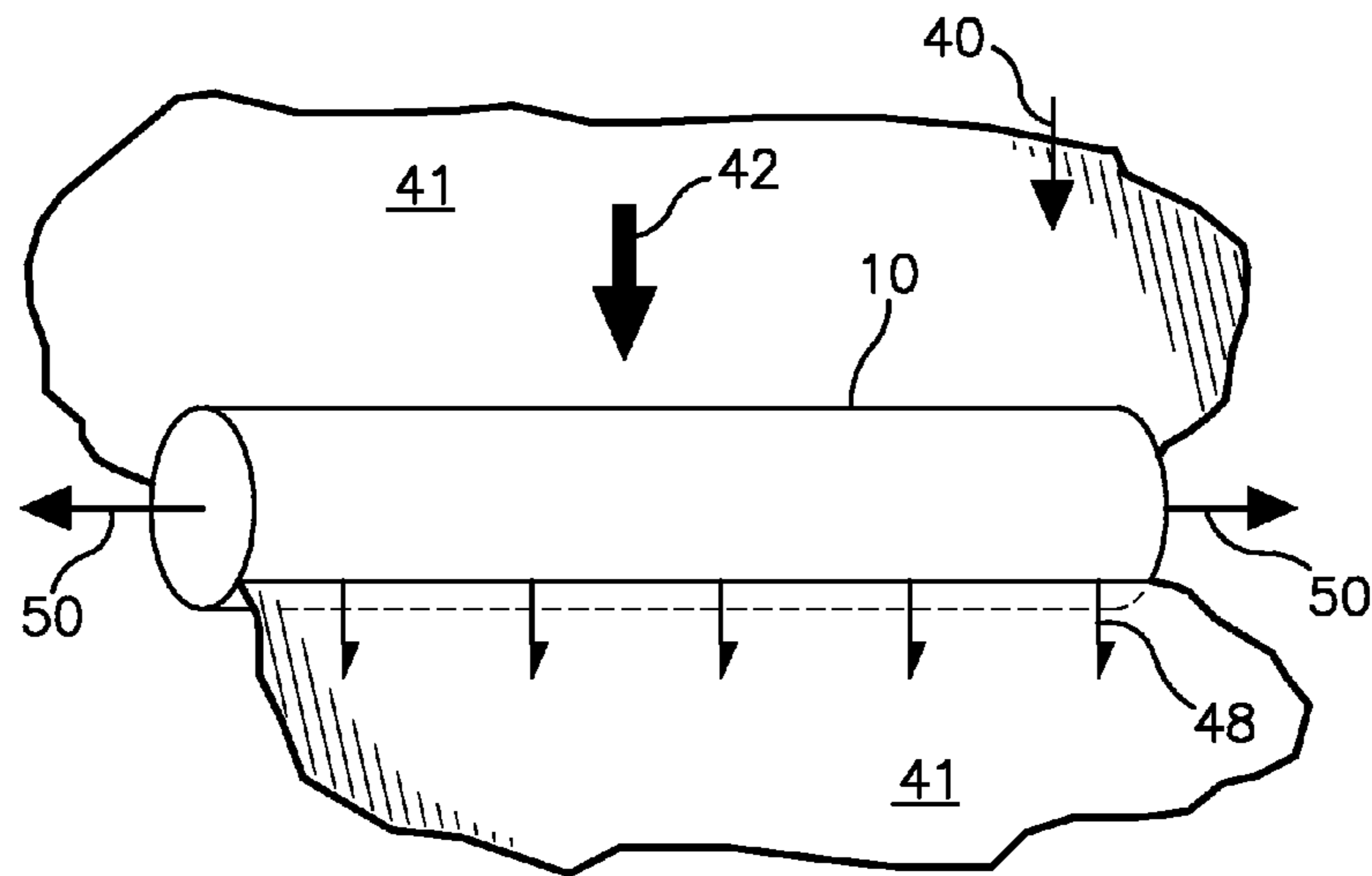
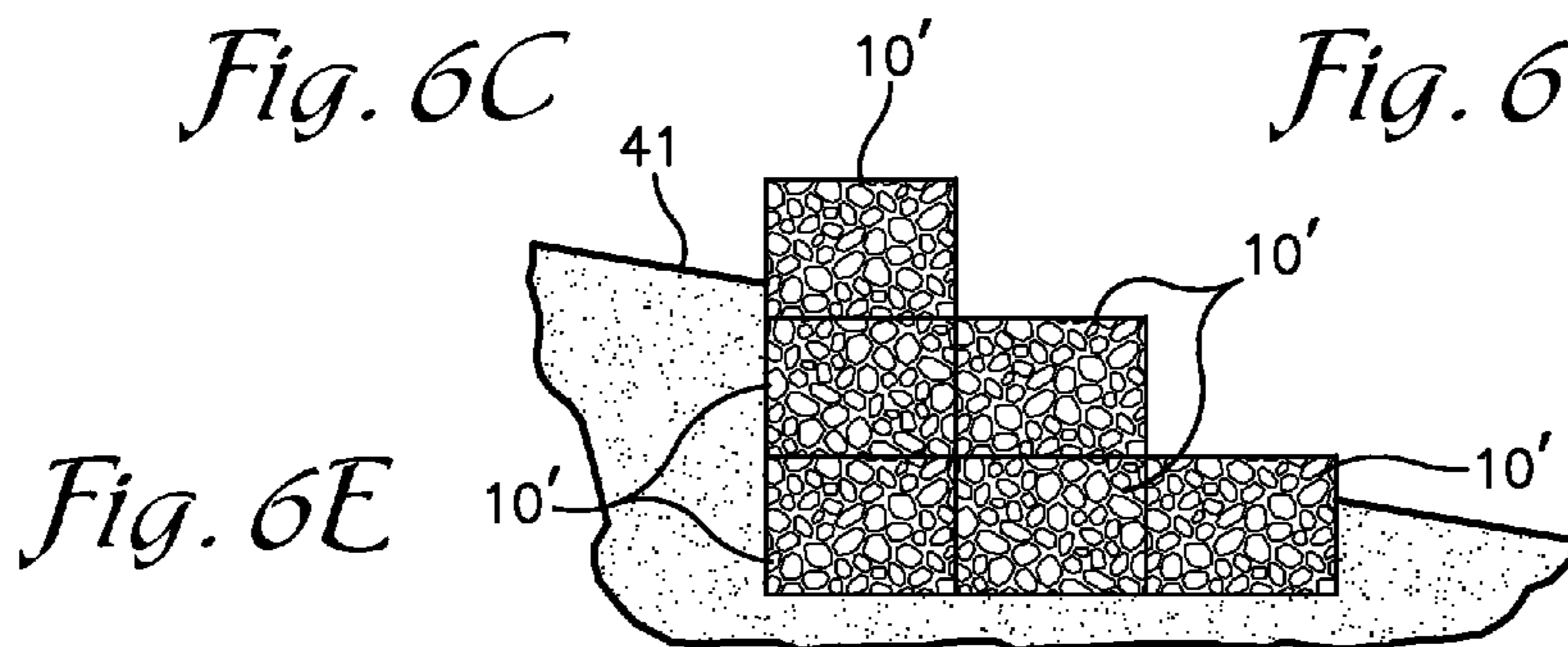
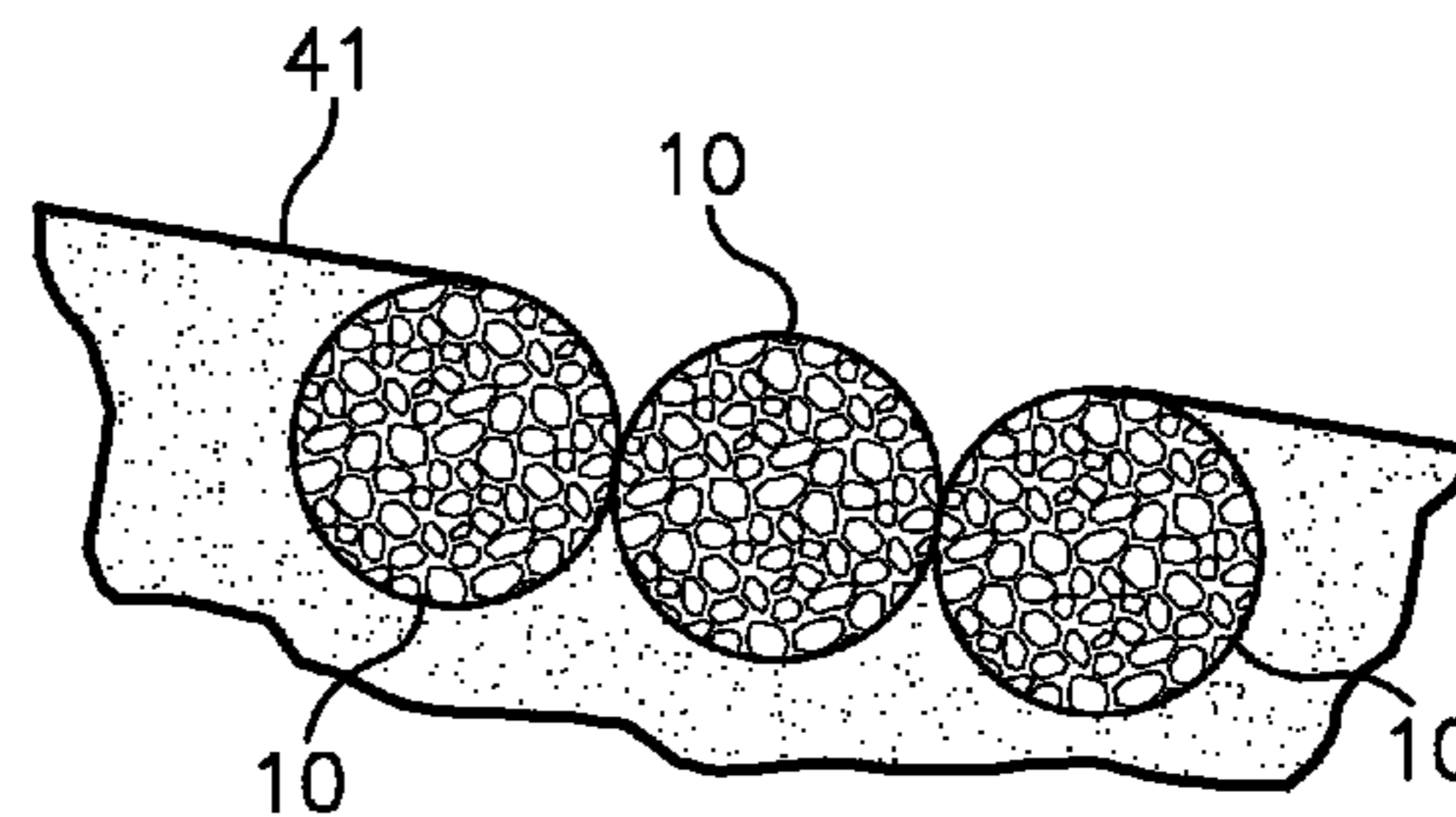
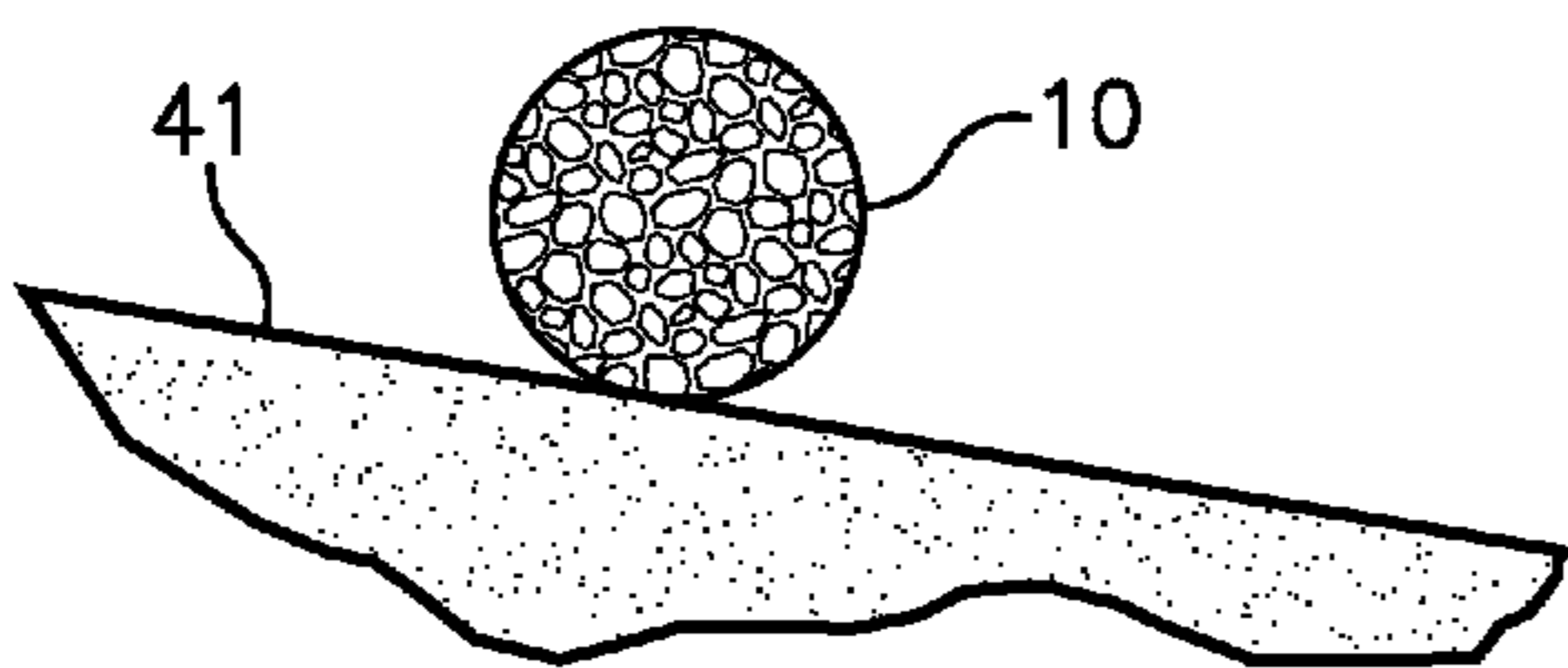
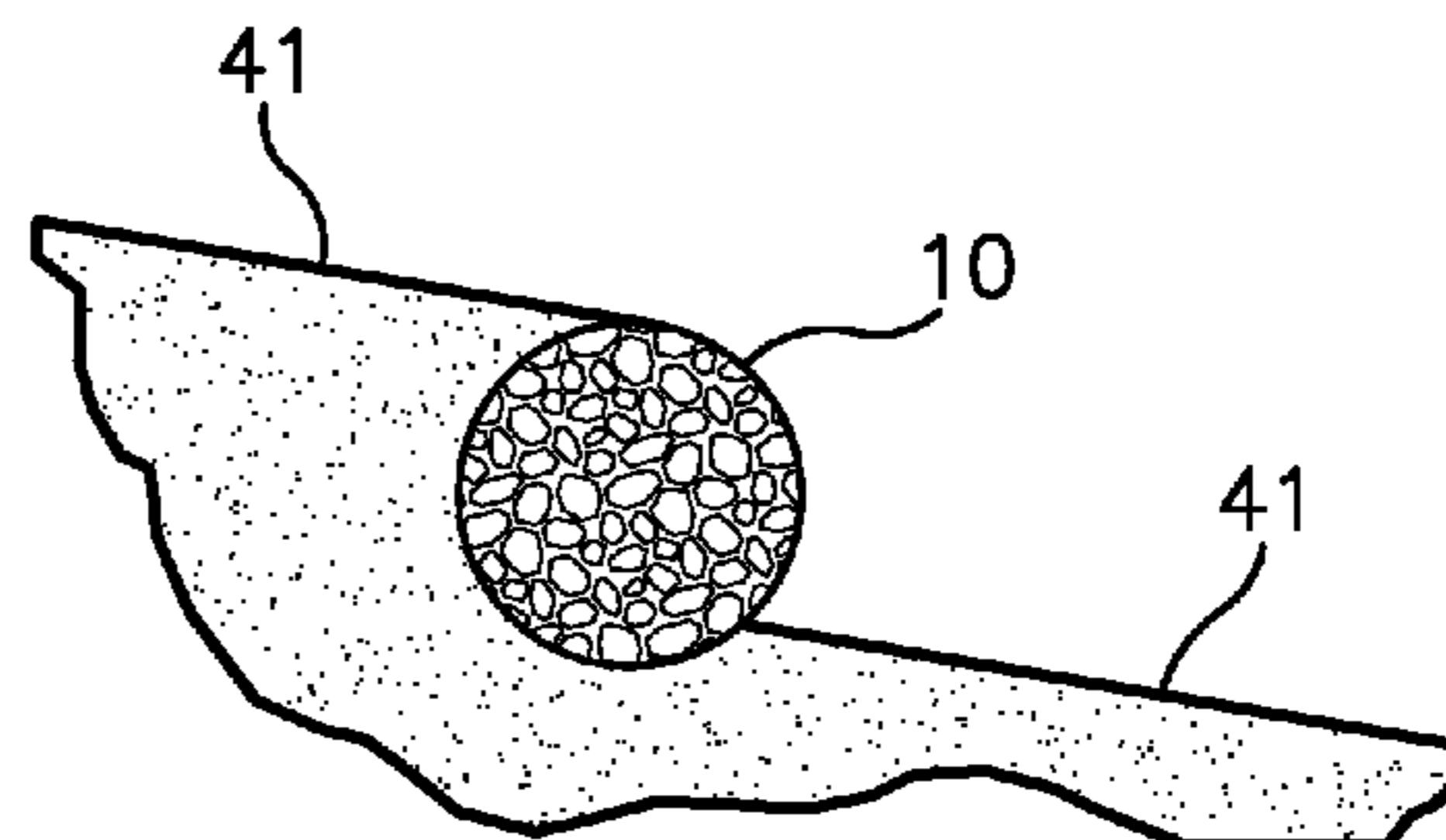
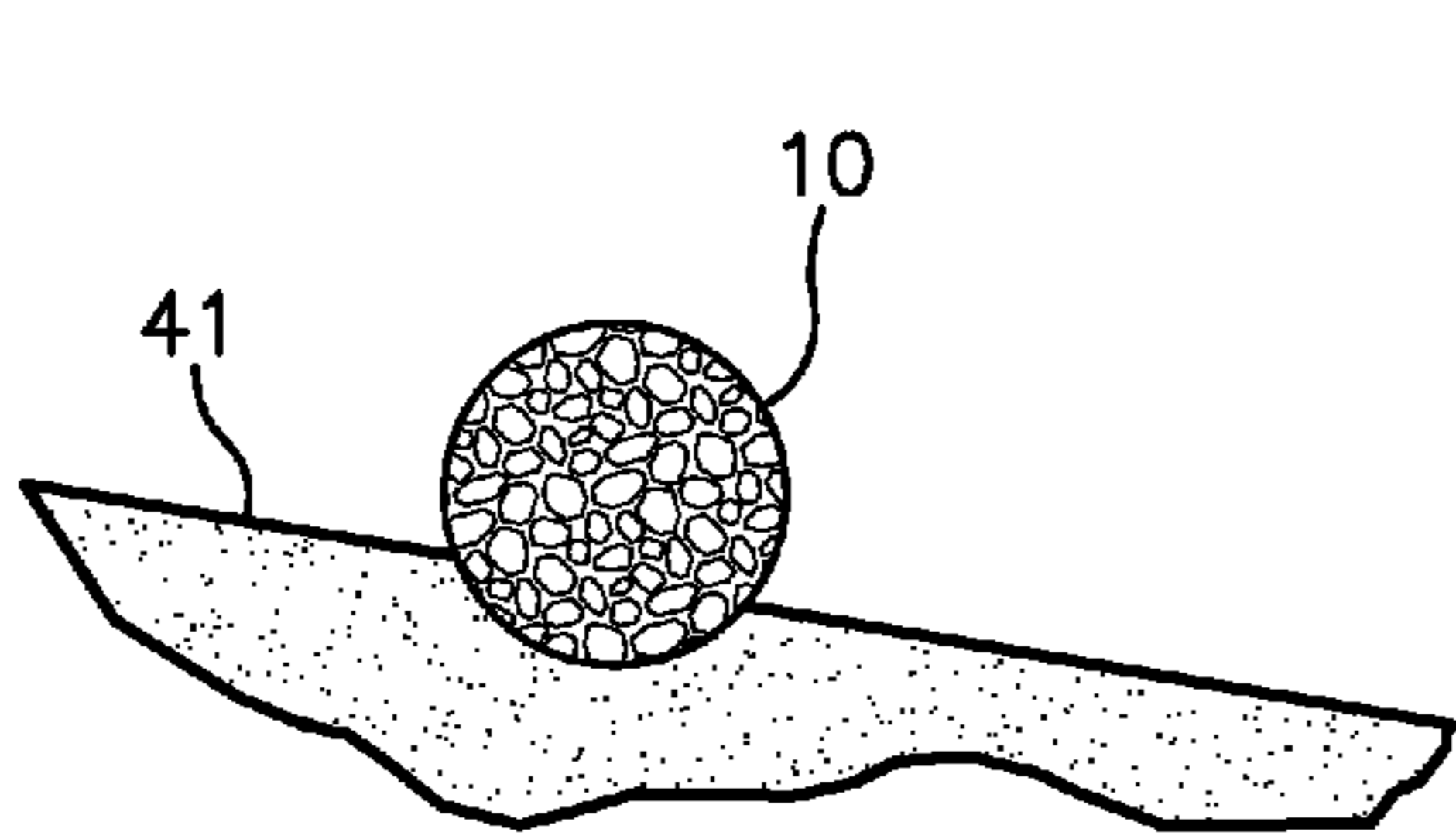
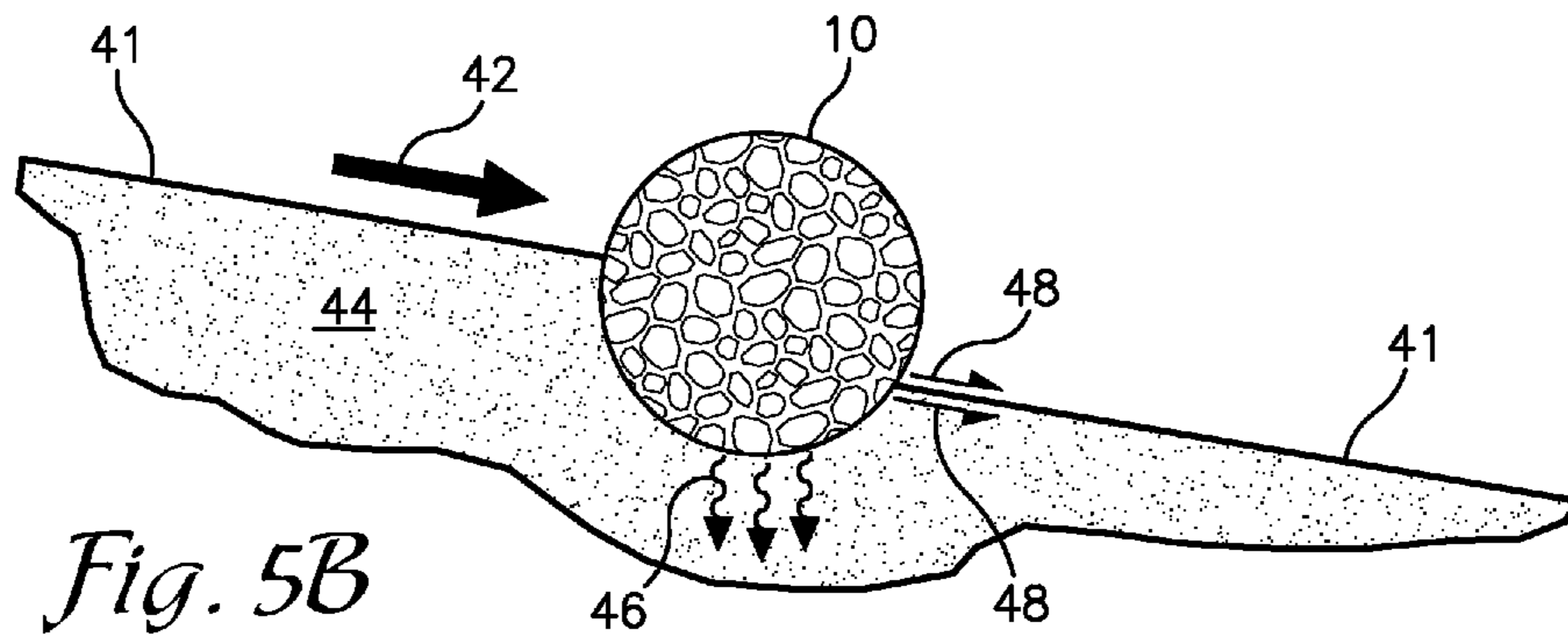

Fig. 5A



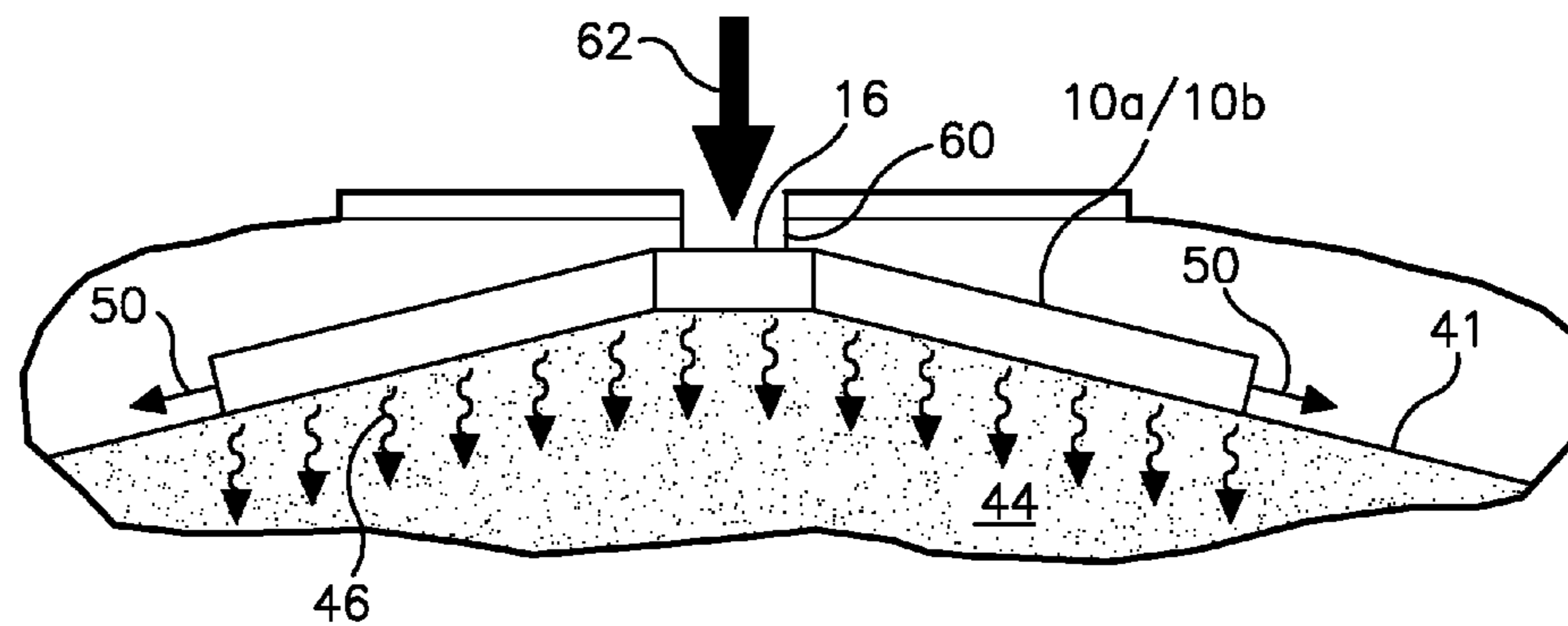
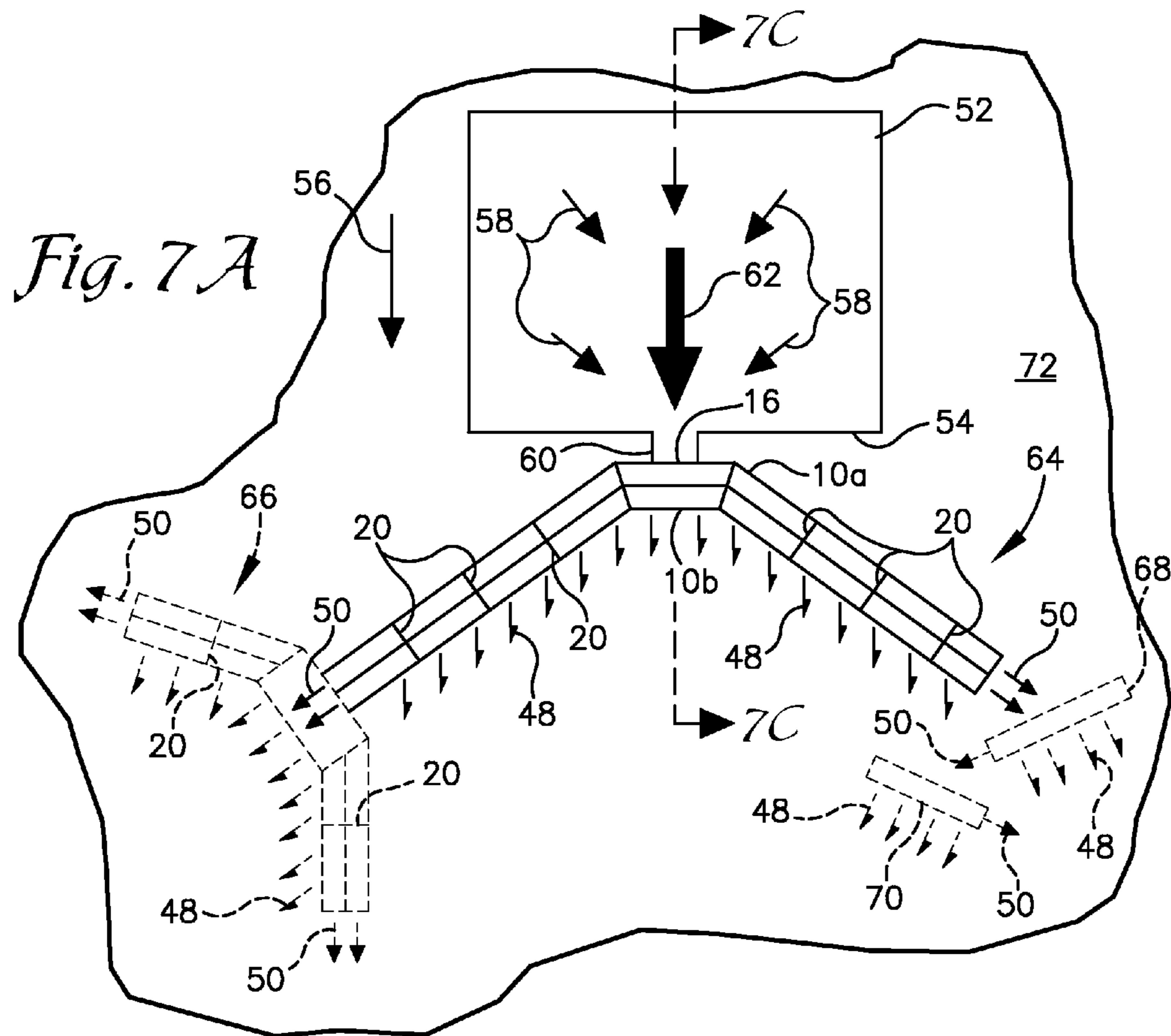

Fig. 7B

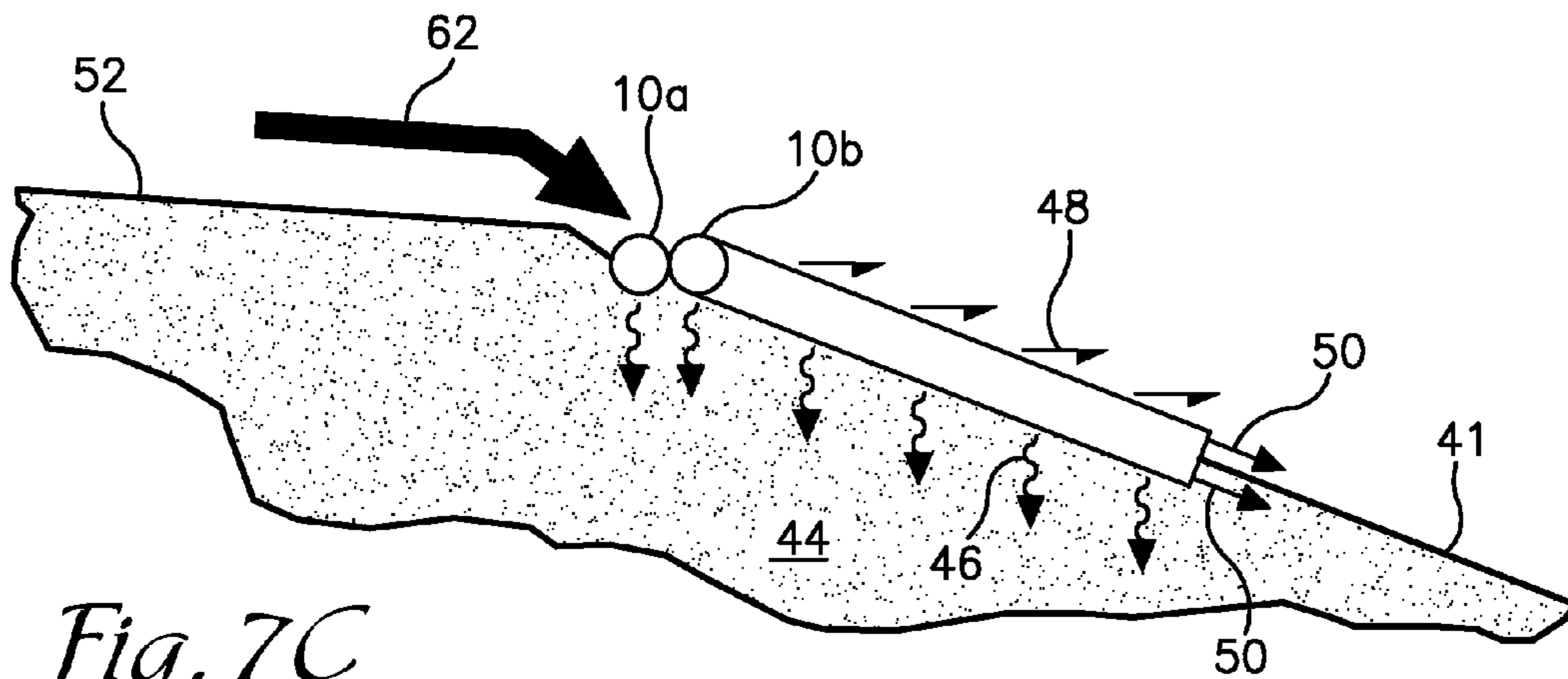

Fig. 7C

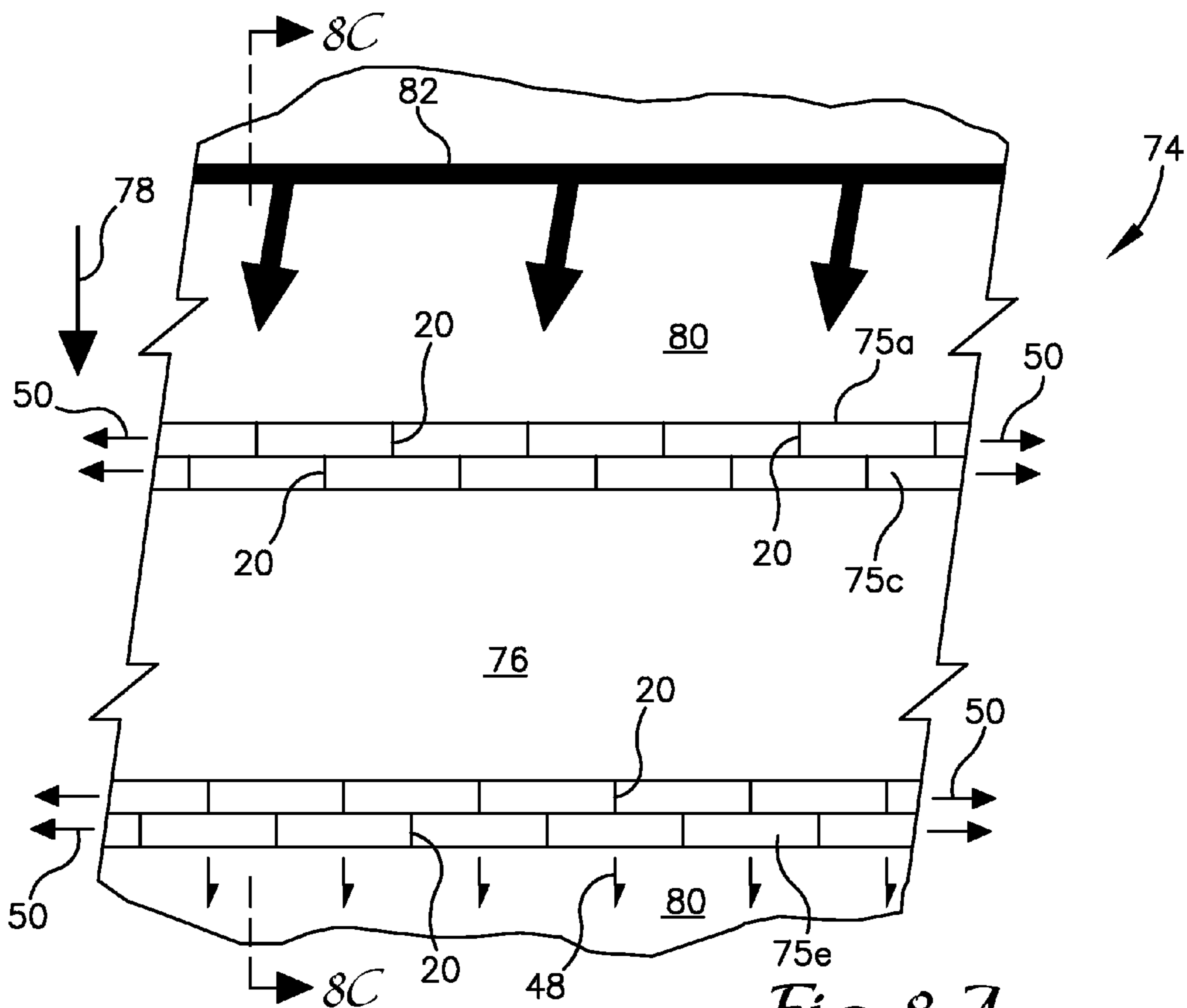
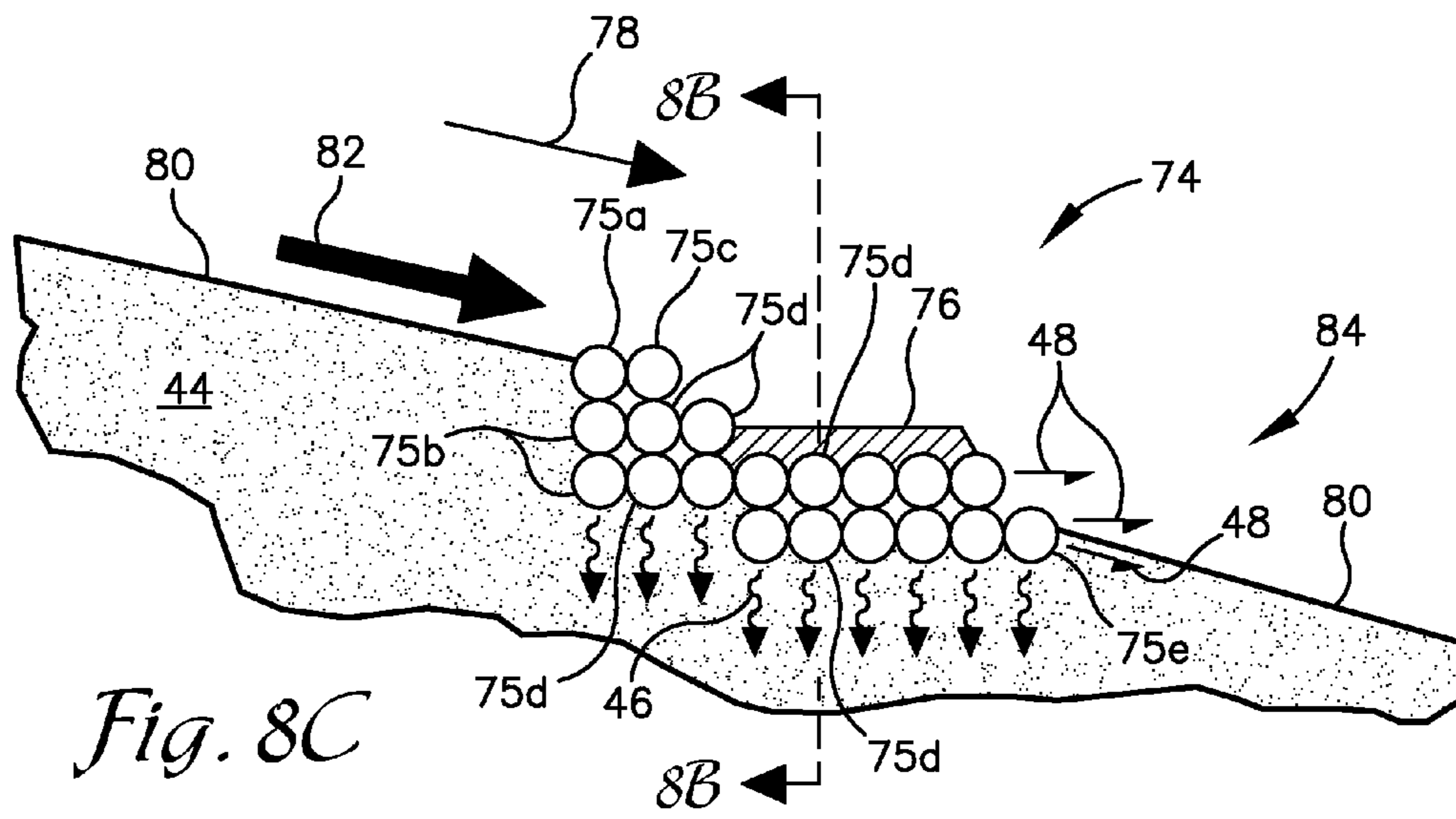
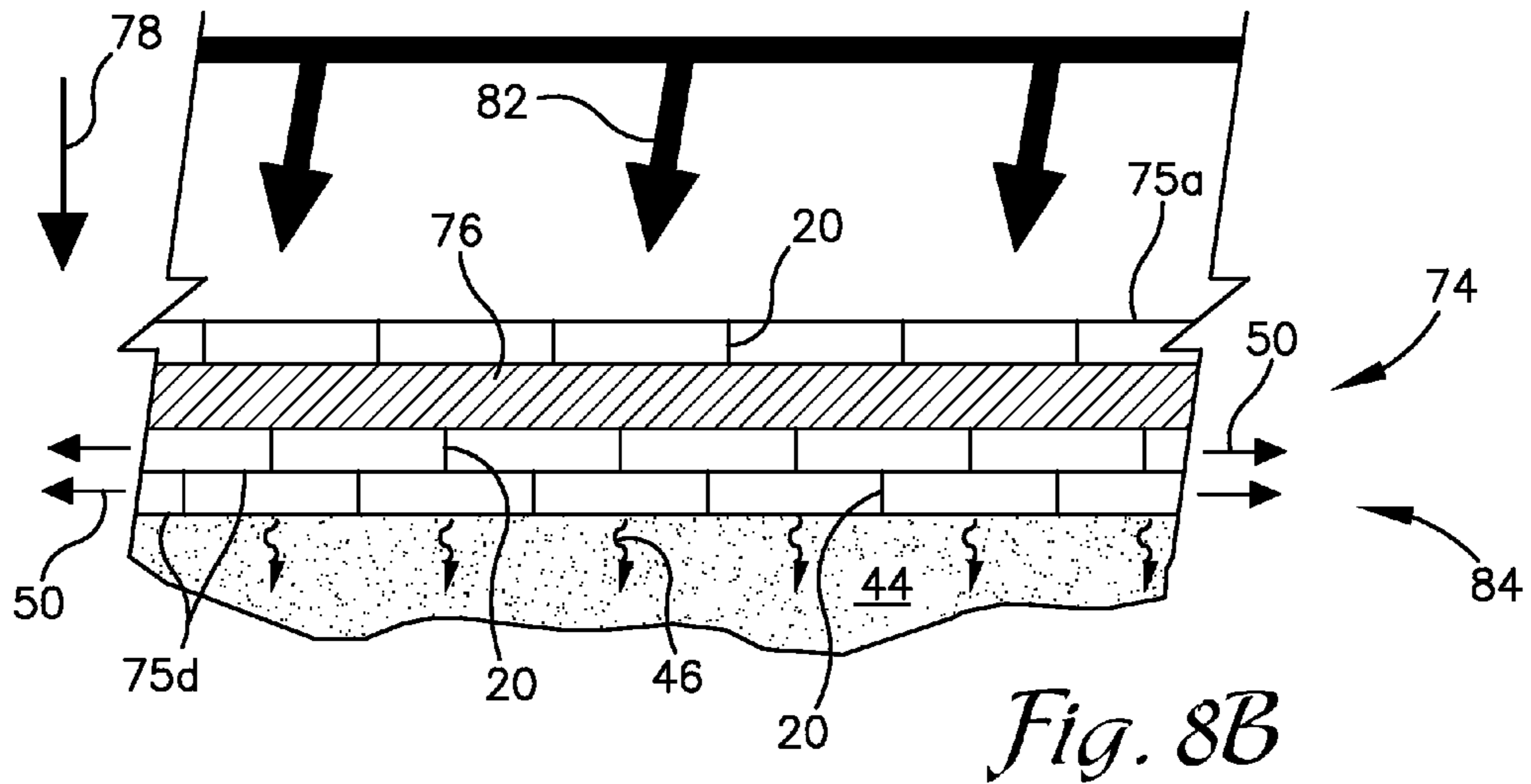

Fig. 8A



STORM WATER REDISTRIBUTION DEVICE**CROSS-REFERENCE TO RELATED APPLICATIONS**

This application claims priority to U.S. Provisional Patent Application No. 61/849,206, filed Jan. 22, 2013, the disclosure of which is hereby incorporated herein in its entirety by reference.

BACKGROUND

As various parcels of land are developed to create residential neighborhoods, shopping centers, and the like, pervious land covers like vegetation and undisturbed soil are replaced with impervious land covers, such as pavement and rooftops. These impervious surfaces prevent the natural infiltration of precipitation and result in increased storm water runoff. As storm water runoff flows off of a developed location and ultimately to a stream or other body of water, it can physically cause erosion and move soil particles, as well as dissolve and transport chemicals from the land surface to the body of water.

The U.S. Environmental Protection Agency (EPA) and state departments of natural resources/environmental protection are concerned with nonpoint source (NPS) pollution. NPS pollution is that component of water pollution that comes from the transport of materials on the land surface to a receiving stream via storm water runoff. With NPS pollution, there may be multiple pollutants that come from multiple surface locations under the jurisdiction of multiple landowners. One of these NPS pollutants is sediment. Sediment can be generated from the land surface over which the storm water runoff travels as well as from the bed of the stream channel through which the water is transported. Nonpoint source pollutants are responsible for many stream segments not meeting their water quality criteria.

The EPA now requires post-construction controls under its National Pollutant Discharge Elimination System (NPDES) Phase II storm water requirements. Post-construction controls, as incorporated into municipal ordinances and frequently called best management practices (BMPs), often require the location of buffer strips or stream buffers between the development and the stream in an effort to slow down and allow infiltration of the runoff before it reaches the stream, in addition to allowing sediment to drop out. The mechanism for this reduction in velocity is the hydraulic roughness of the vegetative cover of the buffer as the water travels in the form of overland flow. However, the storm water runoff from a development, even as small as a parking lot, often exits the development at a single concentrated location. There is thus no opportunity to take advantage of the benefits of overland flow and the resulting infiltration.

Stream buffers are among the very popular BMPs. With a stream buffer, a strip of land along a stream is precluded from development. With development, there are two major impacts. The first impact is the generation of additional volume of storm water runoff because of the increase in impervious surfaces. The second impact is the increase in NPS pollutants (e.g., sediment, nutrients, petroleum products, heavy metals) that results from the activities associated with development. The role of stream buffers is to slow the velocity of flow in order to physically allow solid materials to settle out and to increase storm water infiltration. Infiltration into the subsurface promotes "treatment" within the soil matrix. Infil-

tration results in less water arriving at the stream from the surface and reduces the potential for stream erosion with its many subsequent problems.

The expected performance of a buffer is associated with the expected condition of overland flow—slow, shallow flow that occurs over a large surface area. As overland flow progresses from higher to lower locations, the natural topography helps to concentrate flow into larger and larger channels with subsequent increases in velocity. The result of the concentration is the reduction in sedimentation and infiltration and the production of gullies downstream of any kind of storm water discharge location.

In order to make the requirement for buffers more acceptable, EPA documents tout buffers as linear parks, within the continuum from wooded areas adjacent to a stream through a brushy section, and linking to the grassed areas often associated with developed land. These natural areas could potentially increase property values and make up for the lost development areas. A linear park might be provided with walking paths, or such paths might develop organically from use by landowners and neighbors. Unfortunately, paths would exacerbate the natural process of flow concentration that short circuits the performance of the buffers.

What is needed, then, is a mechanism to return concentrated storm water runoff to the distributed overland flow condition to promote sedimentation and infiltration in compliance with EPA requirements and intentions. Increased sedimentation and infiltration will improve the effectiveness of buffers, even as paths help to make buffers more publically acceptable. Effective storm water management also prevents the destructive and costly impacts of gully and stream bank erosion, both of which can undermine expensive infrastructure. To accomplish this redistribution, a device is needed that introduces enough headloss to slow down the water and then allows it to spread out.

Current practice for managing concentrated flow, as from a parking lot, is to line the initial portion of the receiving vegetated channels with riprap or related products. The roughness of the riprap induces headlosses and armors the drainage channel to reduce erosion as the water travels to a stream, but does not serve to promote infiltration or sediment settling. Much opportunity remains for storm water management devices in order to service these regulatory drivers, even as the requirements become more stringent and more broadly applicable.

SUMMARY

Embodiments of the invention are defined by the claims below, not this summary. A high-level overview of various aspects of the invention are provided here for that reason, to provide an overview of the disclosure, and to introduce a selection of concepts that are further described in the Detailed-Description section below. This summary is not intended to identify key features or essential features of the claimed subject matter, nor is it intended to be used in isolation to determine the scope of the claimed subject matter. In brief, this disclosure describes, among other things, a storm-water redistribution device and methods for producing headloss in and redistribution of storm-water runoff and other fluid flows.

The storm-water redistribution device comprises a generally tubular, porous enclosure having one or more particulate media disposed therein. The device is configured to intercept an originating fluid flow, produce headloss in the flow, and to redirect or redistribute the flow into one or more subsequent flow types including: Type 1 or vertical flow, comprising

3

infiltration of the fluid into the subsurface; Type 2 or transverse flow, comprising overland or infiltrating flow of the fluid transverse to the length of the device; and Type 3 or longitudinal flow, comprising flow through the device and parallel to the length of the device. The headloss and redirection of the originating flow provided by the device reduces the velocity of the flow to increase subsurface infiltration of the resulting flows. Thereby, upon exiting the device, the ability of the fluid to retain and carry contaminants is diminished and the filtration of the fluid by the subsoil is increased.

The enclosure is preferably formed from a geotextile fabric comprised of a flexible mesh, netting, or other fluid-permeable material configured to enable infiltration of fluids into the device. The enclosure includes a generally elongate, tubular form and may include one or more transverse or longitudinal partitions therein. The partitions are configured to retain the particulate media within a particular location within the enclosure.

The particulate media comprise one or more aggregates, pebbles, rocks, sand, fibers, or other particulate materials. The particulate media is graded to provide a particular size or range of sizes and surface characteristics configured to produce a desired flow of fluid through respective regions of the device.

The storm-water redistribution device is installed across a path of the originating flow of storm water such that the originating flow is obstructed by contact with a sidewall of the device. The originating flow infiltrates into the device through the fluid-permeable enclosure to contact the media disposed therein. Flow through the device is obstructed by the media which is configured and located to slow the velocity of the flow and to divert the fluid in one or more directions. A portion of the fluid is diverted generally vertically downward to exit the device and infiltrate into the subsurface. A second portion of the fluid passes through the device to exit an opposite sidewall as overland flow but at a reduced velocity or as subsurface infiltrate. A third portion of the fluid is directed along the length of the device toward an end thereof. The third portion can exit an end of the device as overland flow or as subsurface infiltrate having a reduced velocity, or the third portion can be transferred to a subsequent storm-water redistribution device to provide further headloss and redistribution as necessary.

DESCRIPTION OF THE DRAWINGS

Illustrative embodiments of the invention are described in detail below with reference to the attached drawing figures, and wherein:

FIG. 1 is a perspective view of a storm-water redistribution device depicted in accordance with an embodiment of the invention;

FIG. 2 is a cross-sectional, end elevational view of a storm-water redistribution device depicted in accordance with an embodiment of the invention;

FIG. 3 is a cross-sectional, end elevational view of another storm-water redistribution device having a plurality of layered longitudinal partitions disposed therein and depicted in accordance with an embodiment of the invention;

FIG. 4 is a cross-sectional, end elevational view of a storm-water redistribution device having a plurality of longitudinal partitions forming compartments within the device depicted in accordance with an embodiment of the invention;

FIG. 5A is a top plan view of a storm-water redistribution device depicting redistribution of an originating flow in accordance with an embodiment of the invention;

4

FIG. 5B is an end elevational view of the storm-water redistribution device of FIG. 5A depicting redistribution of an originating flow in accordance with an embodiment of the invention;

FIGS. 6A-E are schematic end elevational views of various exemplary installation configurations of storm-water redistribution devices depicted in accordance with embodiments of the invention;

FIG. 7A is a schematic top plan view of an installation of storm-water redistribution devices for control of runoff from a parking lot depicted in accordance with an embodiment of the invention;

FIG. 7B is a schematic front elevational view of the installation of storm-water redistribution devices of FIG. 7A;

FIG. 7C is a cross-sectional side view of the installation of storm-water redistribution devices of FIG. 7A taken along the line 7C-7C;

FIG. 8A is a schematic top plan view of an installation of storm-water redistribution devices along a trail depicted in accordance with an embodiment of the invention;

FIG. 8B is a sectional, elevational view of the installation of storm-water redistribution devices of FIG. 8A taken along the line 8B-8B depicted in FIG. 8C; and

FIG. 8C is a cross-sectional, end elevational view of the installation of storm-water redistribution devices of FIG. 8A taken along the line 8C-8C.

DETAILED DESCRIPTION

The subject matter of select embodiments of the invention is described with specificity herein to meet statutory requirements. But the description itself is not intended to necessarily limit the scope of claims. Rather, the claimed subject matter might be embodied in other ways to include different components, steps, or combinations thereof similar to the ones described in this document, in conjunction with other present or future technologies. Terms should not be interpreted as implying any particular order among or between various steps herein disclosed unless and except when the order of individual steps is explicitly described.

Embodiments of the invention are described herein with respect to applications associated with storm-water runoff, however such is not intended to limit embodiments of the invention. Embodiments might also be employed for producing headloss and/or redistribution of non-storm-water related fluid flows like, for example, and not limitation, commercial chemical or fluid spills or discharges, residential drainage applications, creeks, rivers, and pond or lake runoff, among others.

With reference now to FIGS. 1 and 2, a storm-water redistribution device 10 is described in accordance with an embodiment of the invention. The device 10 comprises an elongate, generally tubular enclosure 12 with a volume of one or more particulate materials 14 disposed therein. The enclosure 12 is preferably comprised of a generally flexible, geotextile or geosynthetic fabric. The fabric can be a mesh, netting, felt, or other material formed from one or more plastics, polyesters, polypropylenes, polyethylenes, rayons, nylons, cotton, or the like that are woven, sewn, knitted, extruded, needle punched, perforated, or heat bonded, among others. The construction of the fabric provides pathways through which fluids can permeate through the fabric. The fabric is configured with sufficient fluid-permeability to enable a desired level of infiltration of fluid, e.g. storm water, through the fabric and into the device 10. The permeability of the fabric may be configured to restrict passage of particulate materials carried by the fluid through the fabric. Preferably,

5

the enclosure fabric at least partially filters contaminant particles suspended in the fluid to decrease sedimentation of the contaminants within the device **10**. The enclosure **12** includes an annular sidewall **16** with a transverse end wall **18** disposed at each end thereof. As depicted in FIGS. **1** and **2**, the enclosure **12** has a generally circular cross-sectional shape, but the enclosure **12** may take other forms, such as, ovate, polygonal, or curvilinear. The end walls **18** span across the open ends formed by the sidewalls **16** to fully enclose the interior of the enclosure **12**. The end walls **18** can be coupled to the sidewall **16** by one or more of sewing, welding, gluing, or the like. In an embodiment, one or more of the end walls **18** are not provided, and the sidewall **16** is gathered or folded toward the central longitudinal axis of the enclosure **12** and secured in place to enclose the end of the enclosure **12**.

The enclosure **12** can be constructed to provide the device **10** with any desired dimensions, but preferably has a length that is substantially greater than its width. In an embodiment, the device **10** has a length between approximately 5 and 100 feet and a transverse width of approximately 6 to 18 inches or preferably has a length of approximately 10 feet and a diametrical width of approximately 12 inches. The device **10** may be provided with dimensions that enable ease of handling, transport, and installation which may be completed manually or using construction equipment including loaders, lifts, and the like.

The enclosure **12** may include one or more transverse partitions **20** disposed therein. FIG. **1** depicts a transverse partition **20** disposed interior to the enclosure **12** and dividing the interior of the enclosure **12** into separate segments **21a**, **21b**. The transverse partitions **20** divide the interior of the enclosure **12** into a plurality of segments **21** of equal length or volume, or the transverse partitions **20** may divide the interior into a plurality of segments **21** of varied length or volume.

With additional reference to FIGS. **3** and **4**, one or more longitudinal partitions **22** might be provided. FIG. **3** shows longitudinal partitions **22a**, **22b**, **22c** extending between opposite sides of the sidewall **16** and along the length of the enclosure **12** to divide the interior of the enclosure **12** into a plurality of stratified compartments **24a**, **24b**, **24c**, **24d**. As depicted in FIG. **3**, the longitudinal partitions **22a-c** are generally planar and extend horizontally across the enclosure **12**, however the partitions **22** can be placed in any desired orientation and can be planar, angular, or curvilinear. The compartments **24** can be formed in any desired size, shape, and orientation by the partitions **22**. The longitudinal partitions **22** may also be configured to intersect and/or form additional compartments **24** within the enclosure **12**. For example, as depicted in FIG. **4**, longitudinal partitions **26a-d** are generally aligned along radii of the sidewall **16** and form a plurality of wedge-shaped compartments **28a-d**. The partitions **26a-d** also intersect and/or form a central compartment **30** within the interior of the enclosure **12**.

The transverse and longitudinal partitions **20**, **22**, **26** are formed from the same geotextile material that comprises the sidewall **16** and end walls **18** of the enclosure **12**. Or the partitions **20**, **22**, **26** can be formed from one or more different materials having different material properties, e.g. fluid-permeability. Further, each of the partitions **20**, **22**, **26** in a particular embodiment may be individually tailored to provide characteristics specific to each partition **20**, **22**, **26**. For example, as depicted in FIG. **3**, the partition **24a** might have greater fluid-permeability than the partition **24b** so as to enable greater vertical flow of fluid from the upper compartment **24a** to the next lower compartment **24b** while also promoting greater longitudinal flow within the compartment **24b**.

6

The partitions **20**, **22**, **26** aid to retain the particulate materials **14** within the respective segments **21** or compartments **24**, **28**, **30**. As such, the particulate materials **14** can be selectively positioned within the enclosure **12** to promote desired flow, headloss, or other characteristics. And the particulate materials **14** cannot be dislodged or relocated within the device **10** by the flow of fluid therethrough or by gravity acting on the device **10** when placed on a slope.

The particulate materials **14** preferably comprise one or more gravels, pebbles, aggregates, sands, plastics, or the like. The particulate materials **14** may be graded by average particle size to provide a volume of the material **14** in a respective segment **21** of a single particle size (uniformly graded) or one or more ranges of sizes (well graded or gap graded).

The device **10** is configured for permanent or long-term installation and thus the particulate materials **14** are preferably non-organic materials that will not readily degrade or decompose. In another embodiment, the device **10** can be configured for short-term use and may include decomposable or organic materials like wood shavings, wood pellets, clay, peat, rice hulls, compost, and waste materials, among others. Activated carbon, flocculants, chemical binders, and other materials configured to collect, react with, bind, or precipitate contaminants from the fluid can also be used. Organic, decomposable, and chemically active materials may cause sedimentation or precipitation of particles within the enclosure **12** which may shorten the useable lifespan of the device **10**.

The type and/or grade or grades of the particulate material **14** are selected to provide a desired headloss in a fluid flowing through a volume of the material **14** within the device. Characteristics, such as surface texture, e.g. smooth, rough, or porous, and overall shape are also selectable to tailor the headloss and flow diversion provided by the material **14**. The material characteristics and/or orientation of the particles thereof within the device **10** are further selectable to aid diversion of the fluid flow in desired directions. For example, elongate particles might be chosen and aligned lengthwise with the length of the device to induce type 3 fluid flow parallel to the length of the device.

Each of the segments **21** and compartments **24**, **28**, **30** can be filled with a single type and grade of particulate materials **14**, or the materials **14** can be selectively tailored to the flow and headloss characteristics desired in each of the segments **21** and compartments **24**, **28**, **30**. For example, as depicted in FIG. **3**, a larger, uniformly graded material **14a** might be disposed in compartments **24a** and **24c** to provide a low level of headloss to a fluid flow and to divert the fluid flow downward into compartment **24b** and **24d**, respectively, that include a smaller, well graded material **14b** that provides a greater level of headloss to the fluid. Or, as depicted in FIG. **4**, a well graded material **14c** might be disposed in compartments **28a** to provide sufficient headloss and filtration of a fluid flow while a larger, uniformly graded material **14d** is disposed in the central compartment **30** to enable greater flow of the fluid parallel to the length of the device **10** for redistribution of the fluid therealong. Although exemplary configurations of the materials **14** and compartments **24**, **28**, **30** are depicted and described herein, such is not intended to limit embodiments of the invention. Any of a variety of possible combinations and configurations of the materials **14** and compartments **24**, **28**, **30** may be employed in embodiments of the invention without departing from the scope described herein.

With reference now to FIGS. **5A** and **5B**, operation of the device **10** is described in accordance with an embodiment of the invention. The device **10** is configured for installation generally perpendicular to an overall downward slope

depicted, by an arrow 40, of a surface 41. The downward slope 40 causes storm water to form an originating flow, depicted by an arrow 42, flowing in the direction of the downward slope 40. The originating flow 42 can be dispersed across the surface 41 to be intercepted by the device 10 evenly along its length or characteristics of the surface 41, such as gullies, valleys, debris, curbing, or other natural or man-made features may concentrate the flow along smaller sections of the length of the device 10.

The originating flow 42 is intercepted by the device 10 and infiltrates into the device 10 through the sidewall 16 thereof. Impact with and infiltration through the sidewall 16 may provide some headloss to the flow. The flow next impacts the particulate materials 14 disposed in the enclosure 12 which further obstruct flow of the fluid in the downslope direction 40. The particulate materials 14 thus further reduce the flow velocity and direct the fluid toward one or more flow types—types 1, 2, or 3.

Type 1 flow comprises generally vertical flow of the fluid toward the surface and includes infiltration of the fluid into the subsurface 44, as depicted in FIG. 5B by squiggled arrows 46. Type 2 flow comprises transverse flow that may be overland flow, e.g. flow of the fluid along the top of the surface 41, or subsurface flow that infiltrates into the subsurface 44 and is depicted by single-headed arrows 48. The type 2 flow produced by the device 10 is preferably of such reduced velocity to be sufficiently further slowed by the surface 41 and groundcover thereon to transform into type 1 flow and infiltrate into the subsurface 44. Type 3 flow comprises flow interior to the device 10 and generally parallel to the length thereof; type 3 flow is depicted in the figures by closed-head arrows 50. Preferably, type 3 flow exists within the device 10 but is sufficiently slowed by the particulate materials 14 therein to transform the type 3 flow into type 1 or type 2 flow before exiting the device 10. However, some fluid may exit the end walls 18 of the device 10 as type 3 flow as shown by the arrows 50. Type 3 flow exiting the end walls 18 may flow onto the surface 41 as overland flow, infiltrate into the subsurface 44, or flow into a subsequent device 10 as described below.

The device 10 can be disposed or installed on the surface 41 in a variety of configurations for permanent or temporary use. As depicted in FIGS. 6A-E, the device 10 can be at least partially sunken into the surface 41 (FIG. 6A); backfilled so as to position an upslope portion of the surface 41 at an elevation substantially even with a top portion of the device 10 and a downslope portion substantially even with a bottom of the device 10 (FIG. 6B); or placed directly on top of the surface 41 (FIG. 6C). A plurality of the devices 10 might also be provided and arranged in side-by-side rows and/or stacked as depicted in FIGS. 6D and 6E. Such multiple-device installations can employ any of the positioning techniques depicted in FIGS. 6A-C among other configurations. Devices 10 of various cross-sectional configurations might also be used to aid positioning of the devices 10, as shown by the use of square cross-sectional-shaped devices 10' in FIG. 6E. Although, a variety of exemplary installation configurations are depicted and described herein, such is not intended to limit embodiments of the invention. Any of a variety of other installations might be employed and are understood as falling within the scope of embodiments of the invention described herein.

The devices 10 are preferably of sufficient weight to resist displacement caused by interception of the originating flow 42 when installed in any of the configurations depicted in FIGS. 6A-E. However, the device 10 may be anchored to the surface 41 by any means available in the art including, for example and not limitation, stakes, tethers, anchors, or the

like. In multiple device installations the devices 10 may be attached to one another by one or more fasteners, threads, ties, zip-ties, staples, welds, or the like.

Referring now to FIGS. 7A-C, an installation of the device 10 for control of storm-water runoff from a concentrated originating flow 62 produced by a parking lot 52 is described in accordance with an embodiment of the invention. An exemplary parking lot 52 having a curb 54 is described herein, but embodiments of the invention can be applied to any of a variety of similar flow-concentrating, impervious or semi-pervious, man-made or natural structures or surfaces without departing from the scope of embodiments of the invention described herein. The parking lot 52 has an overall downward slope depicted by arrow 56 that forms a flow of runoff 58 of storm-water that falls on the parking lot 52. The runoff 58 is diverted by the curb 54 toward an outlet 60 and thus forms a concentrated originating flow depicted by an arrow 62 that is directed by the outlet 60 toward an installation 64 of the device 10.

The installation 64 comprises one or more devices 10 disposed perpendicular to the slope 56 of the parking lot 52 and the outlet 60 to intercept the concentrated originating flow 62 therefrom. The installation 64 can be placed to abut the outlet 60, adjacent the outlet 60, or a distance downslope from the outlet 60. As depicted in FIG. 7A, the installation includes a pair of the devices 10 disposed side-by-side in a slightly arched or V-shaped arrangement in which the apex of the arch or V is aligned with the outlet 60. Although, two devices 10 are shown and described, other configurations are available. For example, a plurality of the devices 10 can be disposed end-to-end to form substantially the same configuration; the ends of such devices 10 can be coupled together by any available means, e.g. zip-ties, staples, stakes, threading, sewing, adhesives, welding, or the like or may remain uncoupled. Or multiple devices 10 can be stacked and/or laid side-by-side to provide a larger barrier for interception and diversion of the concentrated originating flow 62 as is necessary for particular site conditions.

The devices 10 depicted in FIG. 7A include a plurality of internal transverse partitions 20 disposed along the length thereof. The partitions 20 aid to retain the particulate materials 14 in the device 10 in desired locations during manufacturing, transport to an installation site, and installation of the device 10. The partitions 20 also retain the particulate materials 14 against movement that might result from flow of fluids through the device and gravity urging the materials 14 to move downslope.

In operation, as shown in FIGS. 7A-C, the concentrated originating flow 62 is received and intercepted by the sidewall 16 of the device 10a located on the upslope side of the installation 64. As described with respect to FIGS. 5A-B, the concentrated originating flow 62 infiltrates into the device 10a to form an internal flow that contacts the particulate materials 14 therein. Sediments, particulates, and other materials carried by the originating flow 62 are preferably substantially filtered out of the fluid by the enclosure 12 before infiltrating into the interior of the device 10a. Such filtration aids to prevent or reduce sedimentation within the device 10 that would reduce the effectiveness of the particulate materials 14 in slowing the internal flow and reduce the operating life of the device 10a.

Within the device 10a, the particulate materials 14 slow the internal flow velocity and divert the internal flow into type 1, type 2, and type 3 flows. The fluid is thus diverted into type 1 flow vertically downward to infiltrate into the subsurface 44 (as shown in FIG. 7B by arrows 46), along the length of the device 10a as type 3 flow (as depicted by arrows 50), and as type 2 flow to exit the opposite sidewall 16 of the device 10a

and to enter into a second device **10b** located downslope from the device **10a** or to infiltrate into the subsurface **44**. The flow of fluid entering the second device **10b** is similarly diverted into type 1, 2, or 3 flows and is provided with further reduction in velocity thereof.

Fluid exiting the second device **10b** as type 2 flow (shown by arrows **48**) may flow over the surface **41** as overland flow which is preferably further slowed by the surface **41**, such as by vegetated cover thereon, to transform to type 1 flow and infiltrate into the subsurface **44**. The fluid exiting the second device **10b** as type 2 flow may also or alternatively infiltrate into the subsurface **44**. Type 2 flow leaving the second device **10b** but not being further sufficiently slowed to transform to type 1 flow may eventually reach and combine with a stream, river, pond, or other body of water. Preferably, such residual flow is sufficiently decreased in both volume and velocity to have a negligible or greatly reduced impact on the receiving body of water. The decrease in velocity also aids to reduce or eliminate contaminate particles carried by the overland flow and thus reduces introduction of such contaminants to the receiving body of water.

The length of the devices **10a-b** are preferably configured to provide sufficient headloss and dispersion of the concentrated originating flow **62** that type 3 flow from the end walls **18** (shown by arrows **50**) of the devices **10a-b** is negligible or is of such reduced volume and velocity as to be non-deleterious overland flow. However, if the volume or velocity of the resulting type 3 flow is too great, subsequent installations **66**, **68**, **70** may be provided.

As shown in phantom lines in FIG. 7A, a subsequent installation **66** of the device **10** can be provided to intercept the type 3 flow leaving the end walls **18** of the devices **10a-b** and to further divert the flow downslope in a manner similar to that described above. The installation **66** can abut the end walls **18** so as to receive the type 3 flow directly. A subsequent installation **68** might also be provided spaced apart and downslope from the primary installation **64** so as to intercept type 3 and/or type 2 flows leaving the installation **64** as well as any additional flow produced by storm waters on the surrounding surface **72**. Spacing of the subsequent installation **68** from the primary installation **64** may allow the surface and groundcover thereon to at least partially slow and/or absorb a portion of the fluid before reaching the subsequent installation **68**. Further installations **70** can be provided as needed downslope from the installations **64** and **68** to similarly receive flows therefrom.

With reference to FIGS. 8A-C, an installation **74** of a plurality of devices **75** associated with a trail **76**, such as a walking path in a stream buffer or linear park is described in accordance with an embodiment of the invention. The devices **75** are identical to the device **10** but are provided with a different reference numeral for sake of clarity. As depicted in FIGS. 8A-C the trail **76** is disposed on, and perpendicular to an overall downward slope (depicted by an arrow **78**) of a surface **80**. During storm conditions the slope **78** forms an originating flow **82** that may be concentrated by features or characteristics of the surface **80** or may be generally broadly distributed along the surface **80** to intersect the trail **76** at discrete points or generally along its length, respectively.

The trail **76** is configured for vehicular and/or foot traffic, among other forms of traffic, e.g. equestrian. The trail **76** can be constructed with any desired form of traffic surface, such as asphalt, concrete, gravel, cinders, dirt, recycled rubber, wood, or the like. The trail **76** is constructed on a foundation or bed **84** formed by a plurality of the devices **75**. The bed **84** extends the entire length of the trail **76** or only portions thereof, such as only in areas of excess storm water or con-

centrated originating flow **82**. The bed **84** is comprised of a plurality of the devices **75** laid side-by-side and in one or more stacked layers which may be vertically aligned or offset. One or more of the devices **75** are exposed on an upslope side of the trail **76** to intercept the originating flow **82** before the flow **82** reaches the trail **76**. At least one device **75** is exposed along the downslope side of the trail **76** to enable type 2 overland flow to exit therefrom. The side-by-side placement of the devices **75** provides a continuous path through the devices **75** for the flow **82** from the upslope side, under the trail **76**, and out of the installation **74** onto the surface **80** or into the subsurface **44** on the downslope side of the trail **76**.

Although the devices are described as being exposed along the upslope or downslope sides of the installation, such is not intended to restrict embodiments of the invention to installations in which the devices **75** are visually exposed; the exposure described herein is to be understood as exposure to the originating flow **82** and to a downslope outlet therefor. For example, the upslope and downslope devices **75** might be overlain with one or more grates, particulate materials, or other objects or materials to provide a more aesthetic appearance.

A variety of design considerations might be considered in construction and placement of the installation **74**. For example, shallower slopes are generally known to produce slower, deeper flows, while steeper slopes produce faster, shallower flows. As such, the slope **78** is preferably sufficiently shallow to produce a flow rate of the originating flow **82** that is slow enough to allow infiltration of the flow **82** into the device **75** without excessive pooling on the upslope side of the installation **74**. The slope **78** is also preferably sufficiently steep to prevent the originating flow **82** from reaching a depth at which the originating flow **82** will overtop the installation **74**. However, in embodiments, the installation **74** can be constructed to provide for pooling of the flow **82** and to allow additional time for the flow **82** to infiltrate into the devices **75**.

Upon interception of the originating flow **82** by a first device **75a**, the flow **82** is dispersed within the intercepting device **75a** into type 1, type 2, or type 3 flows as described previously above. Type 1 flow from the first device **75a** is directed vertically downward into one or more underlying device **75b** and at least a portion thereof eventually infiltrates into the subsurface **44**. Type 2 flow from the first device **75a** is directed into one or more laterally adjacent devices **75c** located downslope therefrom. The type 1 and type 2 flows from the first device **75a** are similarly diverted through subsequent underlying and adjacent devices **75d** until reaching and infiltrating into the subsurface **44** as type 1 flow (shown by arrows **46**) or until reaching a final downslope device **75e** from which any remaining flow may exit as type 2 flow onto the surface **80** as overland flow or into the subsurface **44** as shown by arrows **48**.

Type 3 flow produced by the first device **75a** is directed parallel to the trail **76** until being sufficiently slowed to transform to type 1 or type 2 flow at which point it passes to the adjacent devices **75b** or **75c** as described above, or until exiting an end wall **18** of the device **75a** (not shown in FIGS. 8A-C). Accordingly, the originating flow **82** can be intercepted, slowed, and dispersed along the length of the trail **76** by the installation **74** to reduce the erosive power of the flow **82**. The installation **74** also aids to counteract deleterious effects caused by installing the trail **76** on the surface **80**. Diversion of the flow **82** beneath the trail **76** further resists erosion and undermining of the trail **76**, among other potential damage caused by the flow **82** of storm water.

Many different arrangements of the various components depicted, as well as components not shown, are possible

11

without departing from the scope of the claims below. Embodiments of the technology have been described with the intent to be illustrative rather than restrictive. Alternative embodiments will become apparent to readers of this disclosure after and because of reading it. Alternative means of implementing the aforementioned can be completed without departing from the scope of the claims below. Certain features and subcombinations are of utility and may be employed without reference to other features and subcombinations and are contemplated within the scope of the claims.

What is claimed is:

1. A storm-water redistribution device, comprising:
 - an elongate geotextile enclosure that includes a sidewall that forms a hollow interior space, the sidewall being configured to intercept a fluid flow that is directed substantially transverse to the direction of elongation of the enclosure, the fluid flow at least partially penetrating into the interior space through the sidewall to form an internal fluid flow;
 - a first partition forming a longitudinally extending, tubular section within the interior space;
 - a second partition disposed within the interior space and extending between opposing surfaces of the interior space and the first partition to divide the interior space into a plurality of sections; and
 - one or more particulate materials disposed in each of the sections, the particulate materials at least partially diverting the internal fluid flow in one or more directions including generally vertically downward, the generally vertically downward flow at least partially exiting through the sidewall as subsurface infiltration.
2. The storm-water redistribution device of claim 1, wherein the second partition is disposed in a plane that is generally transverse to the length of the enclosure and the sections comprise segments that are arranged end-to-end longitudinally along the length of the enclosure.
3. The storm-water redistribution device of claim 1, wherein the partition extends in a generally longitudinal plane extending along the length of the enclosure and the sections comprise compartments that are arranged side-by-side transversely across the width of the enclosure.
4. The storm-water redistribution device of claim 1, wherein adjacent sections are filled with one or more particulate materials having one or more of a different grade or different type to induce a desired flow characteristic within the respective section.
5. The storm-water redistribution device of claim 1, wherein the internal fluid flow is diverted into one or more of a flow directed substantially transversely to the length of the enclosure and a flow directed substantially longitudinally along the length of the enclosure, the flow directed transversely including one or more of a flow directed generally vertically downward toward and infiltrating into a subsurface and a flow directed generally horizontally and exiting the enclosure as overland flow, and the flow directed longitudinally moving through the partition from a first of the plurality of sections to a second of the plurality of sections.
6. The storm-water redistribution device of claim 1, wherein at least partially diverting the internal fluid flow by the one or more particulate materials produces headloss in the internal fluid flow.
7. The storm-water redistribution device of claim 1, wherein the geotextile enclosure at least partially filters the fluid flow.
8. The storm-water redistribution device of claim 1, wherein the geotextile enclosure comprises one or more of a mesh, a netting, a fabric, a perforated sheet, and a felt.

12

9. The storm-water redistribution device of claim 1, wherein the particulate materials comprise uniformly graded particles, well graded particles, or gap-graded particles.

10. The storm-water redistribution device of claim 1, wherein the one or more particulate materials in the respective sections are retained by the partition against movement of the particulate materials caused by interaction with the internal fluid flow and gravity.

11. The storm-water redistribution device of claim 1, wherein the partition is comprised of the same or a different material than the enclosure.

12. The storm-water redistribution device of claim 1, wherein a material comprising the partition and the particulate material disposed in the sections formed thereby are selected to provide a predetermined flow direction or a predetermined headloss.

13. A storm-water redistribution installation comprising:

an elongate storm-water redistribution device disposed on a surface having a slope, the device being positioned to extend substantially perpendicular to the slope and to receive an originating fluid flow along a sidewall of the device, the device including

the sidewall formed from a geotextile material that forms an enclosure with a hollow interior,

a first partition disposed in the interior to extend transversely across the interior to divide the interior into a plurality of sections arranged end-to-end along the length of the device,

a second partition forming a longitudinally extending, tubular section,

a third partition that extends between opposing surfaces of the interior of the enclosure and the second partition, and a particulate material disposed in one or more of the plurality of sections and retained against longitudinal movement within the device by the first partition, the device being configured to enable penetration of the originating fluid flow through the sidewall to form an internal fluid flow, a velocity of the internal fluid flow being reduced by contact of the internal fluid flow with the particulate material, and at least a portion of the internal fluid flow being directed generally vertically downward to exit through the sidewall as subsurface infiltration.

14. The storm-water redistribution installation of claim 13, further comprising a second device configured substantially similarly to the storm-water redistribution device and disposed alongside the storm-water redistribution device, the second device receiving a flow of fluid exiting the sidewall of the storm-water redistribution device.

15. The storm-water redistribution installation of claim 13, further comprising a second device configured substantially similarly to the storm-water redistribution device and disposed substantially perpendicular to and adjacent or abutting an end of the storm-water redistribution device and receiving a fluid flow exiting the end of the storm-water redistribution device.

16. The storm-water redistribution installation of claim 13, wherein the storm-water redistribution device is positioned downslope from an impervious structure and to receive a concentrated fluid flow from the impervious structure.

17. The storm-water redistribution installation of claim 13, wherein the storm-water redistribution device is disposed to extend in a substantially V-shaped orientation having an apex of the V-shape aligned with a source of the originating flow and first and second arms of the V-shape extending at least partially downslope.

13

18. A storm-water redistribution installation comprising:
 a bed formed from a plurality of elongate storm-water
 redistribution devices disposed side-by-side on a surface
 having a slope, the devices being positioned to extend
 substantially perpendicular to the slope and to receive an
 originating fluid flow along an upslope side of the bed,
 each of the devices including
 a sidewall formed from a geotextile material that forms an
 enclosure with a hollow interior,
 a partition disposed in the interior to divide the interior into
 a plurality of sections, and
 a particulate material disposed in one or more of the plu-
 rality of sections, the partition retaining a position of the
 particulate material relative to the device,
 each of the devices being configured to enable infiltration
 of a fluid flow through the sidewall to form an internal
 fluid flow, a velocity of the internal fluid flow being
 reduced by contact of the internal fluid flow with the
 particulate material; and

14

a traffic surface disposed to overlie at least a portion of the
 bed, the bed diverting the originating fluid flow longitu-
 dinally along the length of the bed and transversely
 beneath the traffic surface to at least partially exit the bed
 on a downslope side as one or more of overland or
 subsurface flow having a velocity less than that of the
 originating flow, wherein the traffic surface comprises a
 trail and the installation is located in one or more of a
 stream buffer and a linear park.

19. The storm-water redistribution installation of claim 18,
 wherein at least a portion of the fluid in the originating flow is
 diverted into a subsurface underlying the bed.

20. The storm-water redistribution device of claim 18,
 further comprising an inner partition forming a longitudinally
 extending, tubular section, and wherein the partition extends
 inward from the opposing surfaces of the interior space of the
 enclosure to respective opposing sides of the inner partition.

* * * * *